

WAR DEPARTMENT TECHNICAL MANUAL

TM 11-620

RADIO SETS

SCR-608-A AND SCR-628-A

WAR DEPARTMENT • 1 JANUARY 1944

War Department Technical Manual

TM 11-620

Radio Sets SCR-608-A and SCR-628-A

War Department

1 January 1944

WAR DEPARTMENT
WASHINGTON 25, D. C., 1 January, 1944.

TM 11-620, Radio Sets SCR-608-A and SCR-628-A, is published for the information and guidance of all concerned.

[A. G. 300.7 (6 August, 1943).]

By order of the Secretary of War:

G. C. MARSHALL,
Chief of Staff.

Official:

J. A. ULIO,
*Major General,
The Adjutant General.*

Distribution:

C and H6(4); Bn 18(4); IC18(2), 11(10).
(For explanation of symbols see FM 21-6.)

TABLE OF CONTENTS

SECTION I. Description.	<i>Page</i>
<i>Paragraph</i> 1. Purpose	1
2. Performance Characteristics	1
3. General Features	1
4. Associated Items	7
5. Frequency Modulation	9
6. Mounting FT-237-(*)	11
7. Radio Receiver BC-683-A	11
8. Radio Transmitter BC-684-A	12
9. Remote Control Unit RM-29-D	25
10. Dynamotors DM-34-(*), DM-35-(*), DM-36-(*), DM-37-(*)	25
11. Cabinet CH-74-A	27
12. Mountings FT-284-(*) and FT-285-(*) and Frame FM-43	27
13. Mast Bases	27
14. Mast Base Bracket MP-52	27
15. Mast Sections	27
16. Cords and Cordage	27
II. Installation and Operation.	
17. Initial Procedure	29
18. Installation	29
19. Preparation for Use	30
20. Operation	32
21. Presetting Push Buttons	36
22. System Operation	41
III. Functioning of Parts.	
23. Functioning of Radio Receiver BC-683-A	43
24. Functioning of Radio Transmitter BC-684-A	57
25. Functioning of Remote Control Unit RM-29-D	63
26. Functioning of Dynamotors DM-34-(*), DM-35-(*), DM-36-(*), DM-37-(*)	63
27. Functioning of Control Circuits	63
IV. Maintenance.	
28. General Maintenance Information	71
29. Routine Check of Mounting	73
30. Routine Check of Radio Receiver BC-683-A	73
31. Routine Check of Radio Transmitter BC-684-A	77
32. Routine Check of System	84
33. Emergency Check of Receiver Output Volume and Circuit Alignment	84
34. Emergency Alignment of Radio Receiver BC-683-A	86
35. Emergency Alignment of Radio Transmitter BC-684-A	95
36. Emergency Sources of Test Tones	100
37. Precision Alignment of Radio Receiver BC-683-A	100
38. Precision Alignment of Radio Transmitter BC-684-A	105
39. Location of Trouble in Radio Receiver BC-683-A	109
40. Location of Trouble in Radio Transmitter BC-684-A	124
41. Maintenance of Dynamotors	130
V. Supplementary Data.	
42. Replacement of Parts	133
43. Modifications During Manufacture	139
44. Color Codes on Components	149
45. Table of Replaceable Parts	156

LIST OF ILLUSTRATIONS

grouped according to components

Fig.	Title	Page
General:		
1	Radio Set SCR-608-A: Front View of Cabinet CH-74-A with Associated Components	VIII
2	Radio Set SCR-628-A: Front View of Cabinet CH-74-A with Associated Components	2
3	Radio Set SCR-608-A: Over-all and Unit Dimensions	8
23	Radio Set SCR-608-A: System Block Diagram	41
69	Radio Set SCR-608-A: System Schematic Diagram	189

Radio Receiver BC-683-A:

6	Front View	12
7	Oblique Rear View	13
8	Left-hand Interior View	14
9	Right-hand Interior View	15
10	Push-button Assembly, Right-side View	16
11	Push-button Assembly, Front View	16
24	Block Diagram	43
25	Functional Diagram of R-f Amplifier, Modulator, and R-f Oscillator	44
26	Functional Diagram of I-f Amplifier and Limiter	46
27a	Functional Diagram of Discriminator	48
27b, c, d	Vector Diagrams Showing Phase Relations in the Discriminator	49
28	Functional Diagram of A-f Amplifier	51
29	Functional Diagram of Delayed-automatic-volume-control Circuit	52
30	Functional Diagram of Squelch Circuit	54
31	Functional Diagram of I-f Oscillator	56
32	Functional Diagram of the Heater Circuits	57
43	Wiring Diagram of Front Panel	72
44	Apparatus Location Diagram, Front View of Panel	73
45	Apparatus Location Diagram, Left-side View	74
46	Apparatus Location Diagram, Right-side View	75
51	Location of Alignment and Tuning Controls	93
57	Voltage Diagram	117
58	Resistance Diagram	119
70	Schematic Diagram Showing Modifications During Manufacture	191
71	Schematic Diagram	193
72	Wiring Diagram Without Front Panel	195

Radio Transmitter BC-684-A:

12	Front View With Crystal Compartment Open	17
13	Assembly and Exploded View of Crystals	18
14	Right-hand End View with Cover Plate Removed	19
15	Interior View with Top Cover and Dynamotor Removed	20
16	Push-button Assembly, Left-side View	21
17	Push-button Assembly, Right-side View	21
18	Interior View with Bottom Cover Removed	22
33	Block Diagram	58
34	Functional Diagram of Oscillator and First R-f Amplifier	58
35	Functional Diagram of Modulator and Rectifier	59
36	Method of Modulation	60
37	Functional Diagram of Tripler, Doubler, Power Amplifier, and Antenna Coupling Circuits	61
38	Functional Diagram of A-f Amplifier	62
47	Apparatus Location Diagram, End View and Detail Through Section A-A	78
48	Apparatus Location Diagram, Top View	79

LIST OF ILLUSTRATIONS—Continued

Fig.	Title	Page
49	Apparatus Location Diagram, Front View	80
50	Apparatus Location Diagram, Bottom View	82
52	Location of Alignment and Tuning Controls	97
59	Voltage Diagram	125
60	Resistance Diagram	127
73	Schematic Diagram Showing Modifications During Manufacture	197
74	Schematic Diagram	199
75	Wiring Diagram	201
77	Artificial Antenna Used for Testing	205

Mounting FT-237-():*

4	Oblique Front View	10
5	Details	10
61	Schematic Diagram	133
62	Wiring Diagram	135

Remote Control Unit RM-29-D:

19	Front View	23
20	Interior View	23
76	Schematic and Wiring Diagram	203

Dynamotors DM-34-(), DM-35-(*), DM-36-(*), DM-37-(*):*

21a	Dynamotor DM-34-(*) or Dynamotor DM-36-(*)	24
21b	Dynamotor DM-34-(*) or Dynamotor DM-36-(*) : Sub-base View	24
22a	Dynamotor DM-35-(*) or Dynamotor DM-37-(*)	26
22b	Dynamotor DM-35-(*) or Dynamotor DM-37-(*) : Sub-base View	26
39	Schematic and Wiring Diagrams	64-65
40	Apparatus Location Diagrams	66
41	Dynamotor DM-34-(*) or Dynamotor DM-36-(*) : Exploded View	67
42	Dynamotor DM-35-(*) or Dynamotor DM-37-(*) : Exploded View	68

Adapter FT-384-():*

53	Front View	101
54	Back View	101
55	Application to Radio Receiver BC-683-A	102
56	Schematic and Wiring Diagram	103

Capacitors and Resistors:

63	Types of Capacitors and Resistors	146
64	Molded Mica Capacitors: Three-dot Color Code	150
65	Molded Mica Capacitors: RMA Six-dot Color Code	151
66a	Molded Mica Capacitors: AWS Six-dot Color Code	152
66b	Molded Paper Capacitors: AWS Six-dot Color Code	153
67	Tubular Ceramic Capacitors: RMA Color Code	153
68	Fixed Resistors: RMA and AWS Color Codes	154

Artificial Antenna:

77	For Testing Radio Transmitter BC-684-A	205
----	--	-----

LIST OF TABLES AND CHARTS

<i>Table</i>	<i>Title</i>	<i>Page</i>
I	List of Components and Other Items Required	3
II	Channel and Crystal Frequencies	6
III	Battery Currents	9
IV	Selection of Dynamotors	29
V	Meter Switch Readings (RECEIVER TUNE-OPERATE switch at OPERATE)	32
VI	Meter Switch Readings (RECEIVER TUNE-OPERATE switch at RECEIVER TUNE)	129
VII	Capacitor Characteristics	147
VIII	Table of Replaceable Parts	156
IX	List of Manufacturers	187

Chart

I	Equipment Required for Servicing of Radio Receiver BC-683-A	121
II	Servicing Procedure for Radio Receivers BC-683-A Not Mounted in a Vehicle	122
III	Servicing Procedure for Radio Receivers BC-683-A Mounted in a Vehicle	123

DESTRUCTION NOTICE

WHY To prevent the enemy from using or salvaging this equipment for his benefit.

WHEN When ordered by your commander, or when you are in immediate danger of capture.

- HOW**
1. Smash— Use sledges, axes, hand-axes, pick axes, hammers, crowbars, heavy tools, etc.
 2. Cut— Use axes, hand-axes, machete, etc.
 3. Burn— Use gasoline, kerosene, oil, flame-throwers, incendiary grenades, etc.
 4. Explosives— Use firearms, grenades, TNT, etc.
 5. Disposal— Bury in slit trenches, foxholes, other holes. Throw in streams. Scatter.
 6. *Use anything immediately available for destruction of this equipment.*

- WHAT**
1. Smash— Crystals, meter, plugs, tuning controls, tubes, capacitors, resistors, sockets, insulators, microphones, headsets, and relays.
 2. Cut— Cords, wiring, and cables.
 3. Bend and/or Break— Antenna sections, panels, mounting, and nameplate.
 4. Burn— Circuit label, technical manual and all papers, cords, wiring, cable, dynamotors, capacitors, resistors, and nameplate.
 5. Bury and/or Scatter— Any or all of the above pieces after breaking.

DESTROY EVERYTHING

SAFETY NOTICE

THIS EQUIPMENT USES DANGEROUSLY HIGH VOLTAGES. IT CAN KICK LIKE A MULE AND IS A DARN SIGHT MORE DANGEROUS. DON'T CHANGE VACUUM TUBES OR WORK IN THE EQUIPMENT WITH THE DYNAMOTOR RUNNING, EXCEPT AS SPECIFICALLY DIRECTED IN THIS MANUAL. BE CAREFUL, DON'T TAKE CHANCES.

SPECIAL NOTICE

Certain schematic and wiring diagrams in this manual include modifications during manufacture which are discussed in Paragraph 43. Not all these changes are included in the functional diagrams, Figs. 25 through 38. Any discrepancies between these two groups of figures are explained under appropriate heading in Paragraph 43. In case of such discrepancies, follow the circuit label on the equipment.

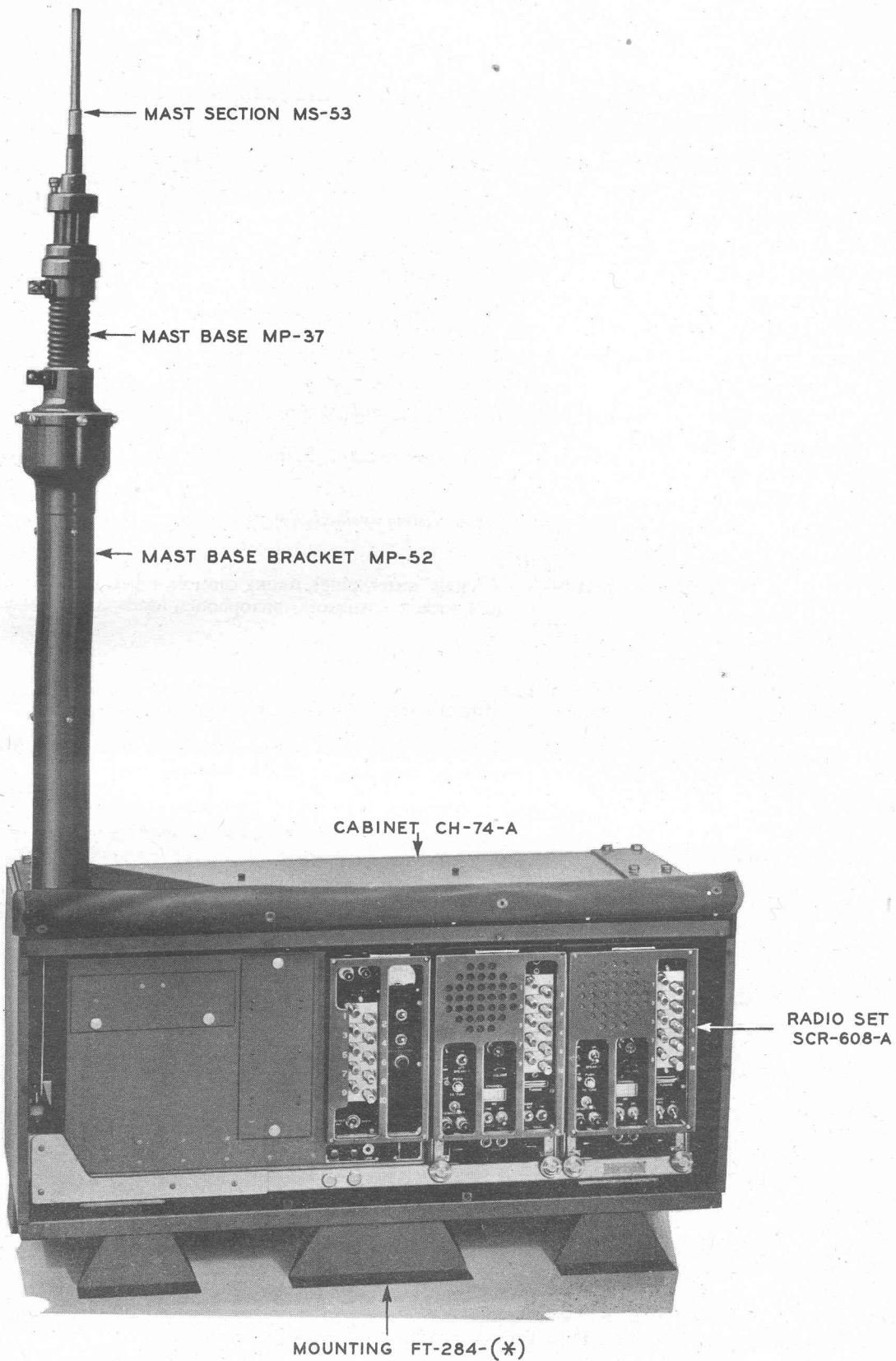

Fig. 1. Radio Set SCR-608-A: Front View of Cabinet CH-74-A with Associated Components

SECTION I. DESCRIPTION

1. **Purpose.** Radio Sets SCR-608-A and SCR-628-A provide frequency-modulated radio telephone communication for anti-aircraft and anti-tank warning and control nets, for base stations at battalion command posts for fire control and fire direction nets, and for intra-battalion communication. The radio sets may be installed and operated in combat vehicles such as command cars, half-tracks, or any other authorized vehicle.

The sets are designed to operate within a temperature range of minus 40 degrees to plus 130 degrees Fahrenheit around the set. Don't operate this equipment for long periods of time in enclosed spaces where the temperature may rise too high. Watch this.

2. **Performance Characteristics.**

a. *System.*

- (1) Frequency range.....27.0 to 38.9 megacycles
- (2) Channel spacing.....100 kilocycles
- (3) Number of channels available.....120
- (4) Channel numbers.....270 to 389 inclusive
- (5) Number of preset channels.....10
- (6) Communication range.....5 to 15 miles
- (7) Power supply.....12- or 24-volt vehicular battery (see Note)

Note: Radio Sets SCR-608-A and SCR-628-A are equipped with dynamotors for operation from a 12-volt battery. If authorized, they may be operated from a 24-volt battery by substitution of the proper dynamotor. This is explained fully in Paragraph 10c. Be sure you don't operate your set from a battery of the wrong voltage. You'll burn out tubes, dynamotor, and capacitors.

b. *Radio Receiver BC-683-A.*

- (1) Sensitivity 1 microvolt
- (2) Intermediate frequency.....2.65 megacycles
- (3) Band width80 kilocycles
- (4) Power output, speaker.....2 watts
- (5) Power output, headset.....0.2 watt
- (6) Call signalLamp
- (7) Noise suppression“Squelch”
- (8) Battery drain, 12-volt supply.....4 amperes
- (9) Battery drain, 24-volt supply.....2 amperes (see Note under Paragraph 2a.)

NOTE: Throughout this manual an asterisk within parentheses (*) indicates the applicable issue letter of interchangeable components of the equipment.

c. *Radio Transmitter BC-684-A.*

- (1) Nominal power output.....20 watts
- (2) Nominal frequency deviation± 40 kilocycles
- (3) Crystal frequency range.....375.000 to 540.277 kilocycles
- (4) Frequency multiplication72
- (5) Battery drain, 12-volt supply.....20 amperes
- (6) Battery drain, 24-volt supply12 amperes (see Note under Paragraph 2a.)

3. **General Features.**

a. *Arrangement and Weight of Major Components.* The general construction and arrangement of Radio Sets SCR-608-A and SCR-628-A are shown in Figs. 1 and 2. Over-all component and assembly dimensions are shown in Fig. 3. The radio sets consist of these combinations of major units:

(1) *Radio Set SCR-608-A.*

- 2 Radio Receivers BC-683-A with 12-volt Dynamotor DM-34-(*).....70 lbs.
- 1 Radio Transmitter BC-684-A with 12-volt Dynamotor DM-35-(*).....67 lbs.
- 1 Mounting FT-237-(*) with Cord CO-278-A for connection to power supply44 lbs.
- Total weight.....181 lbs.

(2) *Radio Set SCR-628-A.*

- 1 Radio Receiver BC-683-A with 12-volt Dynamotor DM-34-(*).....35 lbs.
- 1 Radio Transmitter BC-684-A with 12-volt Dynamotor DM-35-(*).....67 lbs.
- 1 Mounting FT-237-(*) with Cord CO-278-A for connection to power supply44 lbs.
- Total weight.....146 lbs.

b. *Components of Radio Sets SCR-608-A and SCR-628-A.* For a list of components, refer to Table I.

c. *Vacuum Tube Complement.* Radio Receiver BC-683-A and Radio Transmitter BC-684-A include, and are issued with, a complete

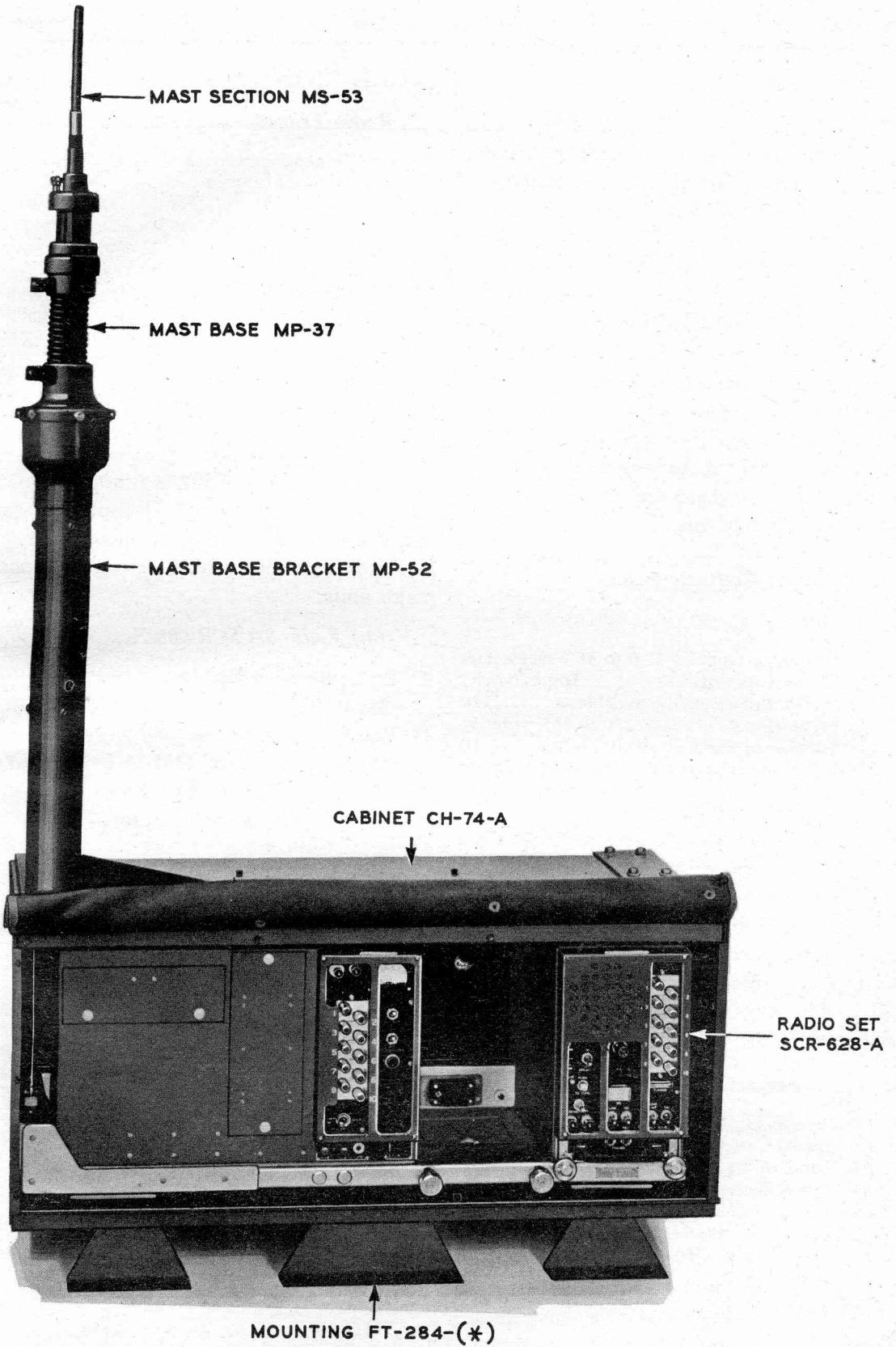

Fig. 2. Radio Set SCR-628-A: Front View of Cabinet CH-74-A with Associated Components

Table I. List of Components and Other Items Required

<i>Quantity</i>	<i>Article</i>
	Adapter Kit MC-471; includes:
*	1 Adapter plate; 15 in. x 35 in. x 1 $\frac{3}{8}$ in.
	1 Reinforced plate; 16 in. x 1 $\frac{1}{2}$ in. x $\frac{3}{16}$ in.
	Necessary hardware
1	Antenna A-83-(*) (Phantom)
2	Battery Bracket BA-27 [for Remote Control Unit RM-29-(*)]; 1 in Use, 1 Running Spare
1	Box BX-40 [for 30 crystal Holders FT-241-(*)]; includes 30 Holders FT-241-(*)
*	Bracket (extension for Mounting FT-285)
*	Bracket (Cabinet CH-74-A)
*	Cabinet CH-74-A
1	Case CS-76-(*) [for Remote Control Unit RM-29-(*)]
1	Chest CH-96 [for Microphone T-17, Headset HS-30-(*), Box BX-40, spare tubes, technical manuals, etc.]
2	Clamp MC-423 (for Mast Section MS-51); 1 in Use, 1 Running Spare
2	Clamp MC-424 (for Mast Section MS-52); 1 in Use, 1 Running Spare
2	Cord CD-307-A [65-in. long, for Headset HS-30-(*)]; 1 in Use, 1 Running Spare
*	Connector and Bondnut; Appleton Electric Co. No. 61004 and BL-50 respectively
*	Connector and Bondnut; Appleton Electric Co. No. 61007 and BL-50 respectively
2	Cord CD-604 [for Headset HS-30-(*)]; 1 in Use, 1 Running Spare
1	Cord CD-689 (for Mast Base MP-48-A)
*	Cable WC-562
*	Cord CD-318-A (for Microphone T-45)
*	Cordage CO-212
*	Cordage CO-218 [for connecting slip ring to Interphone Control Box BC-606-(*) in turret.]
1	Cover BG-96 (for radio set)
1	Cover BG-108 (for Mast Base MP-48-A)
2	Dynamotor DM-34-(*) [for Radio Receiver BC-683-(*)]; 12 volts; includes the following Running Spare in BAG attached to dynamotor: 4-BRUSH (L.V.) INCLUDES SPRINGS 4-BRUSH (H.V.) INCLUDES SPRINGS
1	Dynamotor DM-35-(*) [for Radio Transmitter BC-684-(*)]; 12 volts; includes the following Running Spare in BAG attached to dynamotor: 4-BRUSH (L.V.) INCLUDES SPRING 4-BRUSH (H.V.) INCLUDES SPRING
1	Frame FM-43 [for Cabinet CH-74-A or Mounting FT-237-(*)]
1	Hardware Kit: Miscellaneous items
2	Headset HS-30-(*); 1 in Use, 1 Running Spare (When Headset HS-30-(*) is not available, Headset HS-18 or HS-23 may be issued.)
*	Insulator IN-101
*	Insulator IN-104
*	Insulator IN-121 (1 $\frac{1}{8}$ -in. long, for insulating antenna wire through metal partition.)
*	Interphone Control Box BC-606-(*); includes attached hardware as follows: screws, washers, clamps, clips, and hooks.

Table I. List of Components and Other Items Required—*Continued*

<i>Quantity</i>	<i>Article</i>
1	Mast Base MP-48-A
*	Mast Base Bracket MP-52 (Cabinet CH-74-A)
*	Mast Base Bracket MP-54
*	Mast Section MS-51
2	Mast Section MS-52; 1 in Use, 1 Running Spare
2	Mast Section MS-53; 1 in Use, 1 Running Spare
*	Microphone T-17 (hand-type)
*	Microphone T-45 (lip-type) (When Microphone T-17 or T-45 is not available, Microphone T-30 may be issued.)
3	Microphone Cover M-367; 2 in Use, 1 Running Spare
1	Mounting FT-237-(*); includes: 1 Cord CO-278 (for power) 1 set dust covers for receptacles All necessary mounting bolts, nuts, and lock washers.
*	Mounting FT-284 (for Cabinet CH-74-A)
*	Mounting FT-285 (for Cabinet CH-74-A); includes: mounting bolts, nuts, screws, straps, and bracket.
*	Mounting FT-326
2	Radio Receiver BC-683-(*); includes: 10 Fuse FU-24; 1 in Use, 9 Running Spare 3 Lamp LM-63; 1 in Use, 2 Running Spare 2 Tube JAN-6H6 (VT-90); 1 in Use, 1 Running Spare 2 Tube JAN-6J5 (VT-94); 1 in Use, 1 Running Spare 2 Tube JAN-6V6GT/G (VT-107-A); 1 in Use, 1 Running Spare 4 Tube JAN-6AC7/1852 (VT-112); 3 in Use, 1 Running Spare 3 Tube JAN-12SG7 (VT-209); 2 in Use, 1 Running Spare 3 Tube JAN-6SL7GT (VT-229); 2 in Use, 1 Running Spare
1	Radio Transmitter BC-684-(*); includes: 120 Crystal Holder FT-241-(*), with Crystal (10 in Sockets, 80 in Drawer Compartment, 30 in Box BX-40) 10 Fuse FU-64; 1 in Use, 9 Running Spare 3 Lamp LM-38; 1 in Use, 2 Running Spare 11 Tube JAN-1619 (VT-164); 7 in Use, 4 Running Spare 2 Tube JAN-1624 (VT-165); 1 in Use, 1 Running Spare
1	Remote Control Unit RM-29-(*)
1	Roll BG-56-A (for antenna mast sections)
2	Technical Manual TM 11-620 for Radio Sets SCR-608-(*), and SCR-628-(*)
6 ft.	Wire W-128

The asterisk within parentheses (*) indicates that items so indicated are interchangeable with those marked with a different suffix letter.

An asterisk in the column headed *Quantity* indicates that the item is issued in quantities authorized, depending upon the type of installation to be made.

set of vacuum tubes in place. The tube complement of each component follows:

(1) *Radio Receiver BC-683-A.*

Circuit Designation	Function	Signal Corps Designation	Commercial Designation
V1	R-f amplifier	VT-112	6AC7
V2	Modulator	VT-112	6AC7
V3	R-f oscillator	VT-94	6J5
V4	I-f amplifier	VT-209	12SG7
V5	I-f amplifier	VT-209	12SG7
V6	Limiter	VT-112	6AC7
V7	Detector (discriminator)	VT-90	6H6
V8	Second a-f amplifier	VT-107-A	6V6-GT
V9	AVC and squelch	VT-229	6SL7-GT
V10	First a-f amplifier and i-f oscillator	VT-229	6SL7-GT

(2) *Radio Transmitter BC-684-A.*

Circuit Designation	Function	Signal Corps Designation	Commercial Designation
V101	First r-f amplifier	VT-164	1619
V102	Rectifier	VT-164	1619
V103	Doubler	VT-164	1619
V104	Power amplifier	VT-165	1624
V105	First a-f amplifier	VT-164	1619
V106	Second a-f amplifier	VT-164	1619
V107	Oscillator	VT-164	1619
V108	Tripler	VT-164	1619

d. Crystal Holders and Frequency Range.

The receiver and transmitter operate between 27.0 and 38.9 megacycles; this range is divided into 120 channels of 100 kilocycles each. (See Table II.) Channels 270 to 279, inclusive, have the same frequencies as channels 70 to 79, inclusive, of the Armored Force [Radio Sets SCR-508-(*), SCR-528-(*), and SCR-538-(*)]. These channels may therefore be used for liaison purposes.

A drawer in the transmitter provides storage for 80 Crystal Holders FT-241-A, one for each of 80 channel frequencies out of the 120 channels available. Each crystal holder contains a low-frequency quartz crystal (see Table II), and is marked with the channel number and output frequency.

e. General Spare Equipment.

(1) *Receiver.* Ten 15-ampere Fuses FU-24 (one in use, one in the spare holder, and eight in the attached bag) and three neon CALL SIGNAL lamps (one in use and two in the attached bag) are furnished with each receiver.

(2) *Transmitter.* Ten 1/2-ampere Littelfuse Type 4AG fuses (one installed, one in the spare holder, and eight in the attached bag) and three pilot lamps (one installed and two in the attached bag) are furnished with each transmitter.

(3) *Mounting.* The mounting includes and is issued with one Cord CO-278-A and ten 75-ampere Western Electric 66B fuses (one in use, one in the spare holder, and eight in the attached bag). Also included are one set of receptacle dust covers and all necessary mounting bolts, nuts, and lock washers, together with two copies of Preliminary Instructions for Radio Sets SCR-608-A and SCR-628-A.

f. Code Designation of Component Parts.

Remember the method of numbering the component parts used in the various units of these radio sets. This will help you determine whether the part belongs in the receiver, transmitter, etc. Parts in the schematic and wiring diagrams, and usually on the equipment units also, are designated by a number preceded by one or more letters. For example, C25, C115, L701, etc. Numbers for these units are shown in the column headed "Reference Number" in the Table of Replaceable Parts, Paragraph 45. Reference numbers from:

- 1 to 99 are used for parts in Radio Receiver BC-683-A.
- 101 to 199 are used for parts in Radio Transmitter BC-684-A.
- 401 to 499 are used for parts in Mounting FT-237-(*).
- 501 to 599 are used for parts in Dynamotor DM-35-(*). (transmitter, 12 volts).
- 601 to 699 are used for parts in Dynamotor DM-37-(*). (transmitter, 24 volts).
- 701 to 799 are used for parts in Dynamotor DM-34-(*). (receiver, 12 volts).
- 801 to 899 are used for parts in Dynamotor DM-36-(*). (receiver, 24 volts).

Table II. Channel and Crystal Frequencies

<u>Channel</u>	<u>Crystal Frequency (kilocycles)</u>	<u>Output Frequency (megacycles)</u>	<u>Channel</u>	<u>Crystal Frequency (kilocycles)</u>	<u>Output Frequency (megacycles)</u>
270	375.000	27.0	330	458.333	33.0
271	376.388	27.1	331	459.722	33.1
272	377.777	27.2	332	461.111	33.2
273	379.166	27.3	333	462.500	33.3
274	380.555	27.4	334	463.888	33.4
275	381.944	27.5	335	465.277	33.5
276	383.333	27.6	336	466.666	33.6
277	384.722	27.7	337	468.055	33.7
278	386.111	27.8	338	469.444	33.8
279	387.500	27.9	339	470.833	33.9
280	388.888	28.0	340	472.222	34.0
281	390.277	28.1	341	473.611	34.1
282	391.666	28.2	342	475.000	34.2
283	393.055	28.3	343	476.388	34.3
284	394.444	28.4	344	477.777	34.4
285	395.833	28.5	345	479.166	34.5
286	397.222	28.6	346	480.555	34.6
287	398.611	28.7	347	481.944	34.7
288	400.000	28.8	348	483.333	34.8
289	401.388	28.9	349	484.722	34.9
290	402.777	29.0	350	486.111	35.0
291	404.166	29.1	351	487.500	35.1
292	405.555	29.2	352	488.888	35.2
293	406.944	29.3	353	490.277	35.3
294	408.333	29.4	354	491.666	35.4
295	409.722	29.5	355	493.055	35.5
296	411.111	29.6	356	494.444	35.6
297	412.500	29.7	357	495.833	35.7
298	413.888	29.8	358	497.222	35.8
299	415.277	29.9	359	498.611	35.9
300	416.666	30.0	360	500.000	36.0
301	418.055	30.1	361	501.388	36.1
302	419.444	30.2	362	502.777	36.2
303	420.833	30.3	363	504.166	36.3
304	422.222	30.4	364	505.555	36.4
305	423.611	30.5	365	506.944	36.5
306	425.000	30.6	366	508.333	36.6
307	426.388	30.7	367	509.722	36.7
308	427.777	30.8	368	511.111	36.8
309	429.166	30.9	369	512.500	36.9
310	430.555	31.0	370	513.888	37.0
311	431.944	31.1	371	515.277	37.1
312	433.333	31.2	372	516.666	37.2
313	434.722	31.3	373	518.055	37.3
314	436.111	31.4	374	519.444	37.4
315	437.500	31.5	375	520.833	37.5
316	438.888	31.6	376	522.222	37.6
317	440.277	31.7	377	523.611	37.7
318	441.666	31.8	378	525.000	37.8
319	443.055	31.9	379	526.388	37.9
320	444.444	32.0	380	527.777	38.0
321	445.833	32.1	381	529.166	38.1
322	447.222	32.2	382	530.555	38.2
323	448.611	32.3	383	531.944	38.3
324	450.000	32.4	384	533.333	38.4
325	451.388	32.5	385	534.722	38.5
326	452.777	32.6	386	536.111	38.6
327	454.166	32.7	387	537.500	38.7
328	455.555	32.8	388	538.888	38.8
329	456.944	32.9	389	540.277	38.9

4. Associated Items.

a. Antenna System.

(1) Mast Base MP-48 or MP-37 is used and *must be mounted in such a way that the antenna will normally be in a vertical position.* Mast Base MP-48 is equipped with a coaxial connector cable running up through the center. An antenna terminal is provided at the top of the mast base. Another terminal is provided on the lower end of the coaxial connector cable for connecting to the set by means of Wire W-128. A coaxial cable fitting is also furnished with MP-48 for the purpose of joining the lower end of the coaxial connector cable of MP-48 to a coaxial line from the set.

(2) Three mast sections (MS-51, MS-52, MS-53) must be used, except that only two mast sections (MS-52, MS-53) are to be used with Mast Base Bracket MP-52. (Mast Base Bracket MP-52 is used in half-track installations and is mounted on the top of Cabinet CH-74-A at the left front corner.) Mast joints should be tightened securely by use of gas pliers or other suitable tools, and should be taped to prevent loss of mast sections. Put on two servings of friction tape as tightly as possible. The first serving should be applied counterclockwise, starting on the lower half of the joint and taping upwards from the left to the right. If available, Clamps MC-423 and MC-424 should be used instead of tape.

(3) Wire W-128 should be used between the mast base and the set when the length of the run is less than 40 inches. Do not use more W-128 than is necessary. This wire can be connected to either the top or the bottom terminal of MP-48, or may be fed up through the center of MP-48 after removal of the center coaxial connector cable. In the latter case the maximum permissible length of W-128 is 52 inches. *The center coaxial cable must always be removed when connection is made to the top terminal; otherwise the range of the set will be reduced greatly.* When passing W-128 through the side of the vehicle, chests, etc., always insert an insulating bushing, such as IN-101 or IN-111, in the

hole to protect the wire. Wire should be run and supported in such a way that it is protected from damage and will not be subject to chafing due to vibration.

(4) Coaxial cable, Cordage CO-282, should be used between the mast base and the set when the length of run is over 40 inches. The length of CO-282 must *always* be 7 feet (plus or minus 1 foot). If 7 feet is more than is needed, tape up the excess in a coil. The sheath of CO-282 *must* be grounded at *both* ends. When MP-37 is used, a short ground lead at the mast base is required to ground the sheath. When MP-48 is used, the coaxial cable fitting that joins CO-282 to the center coaxial cable connector of MP-48 provides for sheath grounding at the mast base. When passing CO-282 through the side of the vehicle, chests, etc., always insert an insulating bushing, such as IN-101 or IN-111, in the hole. Cable should be run and supported in such a way that it is protected from damage and will not be subject to chafing due to vibration.

(5) In installations using Mast Base Bracket MP-52 mounted on top of Cabinet CH-74-A, the lead from the mast base to the binding post on Mounting FT-237-(*) will be W-128 run inside of MP-52. Coaxial cable must not be used and will be removed from MP-48, if already installed.

(6) The antenna may be tied down when the vehicle is in motion in order to clear overhead power lines and obstructions. When the vehicle is stationary, the antenna may be tied down for reasons of concealment. Remember, however, that *range and signal strength are reduced* when the antenna is tied down. For maximum range and signal strength release the antenna. The antenna may be tied down by the use of Rope RP-5, an insulator such as IN-86 or IN-87, and a short piece of flat metal. Drill holes in each end of the metal piece, slip it over the threaded part of a mast section ferrule, and assemble the joint. Tie down to a convenient point on the vehicle with the insulator placed close to the antenna mast.

Note: The radiating system, which includes the antenna and ground circuit, must be of such

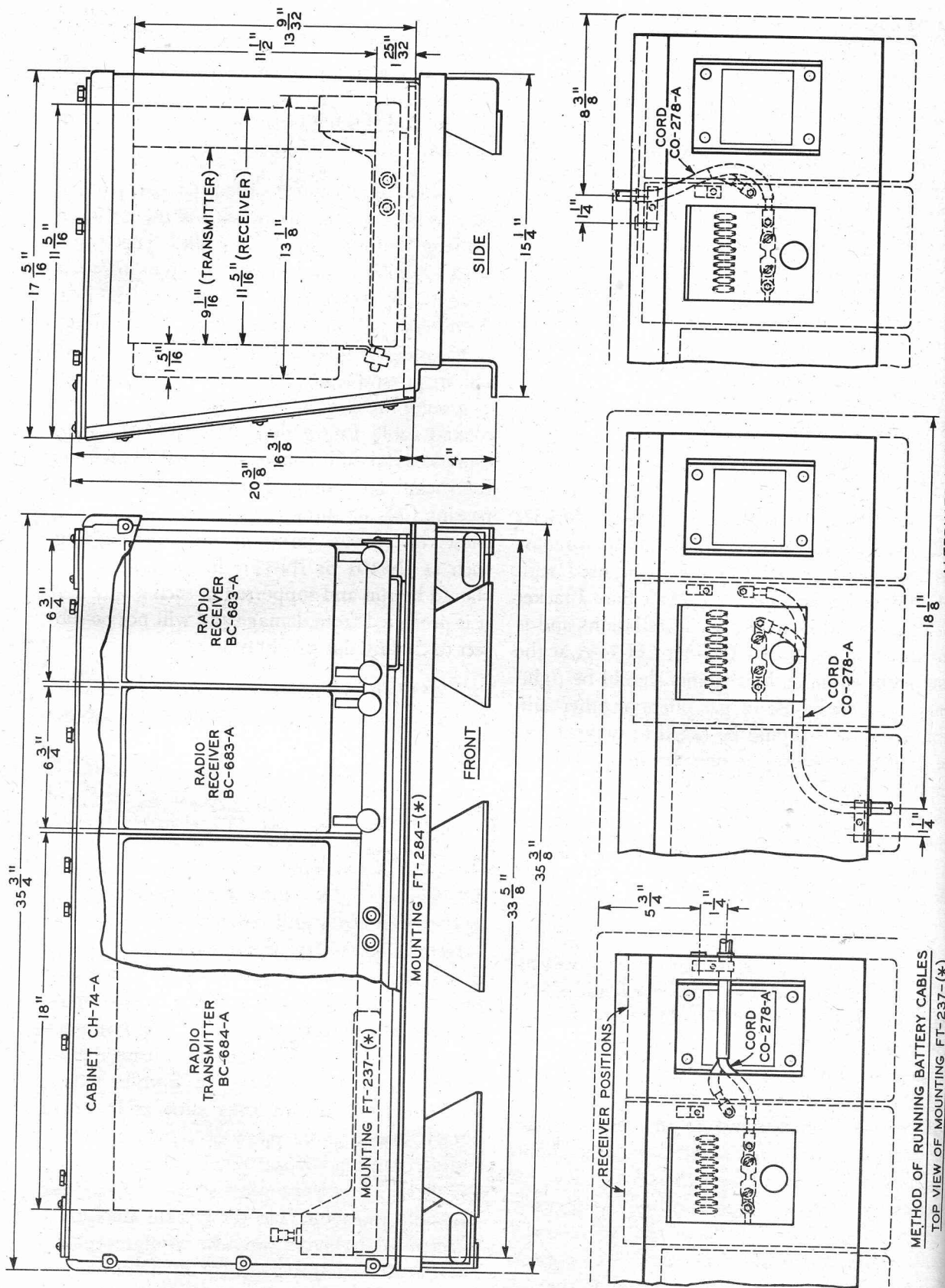

Fig. 3. Radio Set SCR-608-A: Over-all and Unit Dimensions

dimensions that the circuits of the transmitter and the receiver can be resonated at the authorized frequencies. Make the ground connection for the antenna system through the contact between the mounting and the frame of the vehicle. Where there is no direct connection to the frame, or where the connection is unsuitable, connect it to the frame through short lengths of braided copper strap 1/2-inch wide. Make certain that there is good electrical contact at both ends of the straps and allow sufficient slack to permit free movement of the unit in the shock mounting. If your ground lead is too short, vibration will soon break it.

b. Microphones and Headsets. One Headset HS-30-(*), HS-18, or HS-23 and one Microphone T-17, T-30, or T-33 are required for each person using the equipment. Microphone T-17 is the carbon hand type, Microphone T-30 is the carbon throat type, and Microphone T-33 is the magnetic hand type. Separate jacks are provided for use with either the carbon or the magnetic type of microphone.

c. Battery Power Supply. Your radio sets operate from either a 12- or 24-volt battery power source (depending upon the transmitter and receiver dynamotors furnished; see Paragraph 10). The battery used is the one already installed in your vehicle. *You must have sufficient battery capacity and charging rate to maintain essentially full charge in the battery under all operating conditions.* The battery current required to operate all units of the radio sets is given in Table III. Keep it in mind. Don't let your battery become discharged. If it does your communications will fail and your vehicle stall.

Table III. Battery Currents

Radio Set	Battery Drain (Amperes)	
	12-Volt Battery (11-15 volts)	24-Volt Battery (22-30 volts)
SCR-608-A	28	16
SCR-628-A	24	14

5. Frequency Modulation.

a. Radio Sets SCR-608-A and SCR-628-A operate on the principle of frequency modulation.

This system of communication, which is comparatively new, has one important advantage over the older amplitude modulation systems: Within the limit of its useful range, trouble from static is greatly reduced. Of course, static is not completely eliminated, but *within* the normal 5- to 15-mile range it is much less troublesome. If static becomes strong when talking to another station, it is generally a sign that you are near the limit of your working range. (See Paragraph 20d for good and bad places for radio communication.) Some of the technical features of frequency modulation (FM) are explained in Section III of this manual. The basic idea is outlined briefly in the following paragraphs.

b. Communication is effected by modulation of the carrier frequency. That is to say, *the carrier frequency is made to vary with the loudness and pitch of the voice signal. Loud speech causes greater variation of the carrier frequency, soft speech causes less variation. High-pitched sounds cause the carrier frequency to vary more rapidly than do low-pitched sounds. The amplitude and power of the transmitted wave remain substantially constant during modulation.*

These characteristics are quite different from those of amplitude modulation such as used by Radio Sets SCR-245-(*), and SCR-299-(*), in which the *amplitude and modulating frequency* of the transmitted wave vary with the speech *loudness and pitch*, while the carrier frequency remains constant. Static noise is more closely related to *amplitude modulation* than it is to *frequency modulation*; therefore interference with signals is reduced through the use of frequency-modulation receiver circuits which suppress amplitude variations. This "*discrimination*" against received static noise gives you improved communication within your set's range. But at the *end* of your range and *beyond it*, frequency modulation cannot control static. Therefore, when static gets bad, you're either at the end of your range, or your receiver isn't getting much of a signal from the station you are trying to hear.

The methods employed for modulation and demodulation are explained in Paragraphs 23 and 24 of this technical manual.

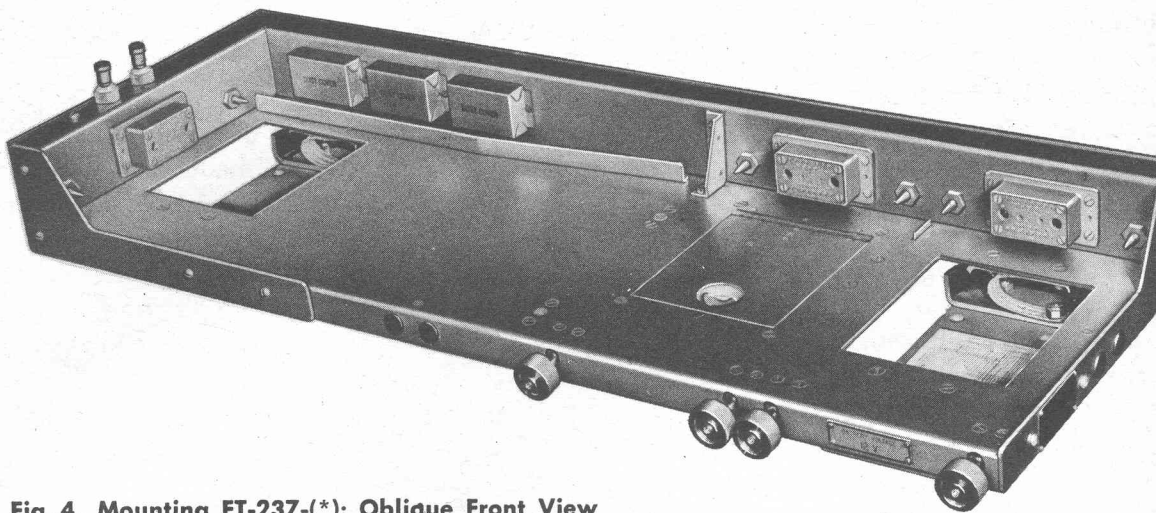

Fig. 4. Mounting FT-237-(*): Oblique Front View

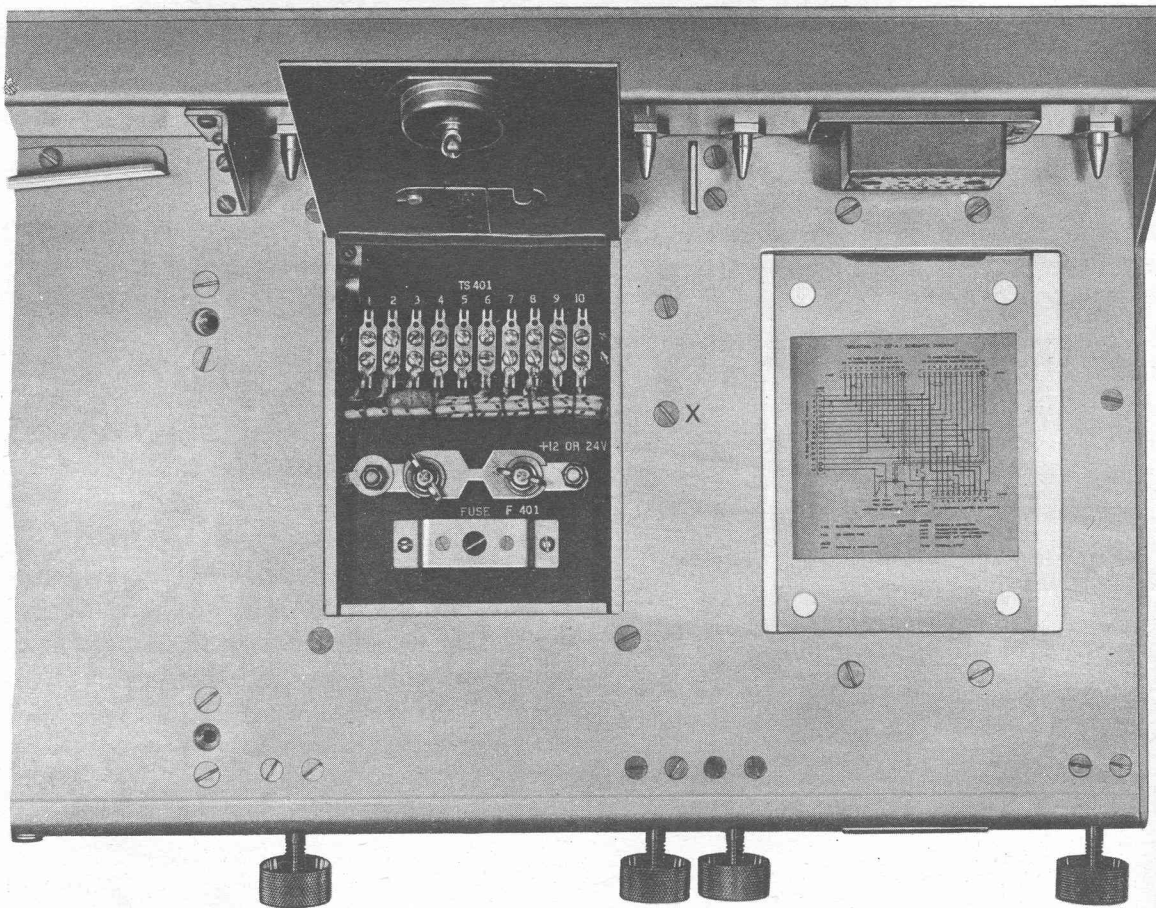

Fig. 5. Mounting FT-237-(*): Details

6. Mounting FT-237-(*).

a. General. This mounting (Fig. 4), will hold either:

(1) Radio Set SCR-608-A. One Radio Transmitter BC-684-A and two Radio Receivers BC-683-A.

(2) Radio Set SCR-628-A. One Radio Transmitter BC-684-A and one Radio Receiver BC-683-A.

The transmitter must be installed in its allotted place at the left end of the mounting, but the receiver may be installed in either of the two right-hand positions. Each unit is secured to the mounting by thumbscrew clamps and may be quickly removed without tools.

Dust covers are provided for protection of the unused receptacles. Screw the dust covers to the rear of the mounting when removed from the receptacles. (See Fig. 4.)

A reversible nameplate bearing the words BATTERY VOLTAGE 12 V on one side, and BATTERY VOLTAGE 24 V on the other side, is screwed to the front of the mounting near the right-hand end. (This plate will normally show BATTERY VOLTAGE 12 V for Radio Sets SCR-608-A and SCR-628-A. Don't reverse the nameplate unless 24-volt operation is authorized.)

b. Fastening of Mounting. Secure the mounting to the vehicle frame or other support by bolts passed through two heavy bedplates on the mounting. There are four bolt holes in each bedplate.

Each bedplate supports the mounting through two sets of rubber shock absorbers. In addition, two rubber snubbers on each bedplate prevent excessive movement of the equipment on the mounting. Electrical bonding straps are connected across each rubber shock absorber to provide a good ground connection to the bedplates.

c. Terminals. There are two terminals at the left end of the mounting. Connect the antenna system to the terminal designated TR for radio transmission and reception (Radio Sets SCR-608-A and SCR-628-A) or to the terminal designated REC for reception only. A ground terminal

is provided by a screw on the mounting. Later mountings have a ground binding post located near the antenna terminals for grounding the sheath of coaxial cable (Cordage CO-282).

A door in the base plate of the mounting permits access to the battery fuse (F401), and a terminal strip (TS401). (See Fig. 5.) One of the spare battery fuses is held in a clip on the under side of the door. The positive battery connection is made at the right-hand end of fuse F401. The negative battery connection is made at a screw on the under side of the mounting base plate, which is marked x in Fig. 5. Three methods of running the battery cable, through the right end, front, or rear of Mounting FT-237-(*), are illustrated in Fig. 3.

d. Interconnections Between Units. All connections between the transmitter and receiver units and the mounting are made through multi-contact plugs and receptacles which are automatically engaged when the units are inserted into their proper positions on the mounting. The wiring between receptacles is enclosed in a trough along the rear and left end of the mounting.

7. Radio Receiver BC-683-A.

a. Description of Functions. Radio Receiver BC-683-A is of the superheterodyne type and is intended for reception of frequency-modulated signals within the range of 27.0 to 38.9 megacycles. The receiver can deliver an output of approximately 2 watts to its self-contained loudspeaker or about 200 milliwatts to its headset circuits.

A front view of the receiver is shown in Fig. 6 and an oblique rear view is shown in Fig. 7.

The receiver is turned to ON or to OFF by the switch marked REC.

The front panel contains ten push buttons by means of which any one of ten preadjusted channels may be selected immediately, much the same as any home "touch-tuning" radio. When a push button is fully depressed, it catches and is held in until another push button is *partially* depressed, at which time the first push button releases and the selector mechanism is disengaged. When the selector is disengaged (all push but-

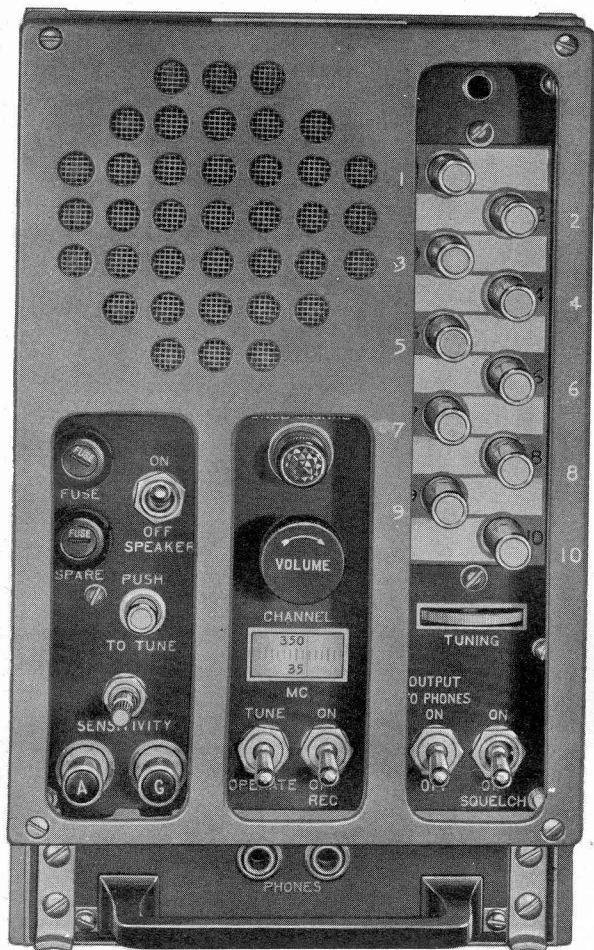

Fig. 6. Radio Receiver BC-683-A: Front View

tons released), the receiver may be tuned by pushing the PUSH TO TUNE push button while rotating the TUNING control.

Two jacks, marked PHONES, are provided for headset operation. The output of the receiver may be connected to the headset circuit by throwing the OUTPUT TO PHONES switch to ON. When the OUTPUT TO PHONES switch is at OFF, the headset circuit is disconnected from the radio receiver. The loudspeaker, however, will still be connected to the receiver output. To use the loudspeaker, place the SPEAKER switch at ON. Regulate the headset and loudspeaker volume by adjusting the VOLUME control.

A noise suppression or "squelch" circuit is switched on or off by the SQUELCH switch. When the SQUELCH switch is at ON, the sensitivity of the receiver is adjusted by the SENSITIVITY con-

trol. When the SQUELCH switch is at OFF, the receiver sensitivity is restored to maximum and cannot be adjusted.

The CALL SIGNAL lamp indicates that a signal is being received provided the SQUELCH switch is at ON and the SENSITIVITY control has been adjusted to prevent operation of the squelch circuit by received noise.

The TUNE-OPERATE switch starts a preset intermediate-frequency oscillator when at TUNE to assist in the adjustment of the channel selector mechanism or to aid in tuning to weak signals. The intermediate-frequency oscillator is also used when aligning or servicing the receiver.

Active and spare fuses are contained in the two fuse receptacles designated FUSE and SPARE.

Antenna and ground binding posts, designated A and G, are provided for testing purposes and special services. These connections are not used when the receiver is installed for operation.

To remove the receiver dust cover turn the fastener on the rear of the cover (see Fig. 7) one-fourth turn to the left and slide the cover off the rear of the receiver. Figure 8 is a view of the left-hand side of the receiver, and Fig. 9 shows the right-hand side of the receiver after removal of the dust cover. Figures 10 and 11 show the receiver push button assembly, viewed from the right side and the front respectively.

b. Power Supply. Radio Receiver BC-683-A is issued with Dynamotor DM-34(*) for operation from a 12-volt vehicle battery. If authorized, the receiver may be operated from a 24-volt vehicle battery by merely substituting Dynamotor DM-36(*) in place of Dynamotor DM-34(*). This is the only change necessary since a multi-contact jack on the base of each dynamotor is wired to make the necessary circuit changes.

8. Radio Transmitter BC-684-A.

a. Description of Functions. The transmitter operates in the frequency band from 27.0 to 38.9 megacycles and delivers a nominal power output of 20 watts to its antenna system. The carrier is frequency-modulated. A maximum frequency deviation of plus or minus 80 kilocycles (total frequency swing, 160 kilocycles) can be ob-

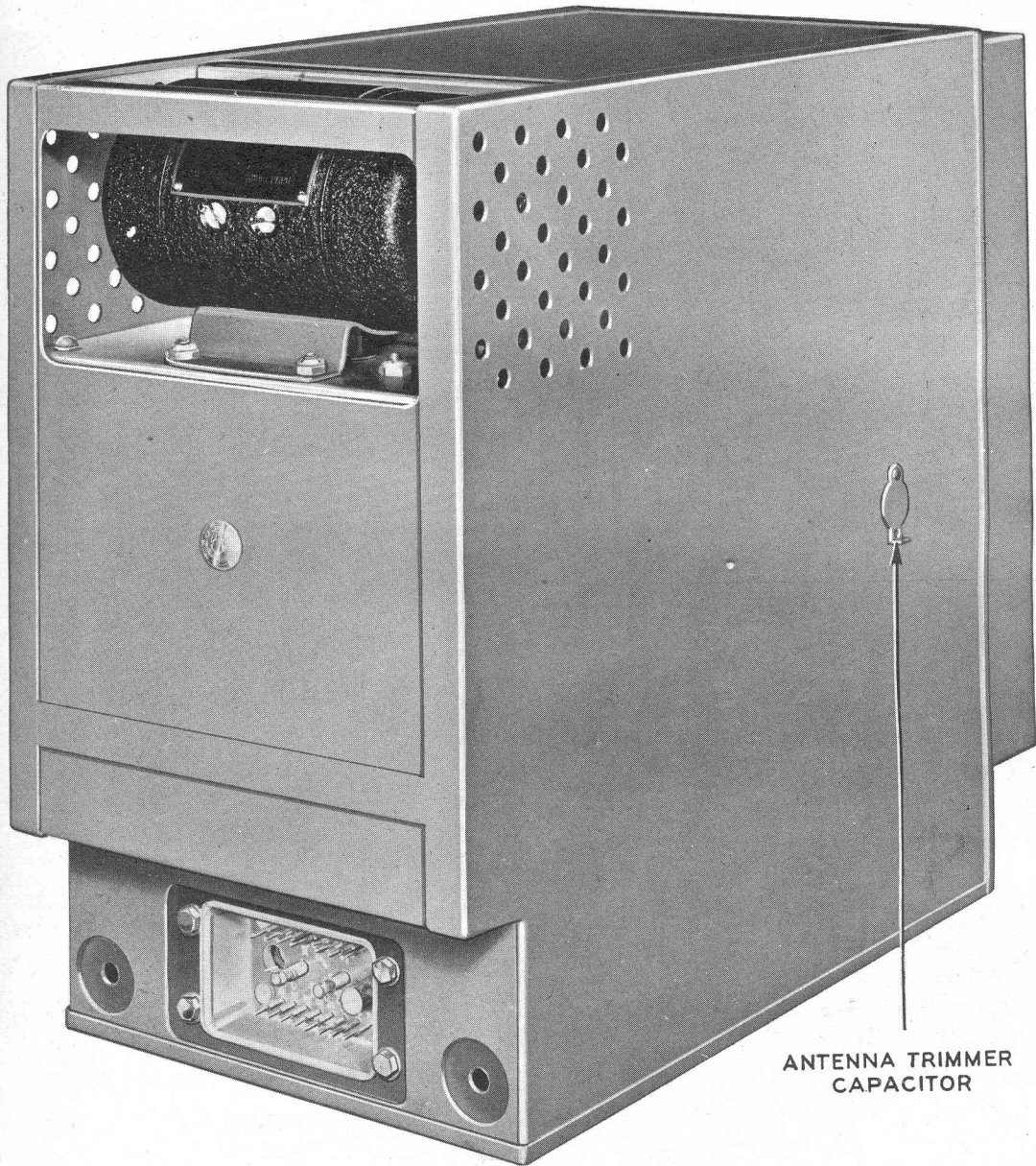

ANTENNA TRIMMER
CAPACITOR

Fig. 7. Radio Receiver BC-683-A: Oblique Rear View

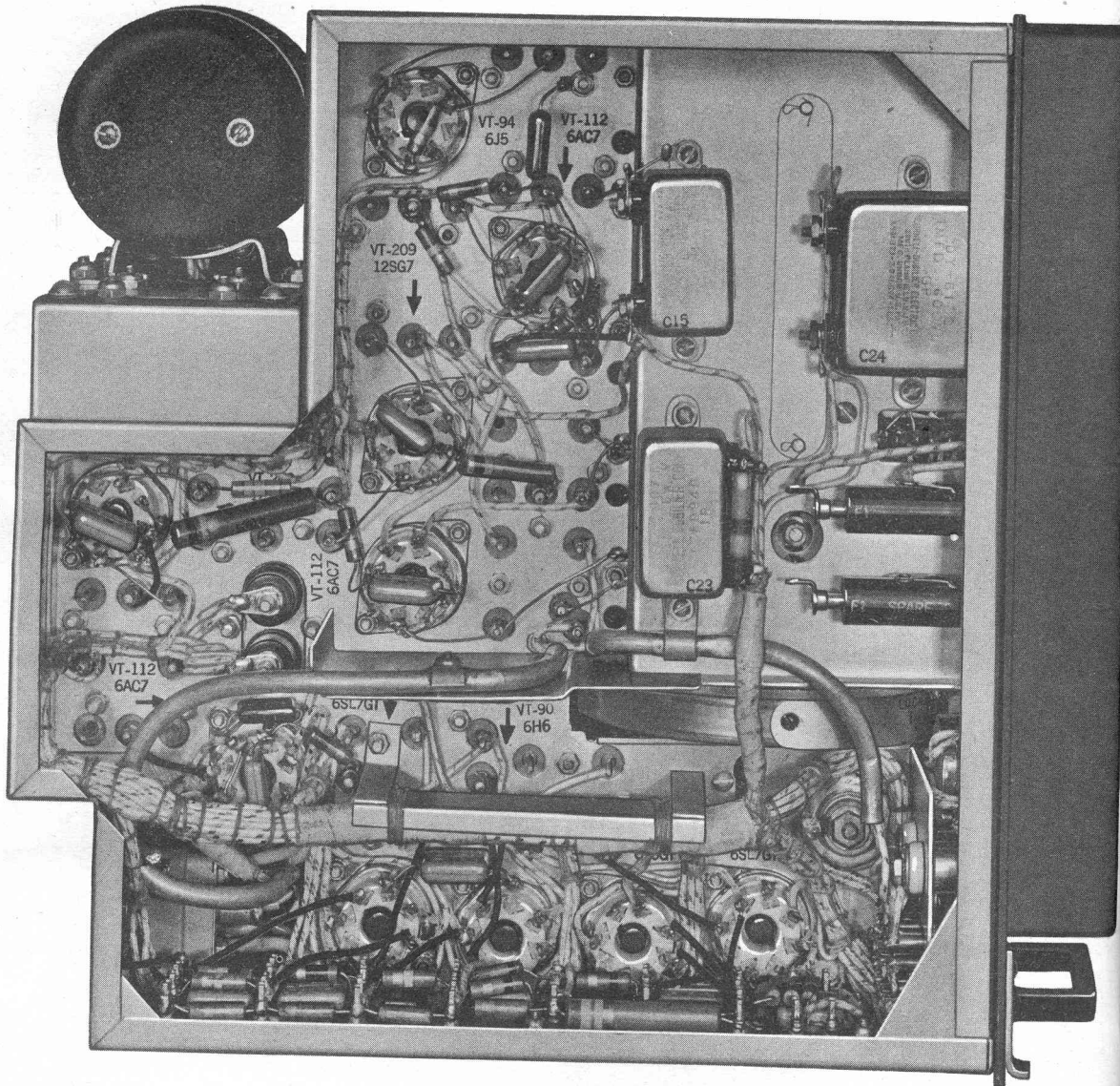

Fig. 8. Radio Receiver BC-683-A: Left-hand Interior View

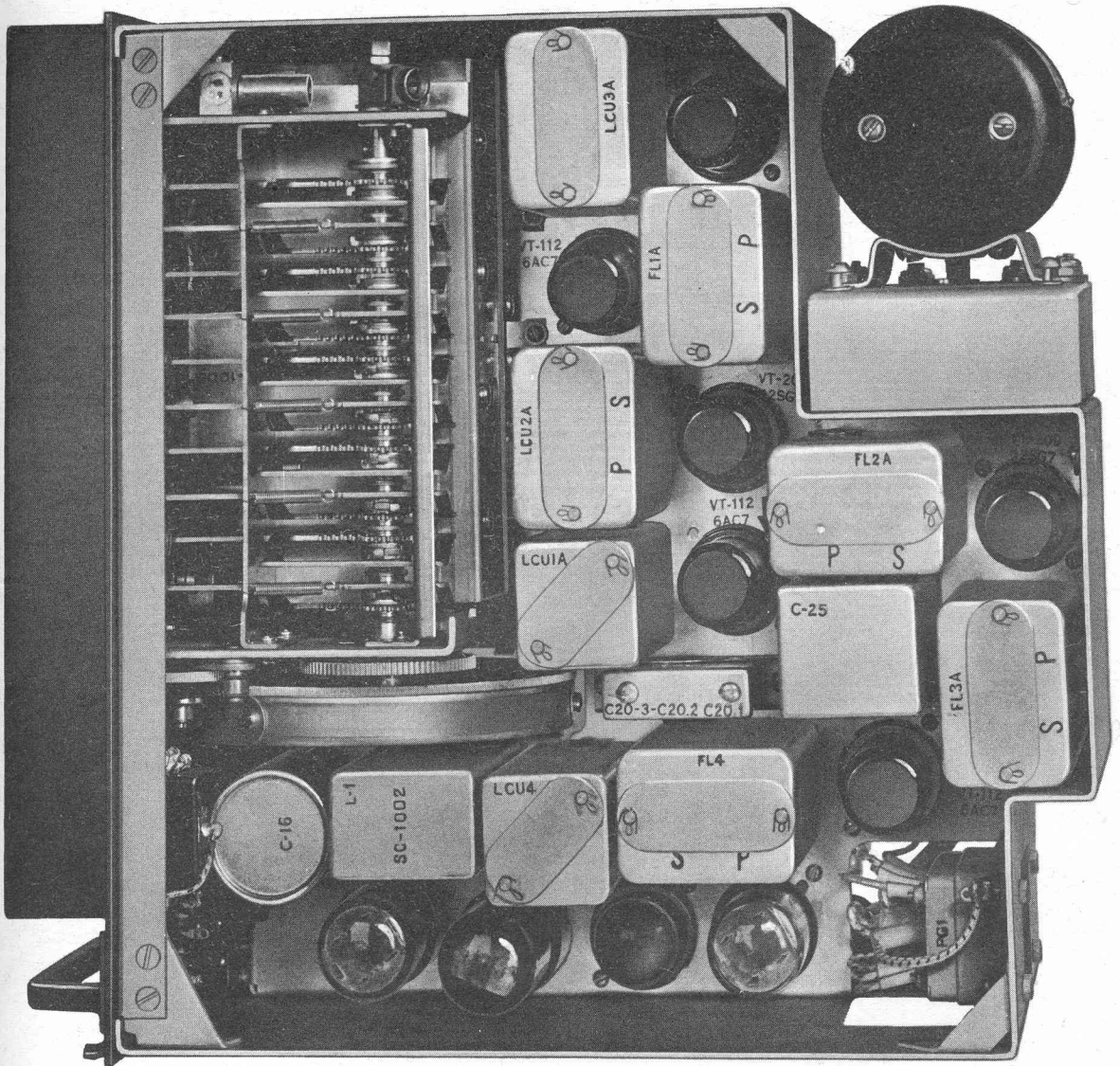
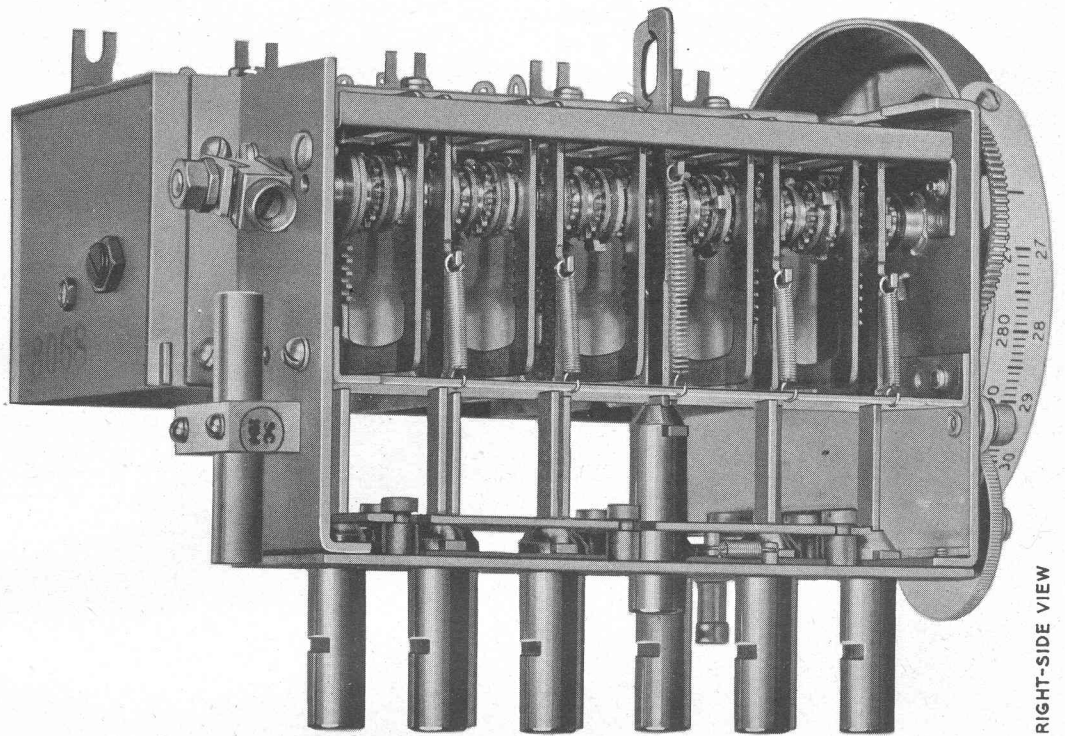
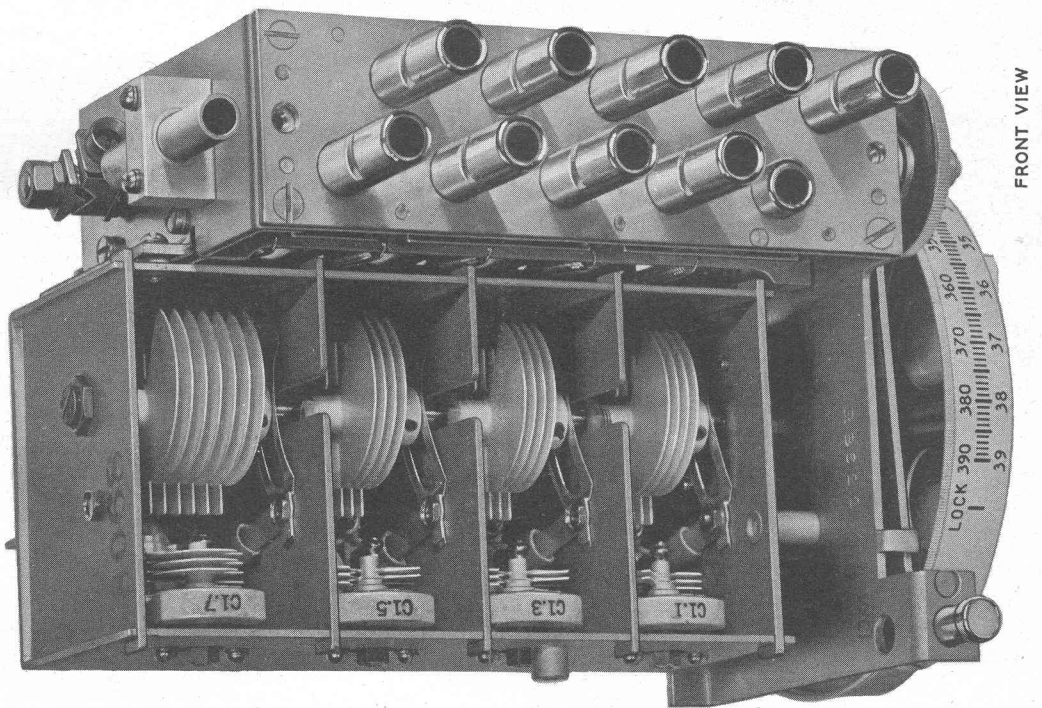

Fig. 9. Radio Receiver BC-683-A: Right-hand Interior View



RIGHT-SIDE VIEW

Fig. 10. Radio Receiver BC-683-A: Push-button Assembly, Right-side View



FRONT VIEW

Fig. 11. Radio Receiver BC-683-A: Push-button Assembly, Front View



Fig. 12. Radio Transmitter BC-684-A: Front View with Crystal Compartment Open

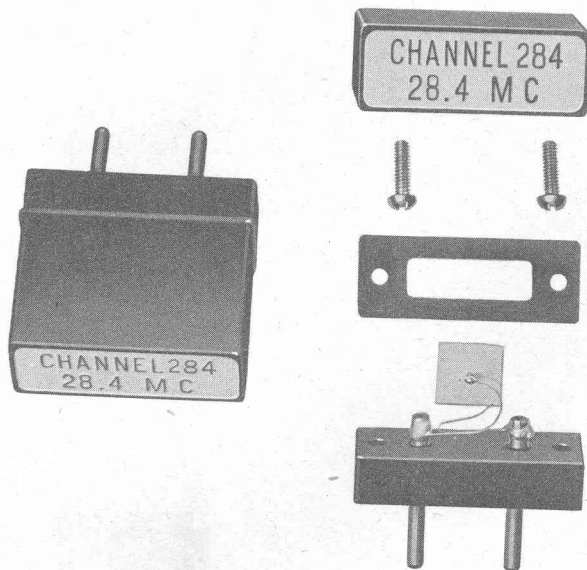

Fig. 13. Radio Transmitter BC-684-A: Assembly and Exploded View of Crystals

tained; ordinarily, however, the frequency deviation is much less than this. Under most operating conditions the deviation, even on voice peaks, is less than plus or minus 40 kilocycles (total swing, 80 kilocycles).

A front oblique view of the transmitter is shown in Fig. 1 (large unit at the left). Figure 12 is a closer front view and Fig. 13 shows assembly and exploded views of typical crystals. A view of the right-hand end of the transmitter showing the various controls and access openings is given in Fig. 14.

The front panel contains ten push buttons by means of which any of ten preadjusted transmitting channels may be immediately selected. This operates exactly like the push-button type of broadcast radio for the home. Like the receivers, you merely push one of several buttons on the front of the set to select the channel you want. Antenna and ground binding posts, designated A and G, are provided for test purposes, and they are not normally used when the transmitter is installed for operation. The RECEIVER TUNE-OPERATE switch makes it possible to use the transmitter as a source of known signal frequency for adjustment and testing of associated radio receivers. The transmitter filaments and relay circuits are energized by the ON-OFF switch and

transmission is started by operating the control switch on the operator's microphone. The pilot lamp lights when the TRANSMITTER switch is at ON. Plug microphones of the carbon type, such as Microphone T-17 and Microphone T-30, into the CARB MIC jack. Connect Microphone T-33, which is of the magnetic type, at the MAGNETIC MIC jack.

Active and spare fuses are contained in the two fuse receptacles designated FUSE and SPARE.

The panel meter may be connected in various circuits by means of the TUNE-ANT CUR switch on the panel and the six-position METER SWITCH (Fig. 14) to observe transmitter output and circuit operating conditions. The meter is not calibrated in milliamperes or other standard unit of measure as it is used only as an indicator of relative current flow.

The SIDETONE control shown in Fig. 14 adjusts the volume of transmitted speech heard in the operator's headset. The ten screwdriver-operated controls are for antenna tuning adjustments.

Remove the top or bottom cover plates for access to the interior of the transmitter. Figure 15 is a view of the interior with the top cover plate removed. Figures 16 and 17 show the transmitter push-button assembly viewed from the left and from the right side respectively. A view of the interior with the bottom cover plate removed is shown in Fig. 18.

b. Power Supply. Radio Transmitter BC-684-A is furnished with a dynamotor, Dynamotor DM-35-(*), suitable for operation from a 12-volt vehicle battery. If authorized, the transmitter may be operated from a 24-volt vehicle battery by merely substituting Dynamotor DM-37-(*), in place of Dynamotor DM-35-(*). This is the only change necessary, since a multicontact jack on the base of each dynamotor is wired to make the necessary circuit changes. *The design of Dynamotors DM-35-(*), and DM-37-(*), is based on an average duty cycle of 5 minutes on and 15 minutes off at high temperatures. Don't operate the transmitter dynamotors continuously over long periods. You might burn out your dynamotor.*

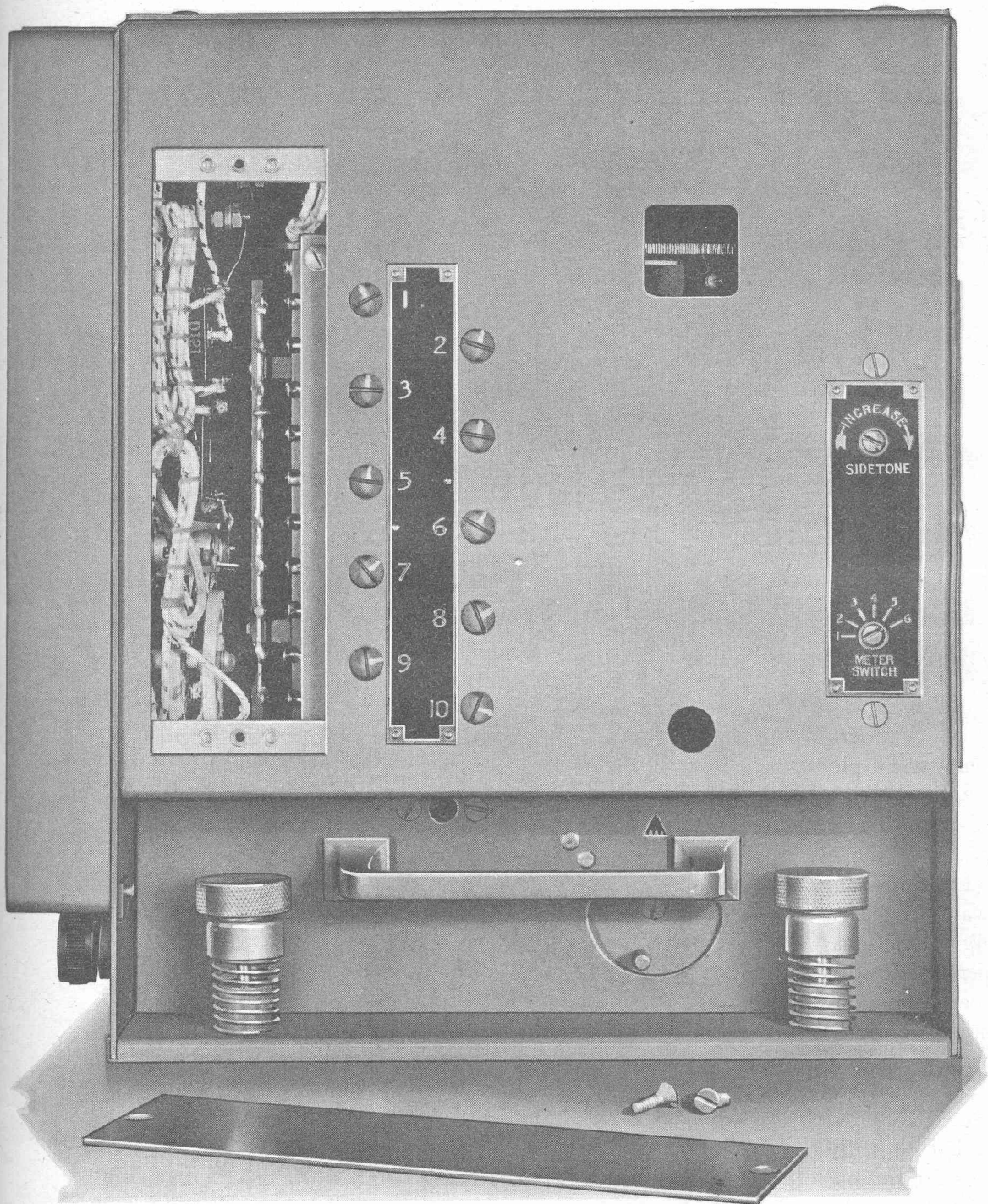

Fig. 14. Radio Transmitter BC-684-A: Right-hand End View with Cover Plate Removed

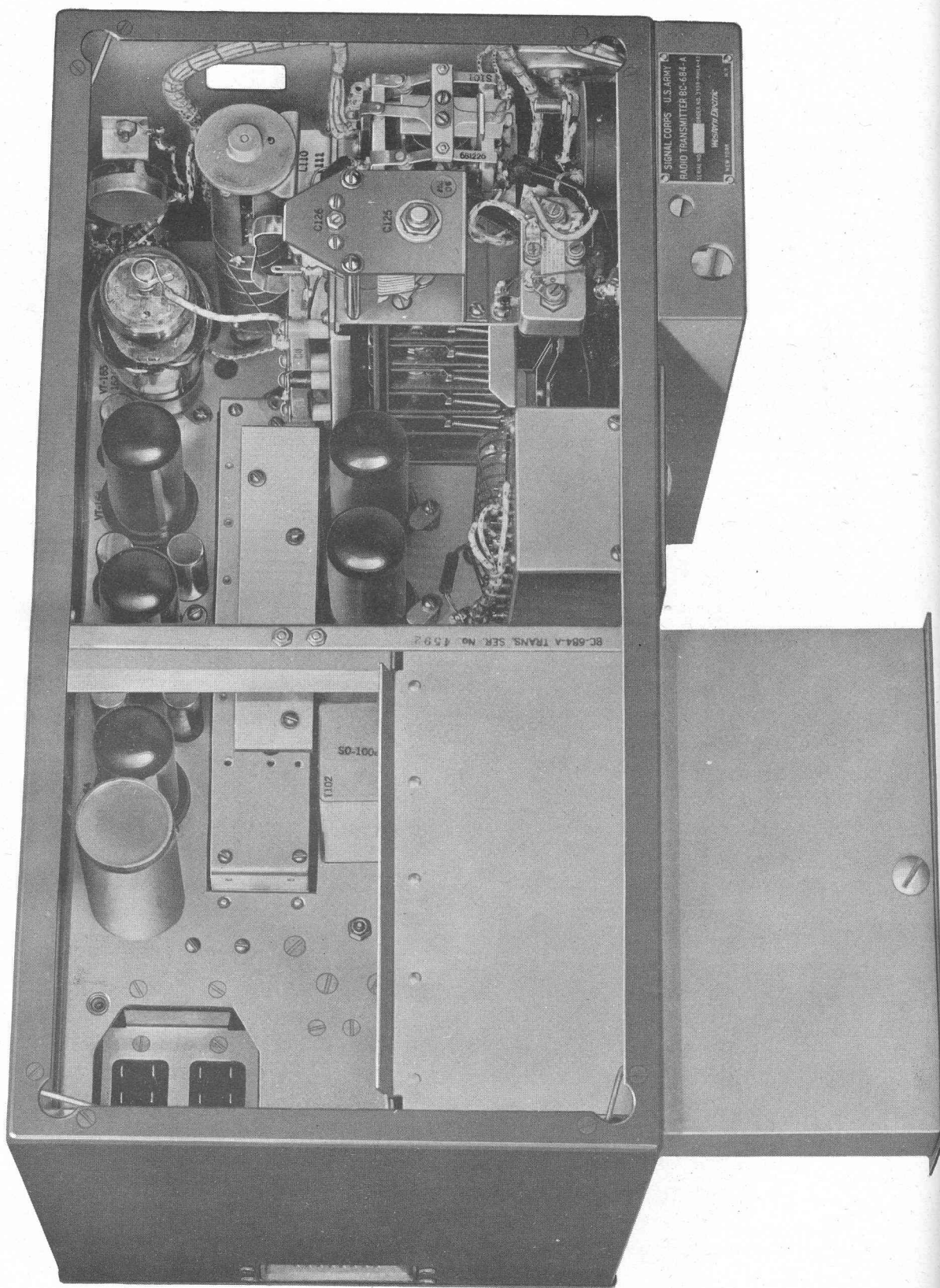
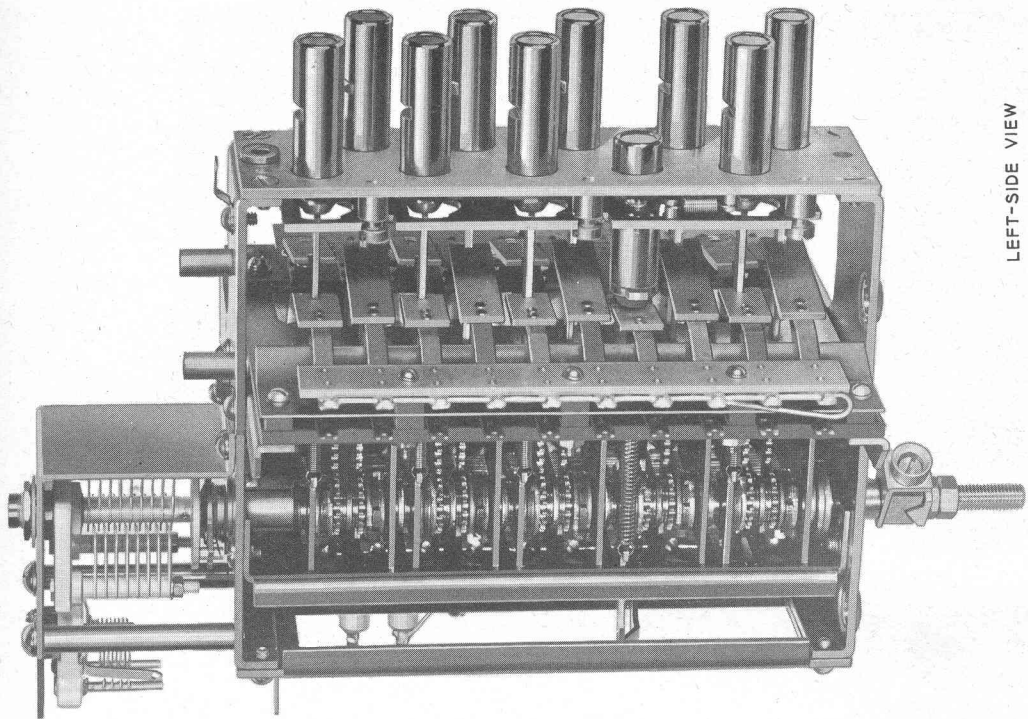
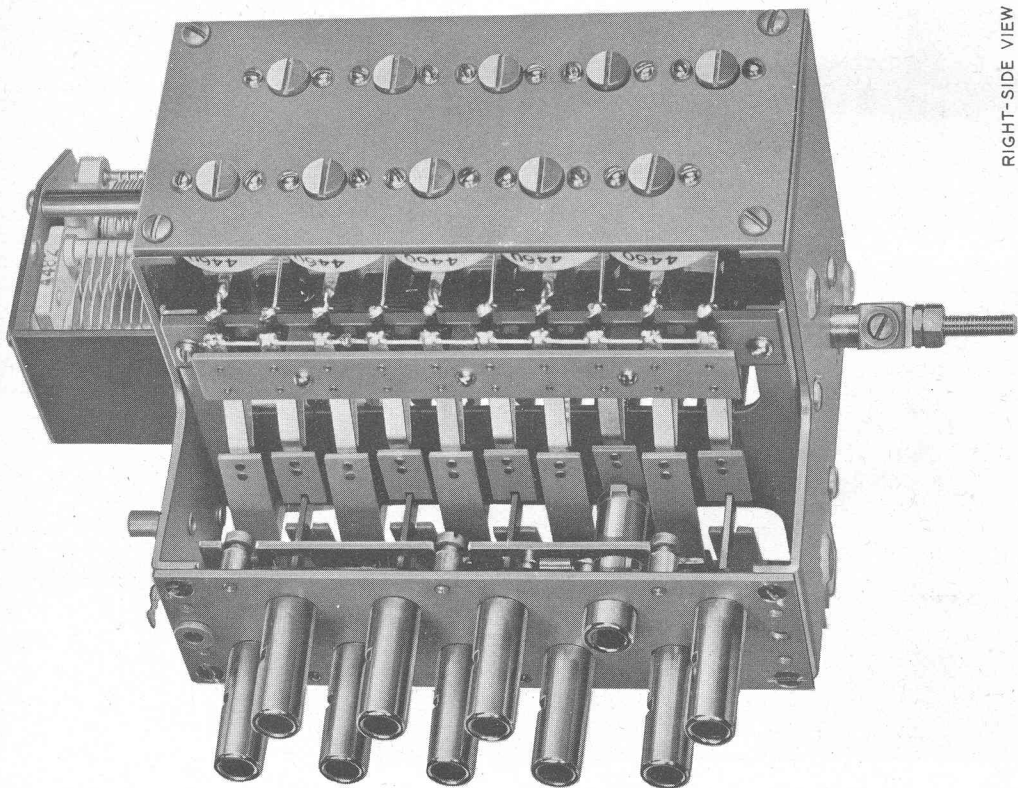

Fig. 15. Radio Transmitter BC-684-A: Interior View with Top Cover and Dynamotor Removed



LEFT-SIDE VIEW

Fig. 16. Radio Transmitter BC-684-A: Push-button Assembly, Left-side View



RIGHT-SIDE VIEW

Fig. 17. Radio Transmitter BC-684-A: Push-button Assembly, Right-side View

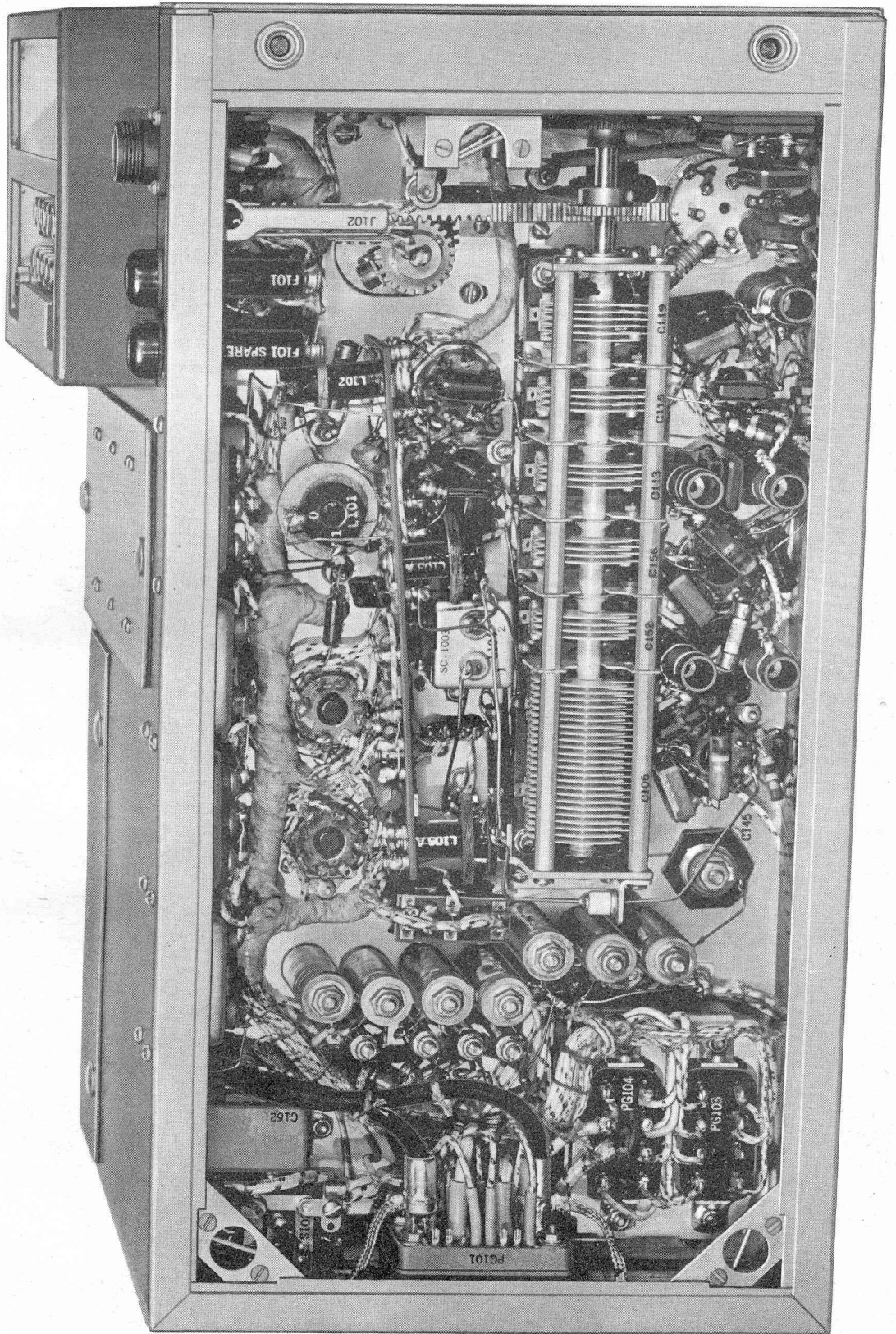

Fig. 18. Radio Transmitter BC-684-A: Interior View with Bottom Cover Removed

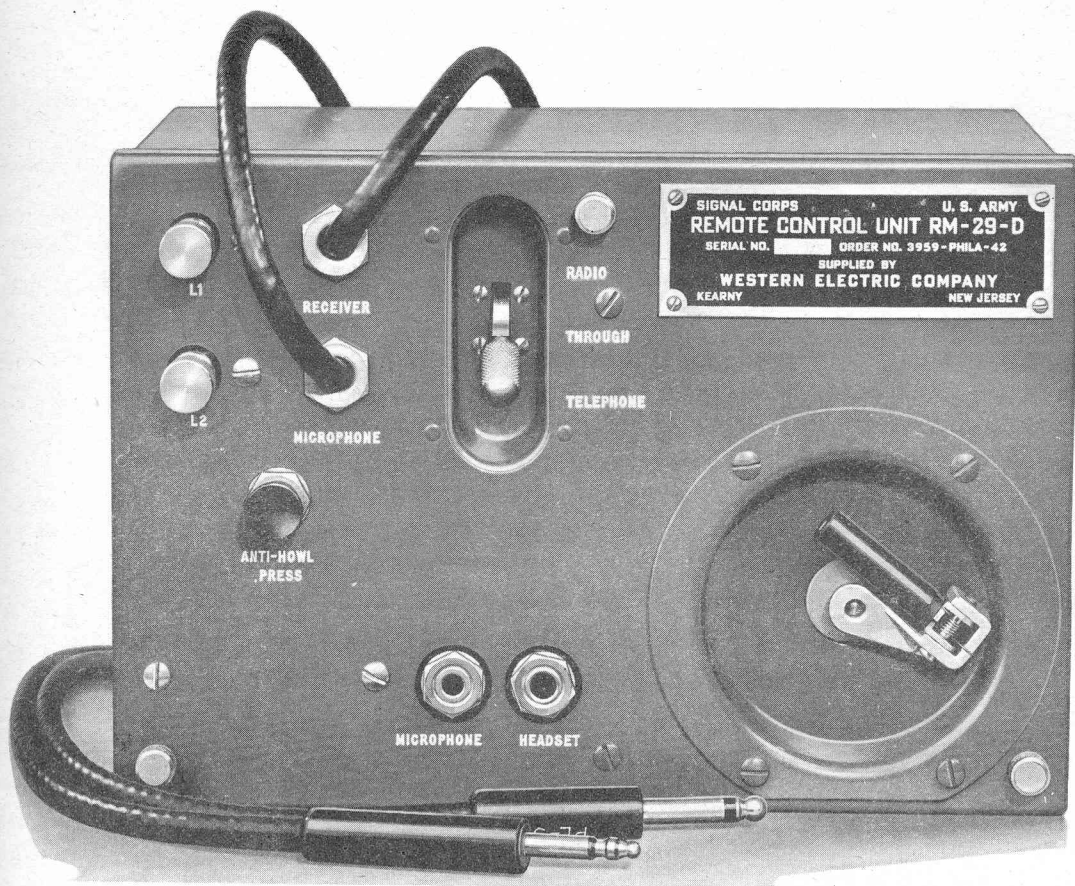

Fig. 19. Remote Control Unit RM-29-D: Front View

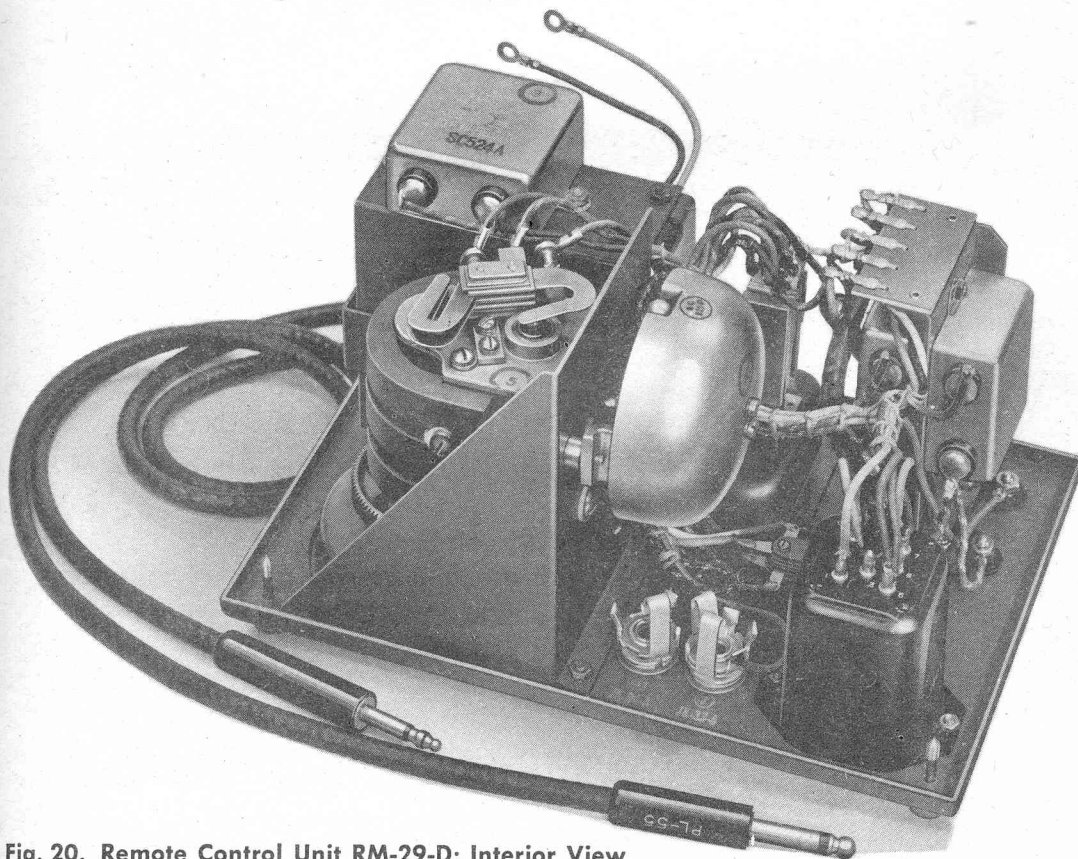

Fig. 20. Remote Control Unit RM-29-D: Interior View

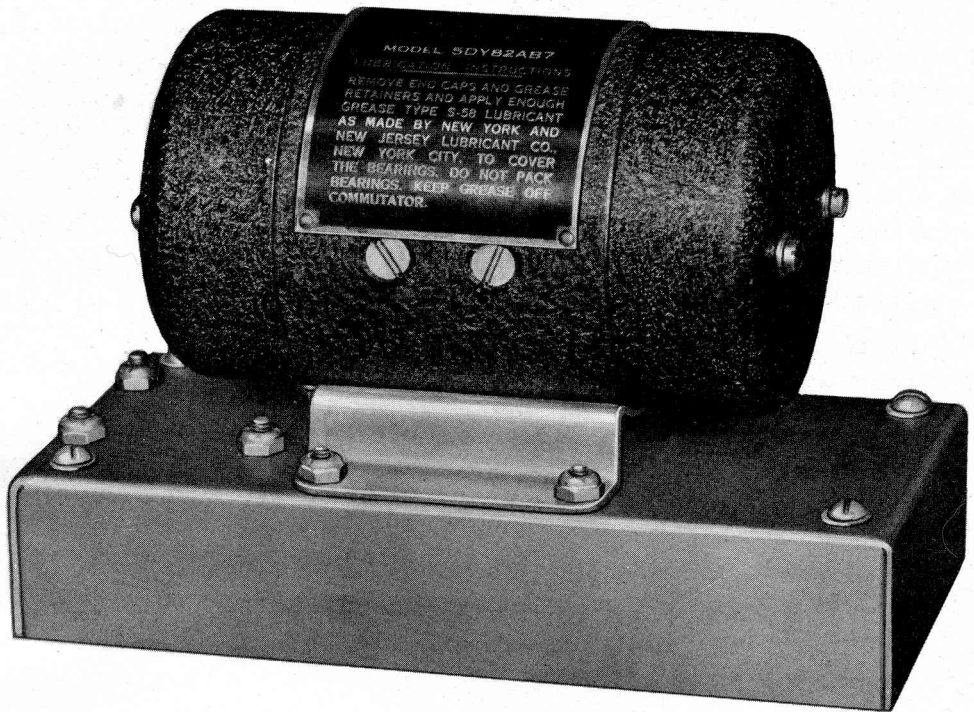

Fig. 21a. Dynamotor DM-34-(*) or Dynamotor DM-36-(*)

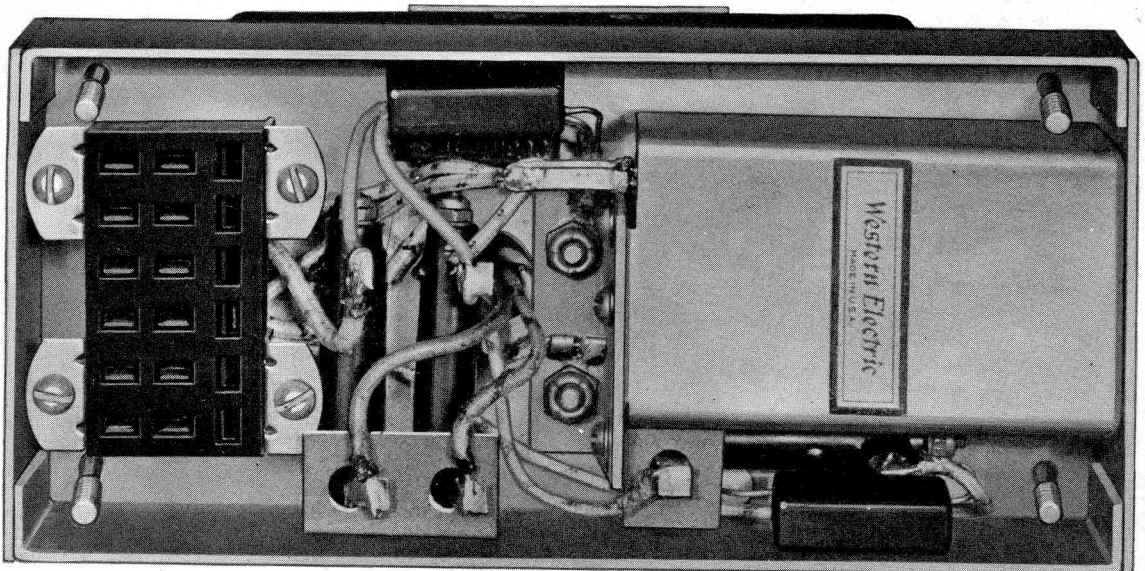

Fig. 21b. Dynamotor DM-34-(*) or Dynamotor DM-36-(*): Sub-base View

9. Remote Control Unit RM-29-D.

Note: The information regarding Remote Control Unit RM-29-D in this and subsequent paragraphs is given to assist radio operators in setting up Radio Sets SCR-608-A and SCR-628-A for remote control operation. Do not regard this information as complete, but refer to Technical Manual TM 11-308, covering the remote control unit, for detailed information and instructions.

a. Description of Functions. Remote Control Unit RM-29-D provides for remote control of the radio equipment and operates in conjunction with Telephone EE-8-(*) over a two-wire telephone line. A front view of the remote control unit is shown in Fig. 19, and an internal view with the housing removed is shown in Fig. 20.

Two plug-terminated cords are provided to connect the remote control unit to the radio transmitter and radio receiver. The two-wire telephone line from the remotely located field Telephone EE-8-(*) terminates at binding posts L1 and L2 on the remote control unit. Microphone T-17 and a headset, when plugged into the remote control unit, are used for transmission and reception of signals via the radio set, for monitoring signals between the telephone and the radio set, and for direct communication with Telephone EE-8-(*) .

The three modes of operation are selected by the switch marked RADIO-THROUGH-TELEPHONE on the front of the remote control unit. Operation is as follows:

(1) *Switch at RADIO.* The radio set is controlled entirely by the operator stationed at the remote control unit, with the switch at RADIO. The operator can transmit and receive signals via the radio set.

(2) *Switch at THROUGH.* The radio set is still under control of the operator at the remote control unit with the switch at THROUGH. However, this operator can no longer transmit via the radio set, but can only monitor all signals passing over the line, both from the radio receiver to any Telephone EE-8-(*) connected to the telephone line from the remote control unit, and from any telephone to the radio transmitter.

(3) *Switch at TELEPHONE.* The remote control unit functions as a telephone very similar to Telephone EE-8-(*) with the switch at TELEPHONE, and the operator can communicate with any telephone connected to the telephone line, but is disconnected from the radio equipment.

b. Power Supply. One Battery BA-27 (4½ volts) is mounted inside the remote control unit for operation of Microphone T-17. The current drain from this battery is from 50 to 95 milliamperes, depending on the position of the microphone.

10. Dynamotors DM-34-(*), DM-35-(*), DM-36-(*), DM-37-(*) .

a. Dynamotors DM-34-() and DM-36-(*) .* Each of these dynamotors provides about 200 volts for operation of the receiver. The dynamotors are of similar appearance; and two views are shown in Fig. 21a and Fig. 21b. The dynamotors are totally enclosed. Their armatures are dynamically balanced and are supported by two single-race ball bearings. Both dynamotors are shunt wound. The primary and secondary windings are wound in the same armature slots, but the two windings are brought out to separate commutators mounted on opposite ends of the armature shaft.

b. Dynamotors DM-35-() and DM-37-(*) .* Each of these dynamotors provides approximately 625 volts for operation of the transmitter. The dynamotors are of similar appearance; and two views are shown in Fig. 22a and Fig. 22b. Except for screened breathing vents in the end covers, the dynamotors are totally enclosed. The screened holes have been omitted in later dynamotors to reduce the entrance of dust or sand. This does not affect the power rating of the dynamotors. Their armatures are dynamically balanced and are supported by two single-race ball bearings. Both dynamotors are compound wound. The primary and secondary are wound in the same armature slots, but the two windings are brought out to separate commutators mounted on opposite ends of the armature shaft.

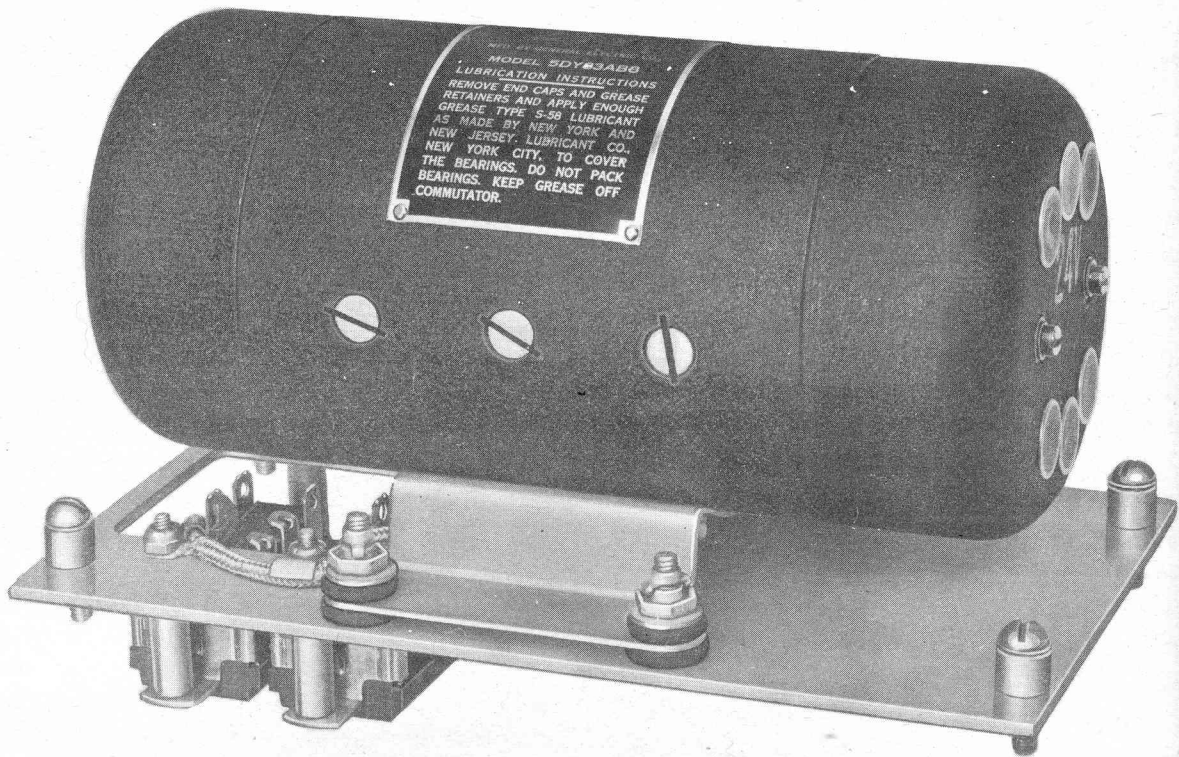

Fig. 22a. Dynamotor DM-35-(*) or Dynamotor DM-37-(*)

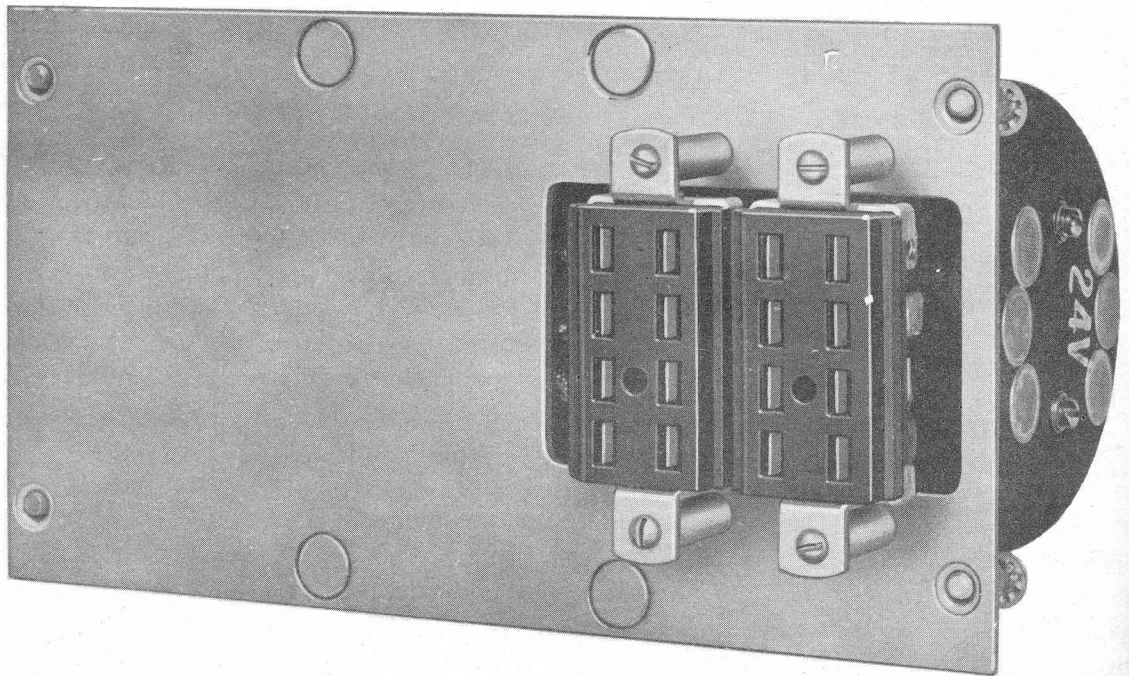

Fig. 22b. Dynamotor DM-35-(*) or Dynamotor DM-37-(*): Sub-base View

c. 12- or 24-Volt Operation. Dynamotor DM-34-(*) for the receiver and Dynamotor DM-35-(*) for the transmitter are designed for operation from a 12-volt vehicle battery supply. These dynamotors are issued with Radio Sets SCR-608-A and SCR-628-A which will normally be operated from a 12-volt battery. However, as mentioned in Paragraphs 7*b* and 8*b*, the receiver and transmitter can be operated in vehicles having a 24-volt battery supply. To do this, it is only necessary to substitute Dynamotors DM-36-(*) and DM-37-(*) for Dynamotors DM-34-(*) and DM-35-(*) in the receiver and transmitter, respectively. Dynamotors DM-36-(*) and DM-37-(*) operate from a 24-volt battery supply.

11. Cabinet CH-74-A. Cabinet CH-74-A is a protective housing for the radio equipment in installations where the equipment would otherwise be exposed to the elements (see Fig. 1). Cabinet CH-74-A is supported within the vehicle by Mounting FT-284-(*), Mounting FT-285-(*), or Frame FM-43, depending upon which vehicle is being used. Mounting FT-237-(*) is bolted in place in the cabinet. The top of the cabinet extends somewhat over the front of the radio equipment. A canvas cover assembly is provided for the front of the cabinet to completely enclose the radio equipment, if desired. The canvas cover may be rolled back over the top of the cabinet, or it may be supported by a bracket which telescopes into the top of the cabinet. Except in an emergency, do not operate the equipment during hot weather with the canvas cover completely closed. *Even in an emergency, do not operate either the transmitter or the receiver long enough for the equipment to overheat before the cover is raised.*

12. Mountings FT-284-(*) and FT-285-(*) and Frame FM-43. Mountings FT-284-(*) and FT-285-(*) and Frame FM-43 are used to support Cabinet CH-74-A in vehicles where the cabinet is used. The choice among these mountings depends upon the particular vehicle in which the radio equipment is to be installed. (See Paragraph 3*b*.) Figure 1 shows an installation using Mounting FT-284-(*).

13. Mast Bases.

a. Mast Base MP-37. This mast base provides an insulated and flexible mounting for the antenna; it is rigidly mounted on the vehicle but includes a large helical spring for flexibility. Mast Section MS-53, the largest, screws into this base.

b. Mast Base MP-48. Another way to have a flexible antenna support is to use Mast Base MP-48. Use this base with a coaxial transmission line such as Cordage CO-282. Two binding posts permit use of a single wire lead (Wire W-128).

14. Mast Base Bracket MP-52. Mast Base Bracket MP-52 serves to support an antenna and mast base about two feet above Cabinet CH-74-A. Clamp the mast base to the bracket cover plate and bring the antenna lead down through insulating guides into the cabinet for connection to the radio equipment. The bracket is fastened to the cabinet by 12 bolts. (See Fig. 1.)

15. Mast Sections. Mast Sections MS-51, MS-52, and MS-53 are used with these radio sets, except that only two mast sections (MS-52, MS-53) are to be used with Mast Base Bracket MP-52. (Mast Base Bracket MP-52 is used in half-track installations and is mounted on the top of Cabinet CH-74-A at the left front corner.) The mast sections are made of high-tensile-strength flexible steel. Mast Section MS-51 is the top (and smallest) section. The others follow in numerical order. The lower end of each mast section is fitted with a serrated (notched) shank and screw for engaging the threaded upper end of the next mast section. Ends which are joined in assembling have enamel marks of the same color. The body of each section is enameled black and bears the type number at the lower end. The lower end of each mast section has an entering guide to aid assembly. Store the mast sections in Roll BG-56-A when not in use.

16. Cords and Cordage.

a. Cord CO-278-A. Cord CO-278-A is used to connect Mounting FT-237-(*) to the terminal box (battery) of the vehicle. It consists of 8 feet

of Cordage CO-212 to which connection terminals have been soldered. The inner conductor is connected to the positive side of the battery and the outer conductor is grounded.

b. Cord CD-307-A. Cord CD-307-A in two lengths, 48 inches and 65 inches, extends the radius within which the crew of the vehicle may receive signals in their headsets. Plug PL-55 at one end of Cord CD-307-A plugs into the radio receiver. The headset plug is connected into Jack JK-26 at the other end of Cord CD-307-A.

c. Cord CD-318. Cord CD-318 is a 7-foot cord assembly for connection between the short cord supplied with Microphone T-30 and the radio equipment or a remote control box. The assembly includes Switch SW-141-E for control of the microphone current, provided with a neck strap for its support. The neck strap quickly detaches from the switch.

d. Cord CD-786. The auxiliary Cord CD-786 provides for making thirteen connections to a receiver or transmitter when not installed in the mounting. One such use is testing a receiver on a bench. The cord consists of

(1) A male plug for insertion in the socket J401, J402, or J403 of Mounting FT-237-(*).

(2) A receptacle for connection to the plug PG1 of the receiver, or PG101 of the transmitter.

(3) Six feet of cordage containing conductors to connect corresponding numbers in these two plugs.

Terminals 1 and 2 of the plug are connected to corresponding numbers in the receptacle by 10-gauge stranded wires. This constitutes the power connection and is suitable for carrying several amperes. A 22-gauge twisted, shielded pair of stranded wire is used for terminals 4 and 5. The other terminals used are numbers 7, 8, 9, 10, 19, 20, 21, 22, and 25.

e. Cordage CO-212. Cordage CO-212 is composed of two concentric conductors and is used in making Cord CO-278-A. Cordage CO-212 is supplied in bulk lengths and is used to replace damaged Cords CO-278-A or where a longer cord is needed. The cordage is installed so that the inner conductor is positive and the outer conductor is at ground potential.

f. Cordage CO-282. Cordage CO-282 is a flexible two-conductor coaxial cordage intended for transmission of high-frequency currents. It is used in all installations of Radio Sets SCR-608-A and SCR-628-A where the distance between the binding post on Mounting FT-237-(*) and the mast base is more than 40 inches. The length of Cordage CO-282 must *always* be 7 feet (plus or minus 1 foot). If 7 feet is more than is needed, tape up the excess in a coil. Be sure to ground the sheath at both ends.

WAR DEPARTMENT TECHNICAL MANUAL

TM 11-620

RADIO SETS

SCR-608-A AND SCR-628-A

WAR DEPARTMENT • 1 JANUARY 1944

SECTION II. INSTALLATION AND OPERATION

17. Initial Procedure.

a. Unpacking. Check the containers *before* opening them. Be careful when unpacking or handling the equipment. Avoid damage. Carefully inspect each unit for damage incurred in shipment and for loose parts. Remove all dust covers and inspect the interiors. *Very carefully* blow or brush out any dust or dirt. If an air gun is used, *be sure* that the air is free from water, oil, and grit. *Avoid displacing or damaging any apparatus or wiring.* Manually check operation of the push buttons and other controls on each unit.

b. Preparation for Installation.

(1) Determine whether the vehicle battery is 12 or 24 volts and set the reversible voltage designation plate on the front of the mounting so that it properly describes the battery in use. (See Fig. 4.)

(2) Open the hinged door on the mounting and check for the presence of a 75-ampere fuse in the circuit and in the spare fuse clip on the door. (See Fig. 5.)

(3) Remove the unnecessary dust covers from the receptacles on the mounting and mount them in the positions provided at the back of the mounting.

(4) Using Table IV, select the proper dynamotor for installation in each of the units.

Table IV. Selection of Dynamotors

Unit in Which Dynamotor is Required	Dynamotor for Use With a Vehicle Battery of	
	12 Volts	24 Volts
Receiver	DM-34-(*)	DM-36-(*)
Transmitter	DM-35-(*)	DM-37-(*)

(5) Remove the dust cover from the receiver, insert the proper dynamotor in place, and make certain that the dynamotor receptacles properly engage the plugs on the receiver. Tighten the four hold-down screws of the dynamotor and replace the receiver dust cover.

(6) Remove the top cover plate from the transmitter. Take out the crystal storage drawer by pulling the drawer all the way out and lifting up the front end. Insert the proper dynamotor and make certain that the dynamotor receptacles properly engage the plugs on the transmitter. Tighten the four hold-down screws, using a long, thin screwdriver. Replace all parts that were removed.

(7) Open the cover of the transmitter crystal storage drawer and remove the crystal compartment cover plate. Check the number of crystal holders in both places. Do not remove any crystals found in the crystal compartment, since they will be used for subsequent installation tests.

18. Installation.

a. Preparation of Vehicle. Detailed information on installation of the radio sets in various types of vehicles are to be found in the installation instructions for the particular type of vehicle concerned.

b. Installation of Equipment.

(1) *Check the vehicle battery and the battery designation plate on the mounting.* Shine up the contact areas around the mounting bolt holes on the mounting and the corresponding areas on the vehicle or the adapter plate to insure a good contact when the mounting bolts are tightened. *A good ground connection must be made at these points or the radio set will not function properly. Watch this.* Place the mounting in its assigned position with the bolt holes in the two bedplates aligned with the holes in the vehicle or the adapter plate. Select the required mounting bolts from the bolts furnished with the mounting and tighten them firmly in place.

(2) Install Cord CO-278-A, which connects the mounting to the vehicle terminal box, in the mounting in a manner to prevent its damage by personnel (especially by their feet) and by movement of the mounting on its shock absorbers. Three sets of holes in the mounting

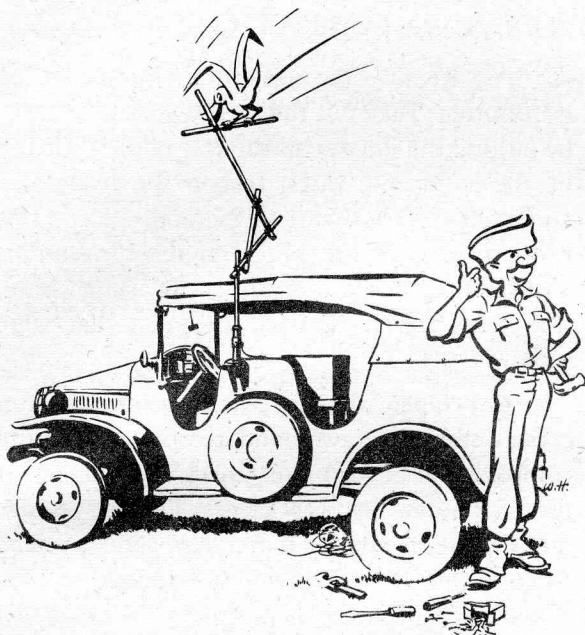

DON'T DESIGN YOUR OWN ANTENNA!
- STICK TO WHAT'S RECOMMENDED

make possible the entrance of Cord CO-278-A from any one of three directions, as shown in Fig. 3. Use the holes which will result in the cleanest and shortest installation. The center conductor connects to the *positive* or ungrounded side of the terminal box. The outer conductor connects to the *negative* or grounded side of the terminal box. One end of the cord has smaller terminal lugs than the other end. Connect the smaller lugs to the mounting with the lug on the center conductor connecting to fuse F401 and the lug on the outer conductor connecting to the ground screw on the mounting (marked X in Fig. 5). *Do not connect the battery (terminal box) end of Cord CO-278-A without checking for accidental ground on the mounting. Check the polarity.*

(3) Antenna and ground connections differ somewhat for each type of vehicle, but make the installation in accordance with the general information contained in Paragraph 4a. The TR binding post on Mounting FT-237-(*) is used for the antenna connection when both transmission and reception are desired. Use the REC binding post for reception only.

(4) Check the dynamotor installed in the transmitter to make sure it is of the proper type

for the vehicle battery voltage. If not, replace the dynamotor with one of the proper voltage rating. Replace the cover plate. Place the transmitter on the mounting base with the push buttons toward the front of the mounting. Slide the transmitter to the left until the transmitter plug firmly engages the receptacle on the end of the mounting. The guides and tapered pins on the mounting properly align the transmitter as it is pushed into place. The two thumbscrews at the right-hand end of the transmitter may then be pressed down to engage the threaded holes in the mounting and firmly turned to the right to lock the transmitter in place.

(5) Make certain that the dynamotor installed in each receiver is correct for the vehicle battery employed. If two receivers are to be used (Radio Set SCR-608-A), they may be placed in either of the two positions on the mounting (see Fig. 1). When only one receiver is used (Radio Set SCR-628-A), place it in the right-hand position to give yourself enough room to get at the adjustments on the right end of the transmitter (see Fig. 2). Slide the receiver toward the rear of the mounting until its plug engages with the receptacle. The tapered pins properly align the receiver to engage the receptacle. Engage the cupped edges of the thumbscrews on the mounting with the hold-down brackets. Then tighten the thumbscrews.

(6) To install Remote Control Unit RM-29-D follow the instructions provided with this unit.

19. Preparation for Use.

a. Receiver.

(1) *Performance Check.* Here's how to check receiver performance:

(a) Turn the REC switch to ON and make certain that the receiver dynamotor starts. After about 15 seconds the vacuum tubes will be heated sufficiently for operation of the receiver.

(b) Set the SPEAKER switch to ON, the SQUELCH switch to OFF, and the OUTPUT TO PHONES switch to ON. Plug a Headset HS-30-

(*), HS-18, or HS-23 into one of the PHONE jacks.

(c) Turn the VOLUME control all the way to the right. If it's on the air, you should hear noise, or a signal, from the loudspeaker and in the headset. The volume of sound may be varied by adjusting the VOLUME control. The CALL SIGNAL lamp should light.

(d) Turn the SQUELCH switch to ON and observe the CALL SIGNAL lamp while turning the SENSITIVITY control. It should be possible to extinguish the CALL SIGNAL lamp by turning the SENSITIVITY control to the left; the CALL SIGNAL lamp may not always light when no signal is being received. The noise, or signal, from the loudspeaker should cease whenever the CALL SIGNAL lamp goes out.

(e) Turn the SQUELCH switch to OFF and listen to the noise while pressing the PUSH TO TUNE push button and operating the TUNING control. Noise or signals should be heard at any dial setting. An unmodulated signal (a station on the air but not talking) will sometimes cause a reduction of noise at one dial setting. The noise should increase as the dial is turned either side of such a station.

(2) *Receiver Antenna Tuning.* In making the following adjustments, place the receiver in the vehicle and connect the antenna. Don't let the antenna touch anything and locate your vehicle in the open, but *only* to the extent permitted by camouflage requirements.

(a) Install the receiver in the *right-hand* position on the mounting and set the ON-OFF switch to ON. The *left-hand* position must be vacant.

(b) Set the SQUELCH switch to OFF and the TUNE-OPERATE switch to OPERATE.

(c) Set the SPEAKER switch to ON. (If you wish you may use a headset instead of the loudspeaker, in which case set the SPEAKER switch to OFF and the OUTPUT TO PHONES switch to ON.)

(d) Release the push buttons (see Paragraph 7).

(e) Manually tune the receiver to a frequency near the high-frequency end where there

is *noise* (not a signal). To manually tune the receiver hold in the PUSH TO TUNE button and rotate the TUNING control.

(f) Adjust the VOLUME control so that noise is just audible.

(g) Adjust the antenna trimmer (accessible through port hole on left side of receiver) for maximum noise in your headset or loudspeaker. Use a small insulated screwdriver or an insulated hexagonal socket wrench.

(h) Set the ON-OFF switch to OFF.

b. Transmitter. Here's how to check transmitter performance:

(1) Remove the antenna lead from the antenna post on the mounting and connect Antenna A-83 between the TR binding post and the ground screw on the mounting.

(2) Connect either Microphone T-17 or T-33 to the transmitter.

(3) Throw the RECEIVER TUNE-OPERATE switch to OPERATE, and the TUNE-ANT CUR switch to ANT CUR.

(4) Turn the TRANSMITTER switch to ON and see that the pilot lamp lights.

(5) After about three seconds, depress a channel selector push button, and press the microphone switch. The transmitter dynamotor should start and the panel meter should show a deflection or movement. Release the microphone switch.

(6) Repeat step (5) on all remaining channels.

(7) Throw the TUNE-ANT CUR switch to TUNE and note the meter reading for each position of the METER SWITCH. The readings should agree approximately with those given in Table V. (See Paragraph 31e(11) for a detailed discussion.)

(8) Start an associated receiver, plug a Headset HS-30-(*), HS-18, or HS-23 into the receiver PHONES jack, and throw the OUTPUT TO PHONES switch to OFF. Operate the microphone push button and speak into the microphone. The

Table V. Meter Switch Readings*

Switch position	1	2	3	4	5	6
Circuit	Doubler Grid	First R-f Grid	Rectifier Grid	Tripler Grid	Power Amplifier Grid	Total Plate and Screen
Meter reading (27.0 mc)	30	30	20	20	15	65
Meter reading (38.9 mc)	20	25	25	25	15	65

*Transmitter RECEIVER TUNE-OPERATE switch at OPERATE.

speaker's voice should be heard in the headset. The headset volume may be adjusted to the desired level by turning the SIDETONE control on the end of the transmitter.

(9) Press in a channel selector push button on the transmitter, and throw the transmitter RECEIVER TUNE-OPERATE switch to RECEIVER TUNE. The transmitter dynamotor should start when this latter switch is operated.

Caution: Don't run the dynamotor for long periods. It may overheat.

(10) Manually tune the associated receiver to the transmitter channel frequency. Throw the SPEAKER switch to ON.

(11) Operate the microphone switch and speak into the microphone. The speaker's voice should be heard in the receiver loudspeaker at a receiver dial setting within about one-half a channel of the transmitter frequency. Restore the transmitter RECEIVER TUNE-OPERATE switch to OPERATE.

c. Frequency Check on Receiver Dial.

(1) Throw the transmitter and the receiver ON-OFF switches to ON.

(2) Throw the receiver TUNE-OPERATE switch to TUNE.

(3) Throw the SPEAKER switch to ON and turn the VOLUME control to the right.

(4) Throw the SQUELCH switch to ON and set the SENSITIVITY control to minimum.

(5) Latch (depress) corresponding transmitter and receiver push buttons.

(6) Set the transmitter RECEIVER TUNE-

OPERATE switch to RECEIVER TUNE. A beat note should be heard and the receiver dial setting should correspond to the transmitter frequency within one half a dial division.

(7) If a beat note is not obtained hold in the PUSH TO TUNE button and rotate the dial slightly to obtain a beat note.

(8) Repeat steps (5) through (7) for the remaining push buttons, noting all channels upon which note is not obtained.

(9) Reset all receiver and/or transmitter push buttons for channels upon which a beat note is not obtained (see Paragraph 21).

(10) If practical, check settings by establishing communication with another vehicle.

d. System Test. Whenever practicable, check operation of the installation by establishing communication with another radio set.

20. Operation. This paragraph describes procedures for placing the receiver and transmitter in operation, assuming that the push button selectors are adjusted to select the ten desired channels. If it is necessary to change the channels selected by the push buttons of the receiver or transmitter, follow the procedures in Paragraph 21 before operating the equipment.

a. Operation of the Receiver. You may operate the receiver with the SQUELCH switch at either ON or OFF. The squelch circuit controlled by the SQUELCH switch functions to disable the receiver output when no signal is being received; undesirable background noise is thus eliminated during "no-transmission" intervals.

(1) *SQUELCH Switch at OFF.* For loud-

speaker reception, throw the SPEAKER switch to ON, turn the VOLUME control to the extreme right, and throw the TUNE-OPERATE switch to OPERATE. For headset reception, plug the headset into a PHONES jack, throw the SPEAKER switch to OFF, turn the VOLUME control to the extreme left, set the TUNE-OPERATE switch to OPERATE, and the OUTPUT TO PHONES switch to ON.

To start the receiver, throw the REC switch to ON. It takes about 15 seconds for the vacuum tube cathodes to heat. If the receiver controls are set for loudspeaker operation, noise (or possibly a signal) will be heard when the tubes have heated. Regulate the volume with the VOLUME control. If the receiver controls are set for headset operation, and sufficient time has elapsed for the tubes to heat, noise (or a signal) will be heard upon advancing the VOLUME control.

Depress the push button corresponding to the channel upon which reception is desired. The TUNING adjustment is supplementary to the selector push buttons, the selector having previously been set to the desired channels. However, the receiver may be manually tuned to any desired channel by releasing all push buttons (see Paragraph 7) and adjusting the TUNING control while pushing the PUSH TO TUNE button. Tuning is facilitated in this case by throwing the TUNE-OPERATE switch to TUNE and adjusting the TUNING control for a beat note at the transmitter frequency. When the tuning is correct, restore the TUNE-OPERATE switch to OPERATE.

(2) *SQUELCH Switch at ON.* When the SQUELCH switch is at ON, the gain of the receiver may be varied by adjusting the SENSITIVITY control. (With the SQUELCH switch at OFF, the receiver operates at full gain and the SENSITIVITY control is inoperative.) When the squelch circuit is used (SQUELCH switch at ON), adjust the SENSITIVITY control for the highest possible gain without operation of the CALL SIGNAL lamp and loudspeaker (or headset) by radio noise. Incorrect adjustment of the SENSITIVITY control reduces the operating range of the receiver. If there is any doubt about the SENSITIVITY adjustment, throw the SQUELCH switch to OFF. When re-

ceiving weak signals throw the SQUELCH switch to OFF and leave it there. Don't take a chance. If it isn't adjusted on the nose you may miss incoming calls.

For proper adjustment with the SQUELCH switch at ON, set the SENSITIVITY control as far to the right as possible for satisfactory operation. When receiving a weak signal (as evidenced by static with the incoming signal) rotate the SENSITIVITY control carefully to the left until the CALL SIGNAL light just goes out as soon as the incoming signal goes off the air. The SENSITIVITY control setting is correct if the SQUELCH switch may be thrown off and on again without interrupting a weak signal.

b. Operation of the Transmitter. Here's how to put the transmitter in operation:

(1) Set the TUNE-ANT CUR switch to ANT CUR. (Large differences between the meter readings as observed during operation of the transmitter on various channels and the readings noted when the transmitter was tuned up indicate trouble.)

(2) Start the transmitter by throwing the TRANSMITTER switch to ON. Allow about five seconds for the tube filaments to heat.

(3) Plug Microphone T-17 or T-30 into the CARB MIC jack, or Microphone T-33 into the MAGNETIC MIC jack.

Caution: Always make sure a CHANNEL SELECTOR push button is depressed before pressing the microphone switch. Remember this.

(4) Put the transmitter "on the air" by *first* latching the CHANNEL SELECTOR push button corresponding to the desired channel, and *then* pressing the microphone switch.

(5) Turn the TRANSMITTER switch to OFF when finished sending if the stand-by period is likely to exceed three or four minutes. This will prolong tube life.

c. Operation of the Remote Control Unit. For information regarding operation of Remote Control Unit RM-29-D, refer to Technical Manual TM 11-308 furnished with this unit.

THESE PLACES ARE BAD FOR RADIO !

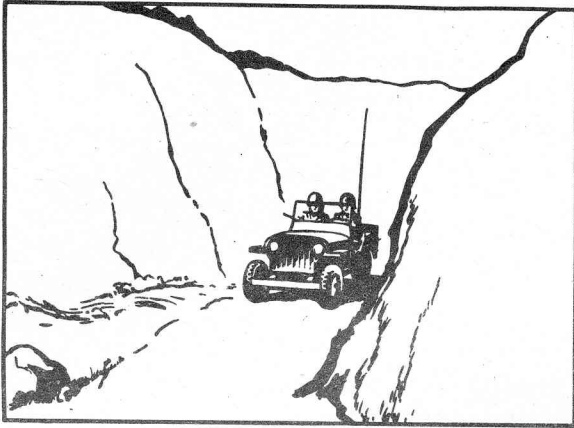

VALLEY

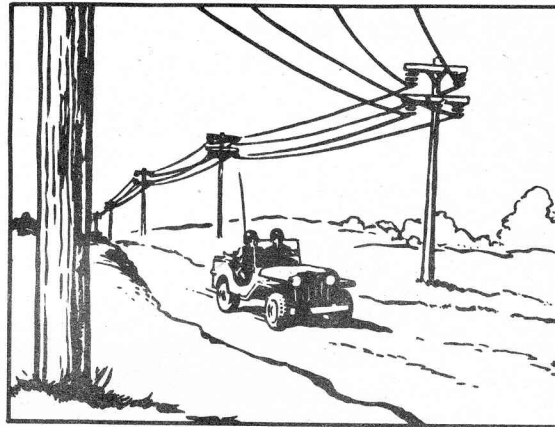

HIGH TENSION LINES

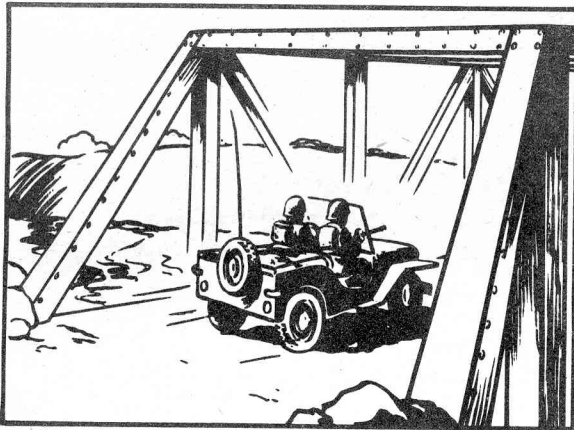

STEEL BRIDGE

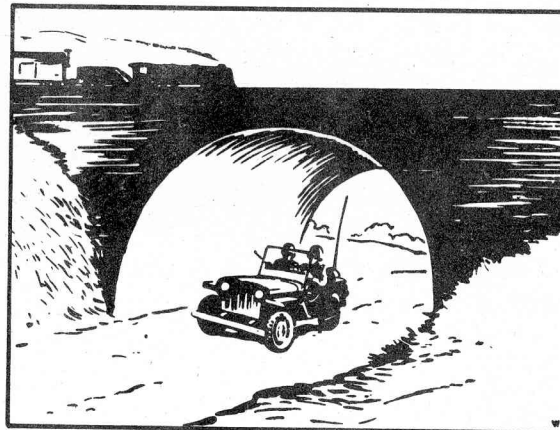

UNDERPASS

THESE PLACES ARE GOOD FOR RADIO !

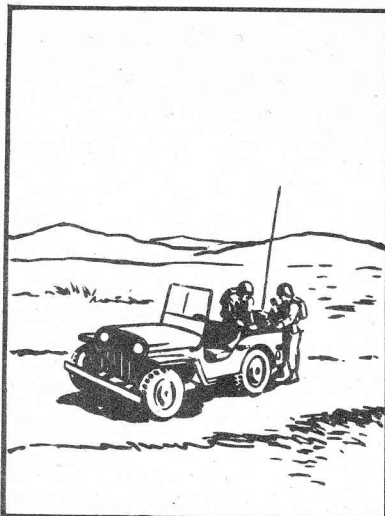

LEVEL GROUND

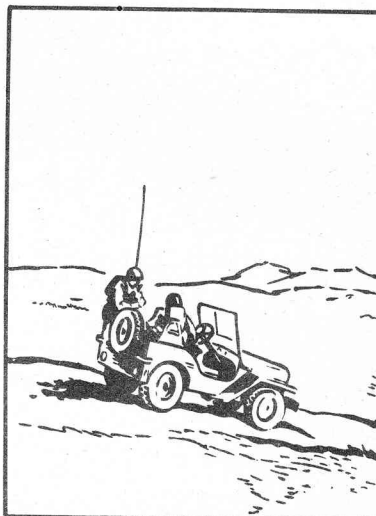

SLIGHT RISE

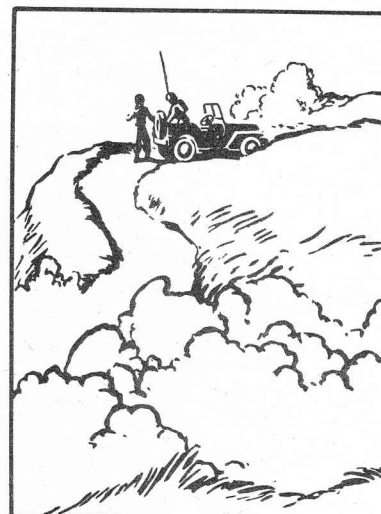

HILL

d. Operating Precautions.

(1) *Transmission Conditions.* The range at which your radio set will work depends on terrain, interference, and radio noise. Under most conditions you should expect 5 to 7 miles *except* in valleys, and under or close to underpasses, overhead steel bridges, and other obstructions which box-in your signals.

Dips, depressions, valleys, and low places are poor for radio transmission and reception. The surrounding higher terrain tends to absorb radio energy.

Good places for sending and receiving are hills, elevations, and slight rises in ground. Flat terrain is also good. But avoid high-tension lines, overhead wires, and locations near electrical machinery which create interference and may blot out even the best of reception. In general, your radio works best in the clear.

You can conceal your vehicle under trees or camouflage, however. Trees and shrubbery won't cut your range. But don't let your aerial rest on



DON'T EXPECT DISTANCE FROM A VALLEY !



DON'T LET YOUR ANTENNA REST AGAINST BRANCHES! THEY'LL CUT YOUR RANGE..

branches or shrubbery when sending or receiving. They will leak off your radio power.

Here's another good operating tip to remember: When you come to the fringe of your operating range—say 10 miles out—static and ignition noise may begin to blot out your reception. If you can do it, try shutting off your vehicle's motor. You'll hear farther. But your battery must be well-charged as your radio draws heavily on it. Keep this in mind if you need a mile or two more range.

(2) *Overheating.* If the entire equipment is mounted in a tightly-enclosed space without enough ventilation, there is danger of overheating after extended periods of operation. Try to operate the equipment for as short intervals as practicable under such conditions.

(3) *Receiver.* Take care when using the squelch circuit and adjusting the SENSITIVITY control. Improper use of these features will result in seriously reducing the range of the set. If there is any doubt whatever about use of the SQUELCH, turn it to OFF and reduce the receiver output

volume sufficiently to prevent fatigue on long stand-by periods but not enough to prevent hearing a signal. Watch this. For weak signals and important incoming calls turn the SQUELCH to OFF and leave it at OFF. Don't take a chance.

(4) *Transmitter.* Always press a CHANNEL SELECTOR push button before starting the dynamotor by operating the microphone control switch or by throwing the RECEIVER TUNE-OPERATE switch to RECEIVER TUNE.

Operation of the transmitter filaments for long periods without application of plate voltage tends to evaporate the active material from their surface and reduce their useful life. Therefore, the TRANSMITTER switch should be at OFF if the transmitter is not to be used for an extended period.

(5) *How to Use Your Microphone.* These radio sets have been designed to work under noisy conditions such as in a tank or other noisy vehicle. To get best results, hold the microphone in a nearly vertical position with your lips just touching the surface. You don't have to shout; but it is necessary to make your voice go into the microphone at a higher level than the surrounding noise. Complete each word before starting the next and put a slight emphasis on all sibilants, such as c, s, and z, and terminal letters, such as t and g. *Speak slowly.* Although the equipment has been designed to reduce as much as possible the effects of the mechanical noise, these instructions will help you obtain satisfactory communication with a remote station, especially under poor receiving conditions. Remember, don't mumble away from your mike. Sound off, directly into it.

21. Presetting Push Buttons. Presetting the push buttons simply means tuning the channels ahead of time to the required frequencies and locking the settings, so from there on tuning may be accomplished by merely depressing the necessary push buttons. This process is exactly that used in a home "push button" radio. It's fast and simple to operate.

a. Presetting the Transmitter. The presetting

procedure is divided into two parts: First—setting the push buttons. Second—tuning the antenna circuit.

(1) *Setting the Push Buttons.* The push buttons may be set with the transmitter in the vehicle or removed. However, if the transmitter is removed a suitable source of d-c power and a Mounting FT-237-(*) or other means of connecting the source of power to the transmitter are required.

(a) Set the ON-OFF switch to ON. *Note.* Allow the transmitter to warm for five minutes before setting the push buttons. Perform steps (b) through (k) while waiting.

(b) Remove receivers. (If the receivers are to be preset also you can save time by leaving the right-hand receiver in position and setting its ON-OFF switch to ON.)

(c) Remove the crystal holders from the crystal compartment and put them in the crystal storage drawer.

(d) Select the required crystal holder for the new frequencies and insert them in the jacks of the crystal holder compartment in the prescribed order. (If no order is prescribed, insert them by numerical order of channel number from top to bottom of the compartment). If desired, write the corresponding channel numbers on the white spaces provided opposite the push buttons.

(e) Replace the crystal holder compartment cover.

(f) Release the push buttons by partially depressing one of them.

(g) Turn the tuning capacitor control (located below the handle on the right end of the transmitter; see Fig. 52), as far as it will go toward the front of the transmitter.

(h) Turn the locking screw (you can reach this with a screwdriver through a small hole located above and to the left of the handle see Fig. 52), to the left until it binds slightly then turn it to the right one-half turn.

(i) Turn the tuning capacitor control all the way to the rear (minimum capacity).

(j) Set the TUNE-ANT CUR switch to TUNE.

(k) Set the METER SWITCH to position 3.

(l) Latch the push button for the frequency to be set. You will find it easier to set the highest frequency (highest channel number) first.

(m) Then, if five minutes have elapsed since the ON-OFF switch was set to ON, start the dynamotor by setting the RECEIVER TUNE-OPERATE switch to RECEIVER TUNE.

Caution: Do not operate the dynamotor any longer than necessary. Always stop the dynamotor when any pause is made in the procedure. Don't let it overheat.

(n) Slowly turn the tuning capacitor control to the right until the panel meter indicates a peak value. Then continue to rotate the control for about one-eighth turn. If two or more peaks are obtained set the control for the highest one.

(o) Set the METER SWITCH to position 1 and carefully readjust the tuning capacitor control for the peak.

Caution: When the METER SWITCH is in position 1, the tuning capacitor adjustment is very critical and the control requires little or no change from the setting that was obtained for the highest peak in step (n).

(p) Stop the transmitter by setting the RECEIVER TUNE-OPERATE switch to OPERATE.

(q) Release the latched push button by slightly depressing an adjacent push button. While doing this step keep your finger on the button being released to prevent it from snapping out with such force as to disturb the setting.

(r) Repeat steps (k) through (q) for the remaining push buttons, preferably going each time from a higher to the next lower frequency channel.

(s) After the last push button is set, carefully release it. (Use two fingers.)

(t) Turn the tuning capacitor control to the maximum front position and tighten the locking screw.

(u) Check each push button setting by turning the METER SWITCH to position 1, depressing the push button, setting the RECEIVER TUNE-OPERATE switch to RECEIVER TUNE, and moving

the tuning capacitor control slightly. If the setting is correct the meter reading should decrease when the tuning capacitor control is moved slightly to *each* side of that position to which it has been set by the push button. Repeat steps (f) through (t) for all settings that are not correct.

(2) *Tuning the Antenna Circuit.* When tuning the antenna circuit use Antenna A-83 to prevent radiation. If Antenna A-83 is not available the transmitter must be in place in the vehicle, the mast antenna must not touch anything, and the vehicle should preferably be located well away from trees, trucks, and other large objects, but *only* to the extent permitted by camouflage requirements.

Caution: Never tune or operate the transmitter without the regular or a suitable artificial antenna (such as Antenna A-83) connected to the antenna post. Large currents developed in the antenna meter circuit with the antenna disconnected would burn out the thermocouple.

(a) Set the TUNE-ANT CUR switch to ANT CUR.

(b) Set the METER SWITCH to position 6. If the meter switch is not set to position 6 sufficient coupling may exist at some frequencies to cause the meter indicator to go off scale.

(c) Latch the push button for the frequency nearest 27 megacycles. (This is the best frequency upon which to tune the antenna for maximum output on the greatest number of frequencies. However, if it is definitely known that maximum output is desired on some particular frequency the coupling can be adjusted on that frequency, but *the coupling should be adjusted for one frequency only.*)

(d) Start the dynamotor with the push-to-talk switch on the microphone (RECEIVER TUNE-OPERATE switch at OPERATE).

(e) Adjust the antenna trimmer capacitor (see Fig. 14) that corresponds to the latched push button for maximum indication on the panel meter.

(f) Adjust the antenna coupling control (see Fig. 14) for maximum indication on the panel meter.

(g) Readjust the antenna trimmer capacitor that corresponds to the latched push button for maximum on the panel meter.

(h) Latch remaining push buttons one at a time and adjust the corresponding antenna trimmer capacitor for maximum on the panel meter. (Do not readjust the coupling control.)

Caution: Do not run the dynamotor any more than necessary.

(i) Make the frequency check outlined in Paragraph 19c.

(j) Remove Antenna A-83 (if used) and connect the mast antenna.

(k) If practical, check settings by establishing communication with another vehicle. (If desired, this check need not be made until after the receiver push buttons have been preset.)

b. Presetting the Receiver. The presetting procedure may be divided into two parts: First—setting the push buttons. Second—tuning the antenna circuit.

(1) *Setting the Push Buttons.* The push buttons may be set with the receiver in the vehicle or removed. However, if the receiver is removed a suitable source of d-c power and a Mounting FT-237-(*) or other means of connecting the source of power is required. An unmodulated signal at the frequency or frequencies to which the receiver is to be tuned must be available. The signal may be from either a remote transmitter or an associated transmitter. The changes necessary to adapt the procedure for use with a remote transmitter are obvious.

(a) Set the transmitter and receiver ON-OFF switches to ON. *Note:* Before setting the receiver push buttons the transmitter should warm up for at least 5 minutes and the receiver at least 15 minutes. If you had left the right-hand receiver in place, and it was warming while the transmitter was being preset, it would not be necessary to wait long. However, you may perform steps (b) to (h) while waiting.

(b) Release the receiver push buttons by partially pressing any one of them.

(c) Press the PUSH-TO-TUNE button and while holding it in, turn the TUNING control

toward the high frequency end of the tuning dial until the word LOCK appears under the hairline.

(d) Insert a screwdriver in the hole above the push buttons and turn the locking screw to the left until it binds slightly; then turn it right one-half turn.

(e) Set the receiver controls as follows:

(1) SPEAKER switch to ON. (You may use a headset instead of the loudspeaker if you wish.)

(2) VOLUME control about two thirds to the right.

(3) SENSITIVITY control to minimum (to the left position).

(4) SQUELCH switch to ON.

(5) TUNE-OPERATE switch to TUNE.

(f) If a second receiver is to be preset, place it in position and make the following settings. (These settings are necessary to eliminate all probability of interference by this receiver.)

(1) ON-OFF switch to ON. (Allow the receiver to warm up.)

(2) SPEAKER switch to OFF.

(3) SENSITIVITY control to minimum.

(4) TUNE-OPERATE switch to OPERATE.

(5) Rotate the dial to its LOCK position.

(6) SQUELCH switch to ON.

(7) OUTPUT TO PHONES switch to OFF.

(g) Latch the transmitter push button for the frequency to be set. (The procedure is made easier if the lowest frequency is set first.)

(h) Then if 15 minutes have elapsed since the ON-OFF switch on the receiver to be preset first was set to ON, turn the transmitter RECEIVER TUNE-OPERATE switch to RECEIVER TUNE.

(i) Hold in the PUSH-TO-TUNE button on the receiver to be preset first and turn the TUNING control until the receiver is tuned to the transmitter frequency as determined by a beat note and the setting of the dial which should correspond to the transmitter frequency. If the setting of the dial does not correspond to the transmitter frequency it is probable that the receiver is tuned to a harmonic or that the transmitter is incorrectly preset.

(j) Hold in the PUSH-TO-TUNE button and latch the receiver push button corresponding to the transmitter frequency.

(k) Slowly release the PUSH-TO-TUNE button while rotating the TUNING control just enough in either direction to maintain approximately zero beat (very low pitched note).

(l) Press the latched push button against its stop two or three times. If the beat note is still very low-pitched depress an adjacent push button slightly and carefully ease the latched push button out. (Use two fingers.)

(m) If the setting is still correct turn the transmitter RECEIVER TUNE-OPERATE switch to OPERATE.

(n) Repeat steps (g) through (m) for the remaining push buttons, preferably each time going from a lower to a higher frequency.

Caution: Always stop the transmitter dynamotor during any pause in the procedure.

(o) After the last push button is set, carefully release it (using two fingers) and rotate the dial to the LOCK position.

(p) Lock the setting by tightening the locking screw. The screw should be firmly tightened but not enough to damage the push-button mechanism.

(q) Make the frequency check outlined in Paragraph 19c.

(r) Set the controls for operation as follows:

(1) TUNE-OPERATE switch to OPERATE.

(2) Adjust the SENSITIVITY control so the CALL SIGNAL lamp just goes out when no signal is being received. (See Paragraph 20a.)

(s) If practical, check settings by establishing communication with another vehicle.

(2) *Tuning the Antenna Circuit.* You must tune the receiver antenna circuit when the set is first installed in the vehicle. Ordinarily it will not require tuning again unless you make some change in the antenna. You can tune it before setting the push buttons if you wish. See Paragraph 19a(2) for the prescribed method of tuning the antenna circuit.

REMEMBER THESE NINE POINTS—

1. Keep your antenna vertical. It sends and receives better that way. Be sure you use the right number of sections.
2. Don't talk away from your mike. Speak directly into it. Sound off!
3. If you want distance, head for the high spots. Watch out for steel bridges, valleys, dips, and low places. Your radio will work, but not so far.
4. Conceal your vehicle but don't let your antenna rest against tree branches when sending or receiving. They will leak off your radio power.
5. Watch out for the SQUELCH switch. For weak signals or important calls, turn it off and leave it off. Play it close to the vest.
6. Don't let your radio sit out in the rain. Try to cover it. Rain may ruin radio equipment in a hurry.
7. Don't install your radio in a tightly inclosed space. Give it air.
8. Don't run your dynamotors unnecessarily long. They get hot and, abused, may burn out.
9. The operation of your set is basically simple. Practice it a few times and it will become second nature.

22. System Operation.

a. *Radio Set SCR-608-A.* Each radio set may transmit on any one of 10 preset channels and receive on any one of 20 preset channels. Two-way communication between two radio sets may be established by use of a single channel or by use of two channels.

The radio set may be used in either of two communications systems: (1) radio communication only, or (2) radio-plus-wire telephone communication. In the first instance the radio equipment needs no auxiliary apparatus other than Microphone T-17, T-30, or T-33 and Headset HS-30-(*), HS-18, or HS-23. In the second instance Remote Control Unit RM-29-D is used to connect a remotely located field Telephone EE-8-(*) to the radio equipment. Figure 23 shows a system block diagram.

(1) *Radio Communication Only.* When the two ends of the radio system (5 to 15 miles apart) have been placed in operating condition, it is necessary only to choose the channel frequency by pressing the proper channel selector button on the respective radio transmitter and radio receiver and press the microphone control switch when transmission is desired.

(2) *Radio-Plus-Wire Telephone Communication.* In this case the twisted pair from the remotely located field Telephone EE-8-(*) is connected to the L1 and L2 binding posts of Remote Control Unit RM-29-D, and Plugs PL-55 and PL-68 of the RECEIVER and MICROPHONE cords, respectively, are inserted into the receiver PHONES and the transmitter CARB MIC jacks. The radio operator's Headset HS-30-(*), HS-18, or HS-23 and Microphone T-17 or T-30

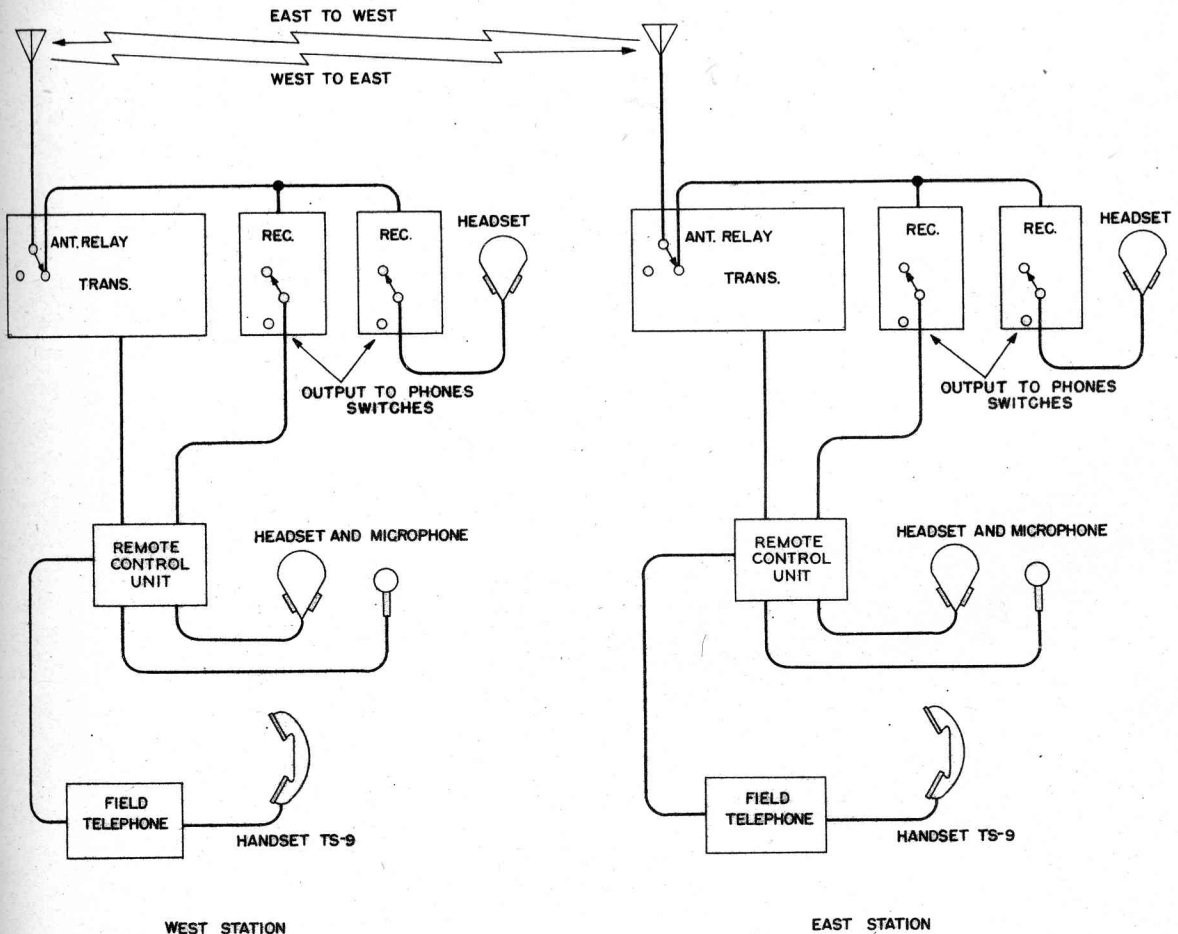

Fig. 23. Radio Set SCR-608-A: System Block Diagram

are plugged into the HEADSET and MICROPHONE jacks on Remote Control Unit RM-29-D. The radio operator may communicate with the field telephone operator by throwing the three-position key to TELEPHONE. The ringing generator and ringer are connected at all times and are operative regardless of the position of the three-position key. When the key is at TELEPHONE, the radio equipment is disconnected from the telephone line and from the radio operator's headset and microphone. When the local operator wishes to communicate with the distant field operator, he may do so by throwing the three-position key to RADIO and pressing the microphone push button while speaking. Operation of the key to the RADIO position disconnects the wire line from the radio equipment and from

the local operator's headset and microphone. When the three-position key is at THROUGH, the field telephone is connected to the radio transmitter and the radio receiver, and the local operator's microphone is rendered inoperative except for the push button switch mounted thereon. The field telephone operator cannot start the radio transmitter when he desires to talk and it is necessary, therefore, for the local operator to monitor all conversations and press and release his microphone push button as required by the two speakers.

b. Radio Set SCR-628-A. This radio set operates exactly like Radio Set SCR-608-A except that it is only possible to receive on 10 channels instead of 20, since there is only one receiver.

WAR DEPARTMENT TECHNICAL MANUAL

TM 11-620

RADIO SETS

SCR-608-A AND SCR-628-A

WAR DEPARTMENT • 1 JANUARY 1944

SECTION III. FUNCTIONING OF PARTS

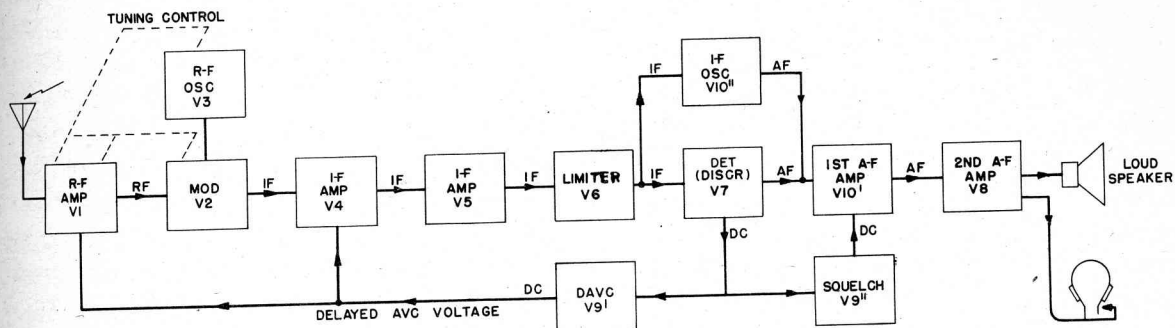

Fig. 24. Radio Receiver BC-683-A: Block Diagram

23. Functioning of Radio Receiver BC-683-A.

a. General Circuits Used. A block diagram of Radio Receiver BC-683-A is shown in Fig. 24.

The receiver employs the superheterodyne principle of operation. The high-frequency circuits include one stage of tuned radio-frequency amplification (V1), a modulator (V2), and a radio-frequency oscillator (V3). The intermediate-frequency amplifier comprises two stages (V4 and V5), the second of which (V5) provides some limiting action on strong signals. The limiter stage (V6) not only functions as a limiter on moderate signals, but it also reduces amplitude modulation. The detector or discriminator (V7) is followed by two stages of audio-frequency amplification (V10' and V8). An intermediate-frequency oscillator (V10'') permits checking the receiver tuning. A single dual-purpose vacuum tube (V9) functions as the first audio stage (V10') and the intermediate-frequency oscillator (V10''). A second dual-purpose tube (V9) provides delayed automatic volume control (V9') and "squench" (V9'') which suppresses noise by disabling the receiver output when no signal is being received.

b. Schematic, Wiring, and Apparatus Location Diagrams. Complete schematic, wiring, and apparatus location diagrams are shown in Figs. 43, 44, 45, 46, 71, and 72. The system schematic, Fig. 69, shows (with some of the minor details omitted) the general arrangement of the control circuits; this drawing will be useful in studying the basic operation of these circuits.

c. R-f Amplifier, Modulator, and R-f Oscillator. Figure 25 is a functional diagram of the radio-frequency amplifier (V1), modulator (V2), and radio-frequency oscillator (V3) circuits.

The antenna is coupled to the input of the radio-frequency amplifier stage by the antenna tuning unit, LCU1A. Current flowing through the primary winding LCU1A induces a voltage across the tuned secondary winding. The voltage thus developed is impressed between the grid and cathode of V1 through by-pass capacitor C35. Decoupling resistor R37, along with this capacitor, prevents interstage coupling through the automatic-volume-control wiring. These by-pass capacitors are needed because the d-c grid return is made to the automatic-volume-control lead instead of to ground. The amplified radio-frequency voltage from V1 is impressed across the tuned primary winding of the interstage tuning unit, LCU2A, through by-pass capacitor C39. Trimmer capacitor C1.1 is used to compensate for variations in the antenna systems of various installations.

Current flowing through the tuned primary winding, L33, induces a voltage across the tuned secondary winding, L34, that is impressed between the grid and the cathode of the modulator tube V2, through by-pass capacitor C3. Capacitors C36 and C38 provide temperature compensation. The bias potential for V2 is determined by the cathode resistor, R3.

The signal frequency, 27.0 to 38.9 megacycles, is converted to the intermediate fre-

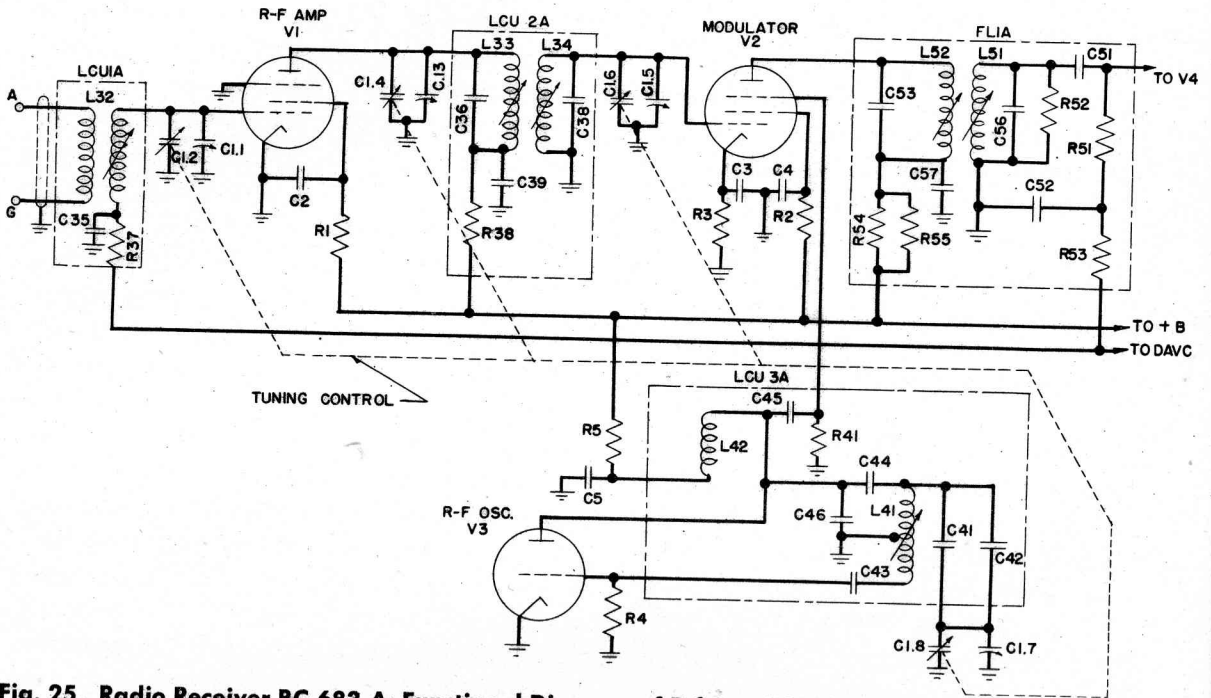

Fig. 25. Radio Receiver BC-683-A: Functional Diagram of R-f Amplifier, Modulator, and R-f Oscillator

quency, 2.65 megacycles, by heterodyning between the signal-frequency voltage and a frequency (2.65 megacycles higher) derived from the radio-frequency oscillator, V3, in the modulator (or mixer) tube, V2. The radio-frequency oscillator voltage is supplied to the suppressor grid of V2. Several modulation frequencies are available in the output of V2; but the first intermediate-frequency filter, FL1A, selects the lower sideband and rejects the undesired frequencies.

The radio-frequency oscillator employs a shunt-fed Hartley circuit. The oscillator embodies three negative coefficient capacitors C42, C44, and C46 in order to compensate for temperature changes and to enable the oscillator to maintain a high degree of frequency stability. Capacitors C41 and C42 are padding capacitors and capacitor C44 is a blocking capacitor. Energy fed back to the grid circuit through coupling capacitor C43 causes the tube to oscillate. Rectified grid current passing through grid leak resistor R4 provides grid bias for V3.

Radio-frequency voltage for the suppressor grid of V2 is derived from the plate circuit of V3 through a coupling capacitor, C45. Resistor R5 and capacitor C5 prevent radio frequency be-

ing fed from the plate of V3 to the plus B lead. L42 is the oscillator plate choke inductor.

Capacitors C1.2, C1.4, C1.6, and C1.8 are ganged to permit simultaneous adjustment of all four tuned circuits. Alignment of the circuits is assured by trimmer capacitors C1.1, C1.3, C1.5, and C1.7 and adjustable iron dust slugs in inductors L32, L33, L34, and L41.

d. I-f Amplifier and Limiter. The essential circuits of the intermediate-frequency amplifier and limiter stages are shown in Fig. 26. Band-pass filters FL1A, FL2A, and FL3A suppress undesired frequencies outside an 80-kilocycle transmission band which is centered at 2.65 megacycles, the intermediate frequency. Each filter is aligned by the adjustment of a magnetic core within each coil. Resistors R52, R62, and R72 in the three filters aid in securing the desired band-pass frequency characteristic.

Intermediate-frequency filter units FL1A, FL2A, FL3A, and FL4 are all provided with temperature compensation in the form of ceramic capacitors with negative temperature coefficients. See Paragraph 43b(10).

The arrangement used in later production is

shown in Fig. 26. Capacitors C53, C56, C63, C66, C73, C76, and C87 are all negative coefficient ceramic capacitors with a nominal capacitance of 60 micromicrofarads. In each case, the capacitor compensates for the positive temperature coefficient of the coil across which it is connected.

The details of the filters used in earlier production are shown in Fig. 70. In this case, the resonating capacitance for the coils was secured by the use of two parallel capacitors: a 50-micro-microfarad molded mica unit and a 10-micro-microfarad ceramic unit. This latter unit was so constructed that its negative coefficient compensated for the positive coefficients of both its associated coil and the mica capacitor.

The first intermediate-frequency amplifier (V4) is subject to delayed-automatic-volume-control action, its grid bias being supplied through decoupling resistors R51 and R53. The remaining potentials applied to the vacuum tube are such as to allow the tube to operate as a conventional amplifier.

The second intermediate-frequency amplifier (V5) differs from the first in the method of grid bias supply and in the relationships between the screen and plate operating potentials. The signal voltage developed across the secondary (L61) in FL2A is applied to the control grid of V5 through coupling capacitor C61. Grid bias is supplied through the decoupling resistor, R63, and the grid leak resistor, R61, from the negative high-voltage lead. The plate decoupling resistor, R74, is returned to the voltage divider at the common function of R21, R28, and R29; the plate voltage, under no-signal conditions, is approximately 60 volts. As a result of this low plate-supply voltage, the output of this stage is limited to a relatively low amplitude, even with a large input from the first intermediate-frequency stage. (Positive peaks are limited by plate saturation conditions; negative peaks are limited, or "clipped," by plate cutoff.)

The screen of V5 is connected to the plate return of the first intermediate-frequency stage (V4) through dropping resistor R8. Under the no-signal condition, the screen potential is approximately 90 volts. This results in a fairly high-

voltage gain on weak signals in spite of the low plate voltage. On strong signals, however, the increased screen current causes a relatively large voltage drop in resistor R8 (70,000 ohms); this reduces the screen potential, thereby reducing the gain. Consequently, the screen circuit serves as a form of automatic gain control.

On strong signals, rectified grid current flowing through R61 and R63 holds a negative charge on capacitor C61. The values of R61, R63, C61, and C63 are such that their time constant is high with respect to the intermediate frequency. As the input signal swings positive in each half cycle, grid current flowing through R61 charges C61. The charge is retained during the negative half cycle because of the high time constant. The negative bias from the rectified grid current flowing through R61 and R63 limits the positive swing on the grid of V5, thus limiting the peak excitation. The negative half-cycle swings are limited by the cutoff of the tube, which has been fixed by the plate voltage selected. The receiver is frequently required to operate with an extremely wide range of signal strengths impressed on the antenna. A peak limiter which is effective on moderate signal strengths tends to overload and fall off in output for very strong signals. To avoid this possibility the peak limiting action mentioned above is provided in the second intermediate-frequency stage to reduce the range over which the limiter stage (V6) is required to function.

The limiter stage (V6) uses two separate types of limiting action: (1) overload (peak) limiting, as just described, and (2) feedback limiting. The fixed grid bias obtained from the voltage drop across R24 is sufficiently large to give a degree of plate detection prior to overload, which is important in feedback limiting.

The overload method establishes a ceiling which the output cannot exceed. On received voltages big enough to reach this ceiling this method keeps the output uniform and thus cuts off disturbances which would tend to increase the output irregularly. It does not, however, have any limiting effect on signals which do not reach this ceiling.

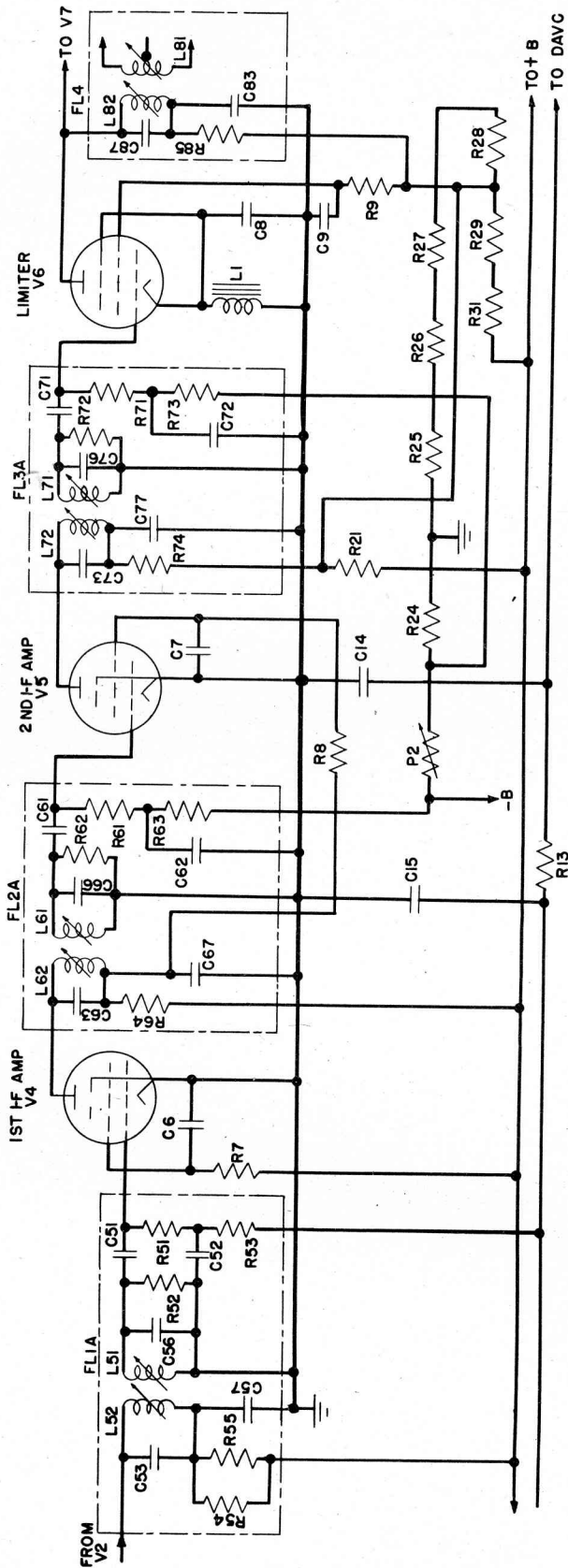

Fig. 26. Radio Receiver BC-683-A: Functional Diagram of I-f Amplifier and Limiter

The feedback method is based on the idea of balancing out a disturbance in the audio-frequency range by means of an equal and opposite impulse. This is very effective on disturbances of an audio-frequency nature which are not large enough to be taken care of by the overload limiter. It is less effective but still helpful in the range between signals strong enough to start partial peak limiting and those of sufficient amplitude to cause complete peak limiting. The negative feedback method operates by means of the coil L1 and the small parallel capacitor C8, presenting a low radio-frequency impedance and a high audio-frequency impedance. Coil L1 is connected in series with the cathode of V6 and low-frequency amplitude variations in the plate circuit flow through this coil. The effect of this current flow is to develop a voltage across the coil between ground and the cathode. This voltage is therefore effectively applied across the grid-cathode circuit of the tube. The voltage developed across the coil and applied to the cathode opposes the effect of the audio-frequency variations in the grid circuit. When the grid voltage increases at an audio-frequency rate due to an increase in the undesired "ripple," the cathode bias will oppose the increase. When it decreases due to a decrease in the ripple, the bias will oppose the decrease. This action tends to smooth out the ripple. Amplitude variations at the carrier frequency will be by-passed by the capacitor C8 and will produce negligible feedback. At frequencies below the audible range the cathode choke L1 represents negligible impedance and does not affect the bias of the tube. For these slower changes the delayed automatic volume control is effective provided the signal is sufficiently large to overcome the delay bias. On the other hand, delayed automatic volume control does not respond to audio-frequency changes in amplitude, due to automatic-volume-control filter circuits.

In this discussion the noise producing disturbance has been considered as a single frequency having a more or less steady value. In practice, however, the disturbance will probably consist of a number of varying frequencies of varying

amplitudes. As long as the disturbing frequencies interact with the carrier to produce frequencies which are in the audio range (and the amplitude is not large enough to reach the ceiling of the peak limiting action), feedback caused by the coil will occur and smoothing of the ripple will be produced.

e. Discriminator. The purpose of the discriminator is to transform the received intermediate-frequency currents (which are frequency-modulated) into amplitude variations at audio frequencies. A functional diagram is shown in Fig. 27a.

The discriminator uses the phase shift between the primary and secondary windings of the intermediate-frequency transformer at the input of V7. Look at the diagram, Fig. 27a; the signal voltage across the primary L82 is shown as E_p . The tapped secondary winding L81 is shown as two windings in series. The induced voltage across these two windings is shown as E_s . Voltage E_s is developed across the capacitors C85 and C86 in series. Since C85 and C86 are very closely matched, their junction is at the same voltage as the midpoint of the secondary tuned circuit of FL4. The voltage across C85 is impressed on one diode (terminals 5 and 8 of V7). The return path is through capacitors C20.3 (which is paralleled by C82), ground, C83, C87 (which is paralleled by C88), and back to the junction of C85 and C86. The other half of the secondary voltage (developed across C86) is impressed on the other diode (terminals 3 and 4 of V7). The return is through C81, C20.3, ground, C83, C87, and back to the junction of C85 and C86.

In addition to these secondary voltages, the primary voltage is also impressed on these two diodes. The junction of C85 and C86 also connects directly to the plate of V6 (the limiter). The primary voltage is developed from this point to ground. Thus, E_p is impressed across a circuit consisting of C85, then the diode (terminals 5 and 8 of V7), then C20.3, to ground. The path through the other side of V7 is through C86, through terminals 3 and 4 of V7, through C81

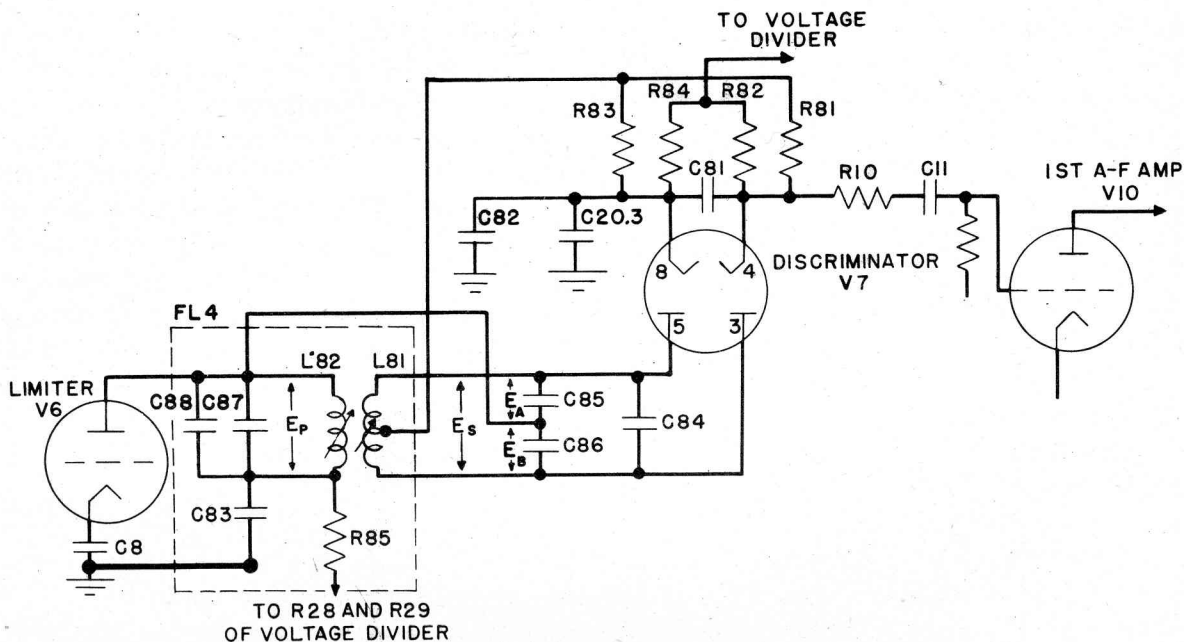

Fig. 27a. Radio Receiver BC-683-A: Functional Diagram of Discriminator

and C20.3, to ground. These are all a-c paths. Since a diode is a tube that is unidirectional, that is, current flows in only one direction, these impressed alternating currents are rectified and this direct current flows through resistors R81 and R83 to the tap at the middle point of L81. This is merely a d-c return.

From this description, it is seen that each diode has impressed on it the primary voltage developed across C87 in series with one half the secondary voltage developed across C85 and C86.

The action of the discriminator depends upon the phase relations between these voltages. At resonant frequency (see Fig. 27b), E_A and E_B are each almost exactly 90 degrees out of phase with the primary voltage E_P . Consequently, W_B , the total voltage across R83, and Y_B , the total voltage across R81, are equal in magnitude; since the rectified voltages appearing across the two resistors are opposite in sign, the resultant d-c voltage is zero. When the impressed signal is either above or below the resonant frequency, however (see Figs. 27c and 27d), the 90-degree phase relationship no longer holds, and the d-c voltages across R83 and R81 no longer balance out. The net result is that the discriminator output voltage follows the variations in frequency

of the incoming signal; the original frequency modulation is translated into amplitude modulation of the discriminator output voltage. This voltage is then impressed upon the grid of the first audio-frequency amplifier tube.

A somewhat more detailed explanation of the discriminator phase relations follows: Consider first the conditions when the output of the intermediate-frequency amplifier and limiter is at the resonant frequency to which both the primary and secondary circuits of FL4 are tuned. This is the case when the signal from the distant transmitter is at the mean or resting carrier frequency (i.e., no modulation is taking place). Voltage E_P (see Fig. 27b) exists across primary winding L82; the primary current, I_P , lags E_P by very nearly 90 degrees; the resulting flux, ϕ , which links the secondary winding is exactly in phase with the current, so it also lags 90 degrees behind the voltage, E_P . Now this flux induces, in secondary winding L81, an electromotive force which drives a current, I_S , through the secondary circuit. (Note that this electromotive force or inducing voltage is *not* E_S , the secondary voltage which would be measured by a voltmeter connected across the secondary winding.) The *induced* electromotive force lags the inducing flux

by 90 degrees; it therefore lags the primary voltage, E_p , by 180 degrees, as shown in Fig. 27b.

As mentioned before, the secondary circuit is resonated exactly to the frequency of the signal; consequently, the impedance which is presented to the induced electromotive force is a pure resistance and the resulting current, I_s , is in phase with the electromotive force, as indicated in Fig. 26b. Now consider voltages E_s , E_A , and E_B . Since secondary winding L81 is a nearly pure inductance, the voltage, E_s , appearing across its terminals will be almost in quadrature (90-degree phase relation) with the current through it. But the two components of E_s , namely, E_A and E_B ,

higher than resonance; the essential phase relations within the discriminator circuit are shown in Fig. 27c. The relations of E_p , I_p , ϕ , and the induced electromotive force in the secondary are as they were in the case of resonance. Now, however, the impedance presented to the induced electromotive force is no longer purely resistive; it has an inductive component and consequently the secondary current lags the electromotive force. Consequently, E_A and E_B are related to E_p as indicated in the figure and the voltages across R83 and R81 (W_C and Y_C , respectively) are no longer equal in magnitude; they do not cancel out.

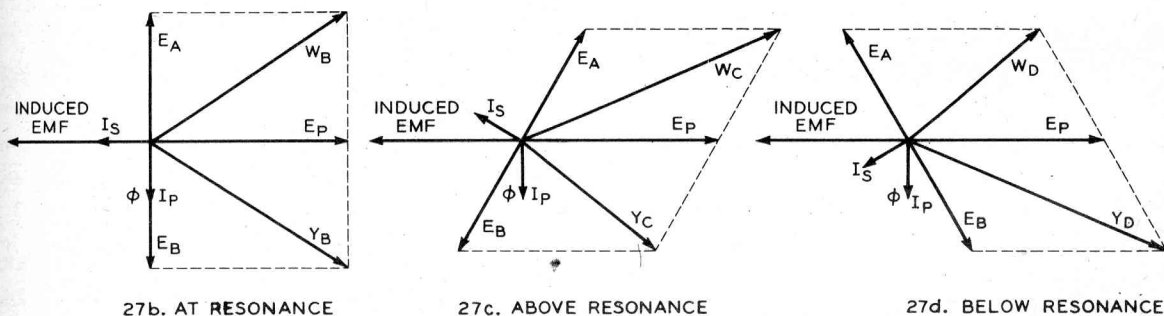

Figs. 27b, 27c, 27d. Radio Receiver BC-683-A: Vector Diagrams Showing Phase Relations in the Discriminator for Variations in Received Frequency

are 180 degrees out of phase with each other (remember that each is measured with respect to the mid-point of the two capacitors, or, what is the equivalent, the center tap of the secondary coil). It follows, then, that one of the two voltages must lead I_s by 90 degrees and the other must lag by 90 degrees, as indicated in Fig. 27b.

As explained previously, the total voltage impressed upon the left-hand diode of V7 is made up of E_p (across C87) in series with E_A (across C85); the total voltage impressed upon the right-hand diode is made up of E_p in series with E_B (across C86). These total voltages are shown in Fig. 27b as W_B and Y_B , respectively. It will be noticed that under the condition assumed (namely, the tuned circuits resonant at the frequency of the impressed signal), the absolute magnitudes, or lengths, of W_B and Y_B are the same.

Now assume that the signal frequency is

When the signal frequency is below resonance the phase relations are as shown in Fig. 27d. The series impedance of the secondary circuit is capacitive and accordingly the secondary current, I_s , leads the induced electromotive force with the result shown. Notice that whereas in the preceding case (frequency above resonance) W_C was greater than Y_C , in this case, Y_D is greater than W_D .

The functions of the various units are described as follows: The tuned circuit comprising L82, C87, and C88 tunes the plate circuit of the limiter tube V6 to the intermediate frequency. The capacitors C83 and C8 in series complete the intermediate-frequency circuit between plate and cathode. C88 provides temperature compensation for C87 and L82. The primary winding, L82, is adjusted for exact resonance at the intermediate frequency by means of an iron dust tuning slug. Plate voltage is applied to the limiter

tube, V6, through the decoupling resistor R85 from the junction of R28 and R29 on the voltage divider. L81 (the tapped secondary), which is coupled to L82, is resonated with capacitors C85, C86, and C84. (C84 is small and provides temperature compensation for the tuned circuit.) This secondary tuned circuit feeds through the double diode V7 to the load resistors R81 and R83 of the discriminator. Capacitor C81, connected across resistors R81 and R83, serves as an intermediate-frequency by-pass and also contributes somewhat to the shaping of the audio-frequency response characteristic. (R82 and R84 are discussed in connection with the automatic-volume-control and squelch circuits; they play no part in the discriminator action.)

One side of the discriminator load circuit is connected to ground through the radio-frequency by-pass capacitor C82 and the audio-frequency by-pass capacitor C20.3 connected in parallel. The other side of the discriminator load circuit connects to the audio-frequency amplifier through series resistor R10 and coupling capacitor C11.

f. Voltage Divider. The voltage divider which is shown in the lower part of Fig. 29 serves three general functions:

(1) It constitutes a bleeder across the high-voltage direct current from the filter to discharge the capacitors when the power supply is not in use.

(2) It provides the reduced positive voltages required by the second intermediate-frequency amplifier, the limiter, the delayed-automatic-volume-control, and the squelch circuits.

(3) It provides negative grid bias for the radio-frequency and intermediate-frequency amplifiers as well as the limiter.

Current flowing from the positive brush of the dynamotor must pass through audio- and radio-frequency choke coils and through R31, R29, R28, R27, R26, R25, R24, and P2 (provided the SQUELCH switch is in the ON position) to the negative brush of the dynamotor. It will be noted that R29 (13,000 ohms) and R31 (6,800 ohms) in series are shunted by R21 (30,000 ohms); this

is, electrically, the equivalent of a single resistor of 12,000 ohms. The combination of three resistors is used, rather than a single 12,000-ohm resistor, because of convenience in mounting and heat dissipation. The junction points between the resistors provide taps giving various voltages which are progressively less positive going from R31 to the junction point of R24 and R25, which point is grounded. (It is useful to bear in mind that neither terminal of the dynamotor is grounded.) The voltage becomes progressively more negative as we go from the ground point through R24 and P2. These two resistors are in the circuit which supplied bias to the grids of the first two amplifier tubes. R24 is fixed but P2 is adjustable. Since an increase in this resistance causes an increase in the voltage developed across it, an adjustment of P2 changes the negative bias applied to the first two amplifying tubes and thus changes the sensitivity of the receiver.

g. A-f Amplifier. A functional diagram of the audio-frequency amplifier is shown in Fig. 28.

The audio-frequency output of the discriminator is developed across the load (R81 and R83 in series) as described in Paragraph 23e. It is connected through the series resistor R10 and series capacitor C11 to the grid of vacuum tube V10'. The other side goes to ground through the radio-frequency by-pass capacitor C82, which has C20.3 shunted across it to reduce the audio-frequency impedance of this part of the ground return. The circuit to the cathode of V10' is through C20.2. Capacitor C13 is shunted from the grid of V10' to ground and shapes the audio-frequency response curve. The resistor R10, in conjunction with C13, is a radio-frequency filter which among other things prevents intermediate-frequency currents from appearing on the grid of V10'. C11 is an audio-coupling capacitor. C26 is part of the intermediate-frequency oscillator circuit. Plate current flowing through cathode resistor R12 serves to bias the grid of V10' when the receiver is operated with the SQUELCH switch at OFF. Since R12 is not by-passed there will be a small amount of negative feedback in the first stage of this audio amplifier which causes some

reduction in the gain of V10'. (Negative feedback is incorporated in this circuit not primarily to reduce distortion but rather to reduce the gain of V10', the full amplification of which is not required for this application.) Grid return is completed through the grid leak R11 and the squelch circuit resistor, R17, to one side of R12.

The function of R17 is described in Paragraph 23*i*. A portion of the SQUELCH switch D4 con-

sufficient to extinguish the CALL SIGNAL lamp. At very high signal levels, which normally cause overloading, the lamp may be extinguished over part of the cycle due to that overload. This condition results in some distortion which is not usually objectionable.

The plate of V10' is connected through the coupling capacitor C21 to one side of the volume control P1, the wiper of this control being con-

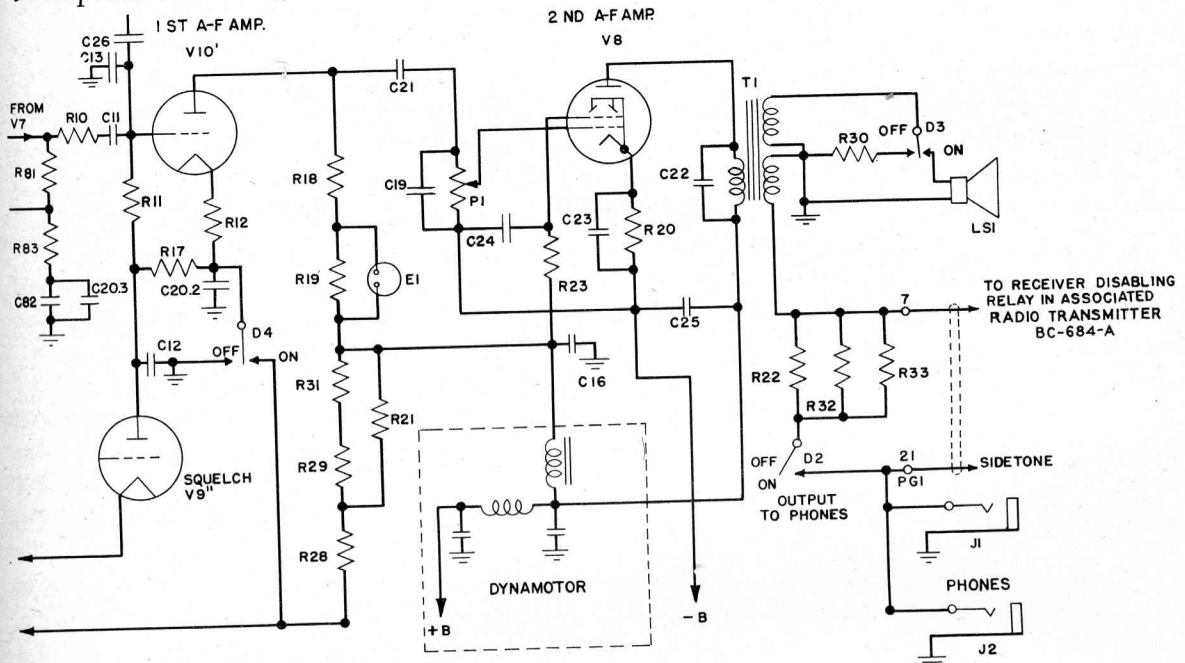

Fig. 28. Radio Receiver BC-683-A: Functional Diagram of A-f Amplifier

nects the junction of R12 and R17 to ground when the SQUELCH switch is at OFF (removing any additional bias that might be developed across R17 by the squelch circuit). The plate circuit of V10' connects through R18 and R19 to the B supply voltage, which is by-passed to ground by C16. The 2-megohm resistor R19 is shunted by the CALL SIGNAL lamp E1, a neon lamp which has an impedance of about 200,000 ohms when normal lighting current is passing through it. When a signal is received the plate current flows and develops a voltage across R19, which increases up to the breakdown potential of the lamp. The lamp then breaks down, greatly reducing the impedance in series with the plate and lighting the lamp. At normal signal levels, the plate current variations of V10' are not

connected directly to the control grid of the second audio amplifier (beam power). V8. The grid circuit of V8 is completed from the other side of the volume control P1 to the minus B lead. A high-capacity electrolytic capacitor, C23, prevents audio-frequency feedback across the cathode bias resistor R20, which connects to the minus B lead. Capacitor C19 is connected across P1 to reduce further the higher audio frequencies, and to prevent the possibility of pickup of unwanted intermediate-frequency currents which might otherwise be amplified by V8.

The value of C21 as well as the value of C11 previously referred to were chosen to reduce the gain of the audio amplifier at frequencies below 400 cycles.

The screen grid supply for V8 is obtained

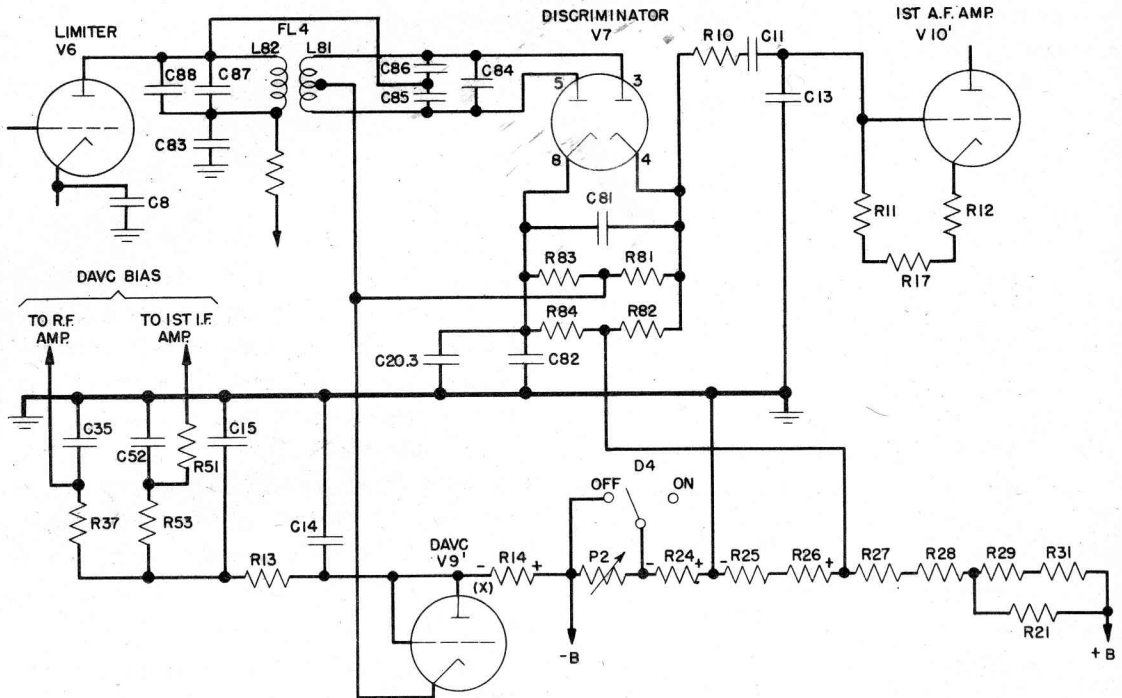

Fig. 29. Radio Receiver BC-683-A: Functional Diagram of Delayed-automatic-volume-control Circuit

through the series resistor R23 from the plate power-supply circuit. Capacitor C24 is the screen by-pass capacitor. The plate circuit of V8 is connected through the primary winding of the output transformer T1 to the power supply which is by-passed at this point by capacitor C25 to complete the return circuit to the minus B lead.

Capacitor C22, connected across the primary winding of the output transformer T1, serves to reduce the higher audio frequencies. It also serves to reduce transient voltages that may be developed in the plate circuit of V8 under overload conditions, which would tend to drive the grid voltage beyond cutoff. The bias for V8 is developed by plate current flowing through the cathode resistor R20. One of the secondary windings of the output transformer T1 may be connected through the speaker switch D3 to the loudspeaker. With switch D3 at OFF, resistor R30 is connected across this winding to prevent changes in headset level taking place when the loudspeaker is turned on and off. Resistor R30 also provides a constant load on the output of V8, further reducing effects of transient voltage.

The remaining winding of the output trans-

former T1 connects through the parallel resistors R22, R32, and R33 to the OUTPUT TO PHONES switch D2. This switch connects in turn to the PHONES jacks J1 and J2. (A parallel connection is provided from these jacks to terminal 21 of the plug PG1.) The return circuit to this winding is completed through ground from J1 and J2. The series resistors R22, R32, and R33 in this circuit prevent the sidetone circuit (which is also connected to the PHONES jacks J1 and J2 through terminal 21 of PG1) from being short-circuited by the disabling relay in the transmitter. The disabling relay in the associated transmitter functions during periods of transmission to short-circuit this latter winding of T1.

When background noise is high, particularly at the point of transmission, the operator should make sure to talk directly into his microphone in a loud tone of voice in order to override local noise. This will increase the volume of the receiver output considerably. Under actual service conditions the overloading due to loud talking does not reduce the degree of intelligibility very much, but the decreased volume caused by failure to talk loudly and directly into the micro-

phone will often result in poor reception of your signals.

b. Delayed-automatic-volume-control Circuit. A functional diagram of the delayed-automatic-volume-control circuit is shown in Fig. 29.

As already mentioned it is very important that the signals reaching the discriminator be of uniform amplitude. In order to accomplish this, peak limiting is provided in the second intermediate-frequency amplifier (V5) and both peak limiting and feedback limiting are provided in the limiter stage (V6). In addition, the automatic volume control is used to take care of the variations below the audio-frequency range which are too slow to be handled by the feedback limiter and too small for the overload limiter. The detailed circuit arrangements will be described following a discussion of the general method by which the delayed-automatic-volume-control arrangement functions.

Since this is *delayed* automatic volume control, there must be a delay bias. This is provided by connecting the plate of the delayed-automatic-volume-control tube V9' to a point which is negative with respect to the cathode connection. This fixed bias prevents plate current from flowing in V9' when there is no output from the limiter V6. This fixed bias is the sum of the voltages across P2, R24, R25, and R26.

When there is output from the limiter, the intermediate-frequency voltage developed across FL4 is impressed across the plate and cathode of V9' (as described in more detail later). When this is sufficient in magnitude to overcome the fixed bias on V9', plate current will flow in that tube during part of each half cycle. This plate current flows through a high resistor (R14) which is in the common grid return of the radio-frequency and first intermediate-frequency amplifier tubes (V1 and V4). This causes a voltage to be developed in that resistance, thus increasing the negative bias applied to the grids of those amplifier tubes.

It will be noted that the cathode circuit of V9' includes R81 and R83 which form the discriminator load resistor. Direct current flowing through these resistors due to discriminator ac-

tion makes their junction negative with respect to the outer ends of the combination. Since the negative end of this developed voltage is toward the cathode of V9', this effect tends to reduce the delay bias materially as the signal strength increases.

In addition, intermediate-frequency current flowing through resistors R81 and R83 (from the plate of V6 through C85, C86, and tuned circuit of L81, returning to the cathode of V6 through C81, C82, and C8) causes an intermediate-frequency voltage to be applied directly to the cathode of V9'. This intermediate-frequency voltage is rectified when the peaks exceed the reduced delay bias. It will be noted that since this rectified current divides equally through the discriminator load resistors, it does not affect the audio-frequency discriminator output.

The net result of these factors is that the automatic-volume-control tube, V9', is biased so that no plate current flows in it until the output of the limiter V6 exceeds a certain amplitude. When that occurs, this intermediate-frequency voltage (which is applied to both the discriminator and the automatic-volume-control tube) undergoes half-wave rectification in V9' and causes pulsating plate current in that tube. This plate current develops a d-c voltage in R14 which is effectively in series with the fixed bias applied to the radio-frequency and first intermediate-frequency amplifiers (V1 and V4). This rectified d-c voltage component progressively increases the negative bias applied to V1 and V4, decreasing the amplification of these tubes, thus tending to maintain a constant output from the limiter.

The circuit arrangements for providing the automatic-volume-control actions are described in more detail as follows (referring again to Fig. 29): The cathode of the automatic-volume-control diode V9' is connected through R81 and R82 in parallel with R83 and R84 to the junction of R26 and R27 on the voltage divider, then through resistors R25 and R26, to ground. The plate and grid are both connected through R14 to the negative end of the dynamotor; thus they are negative with respect to the cathode when

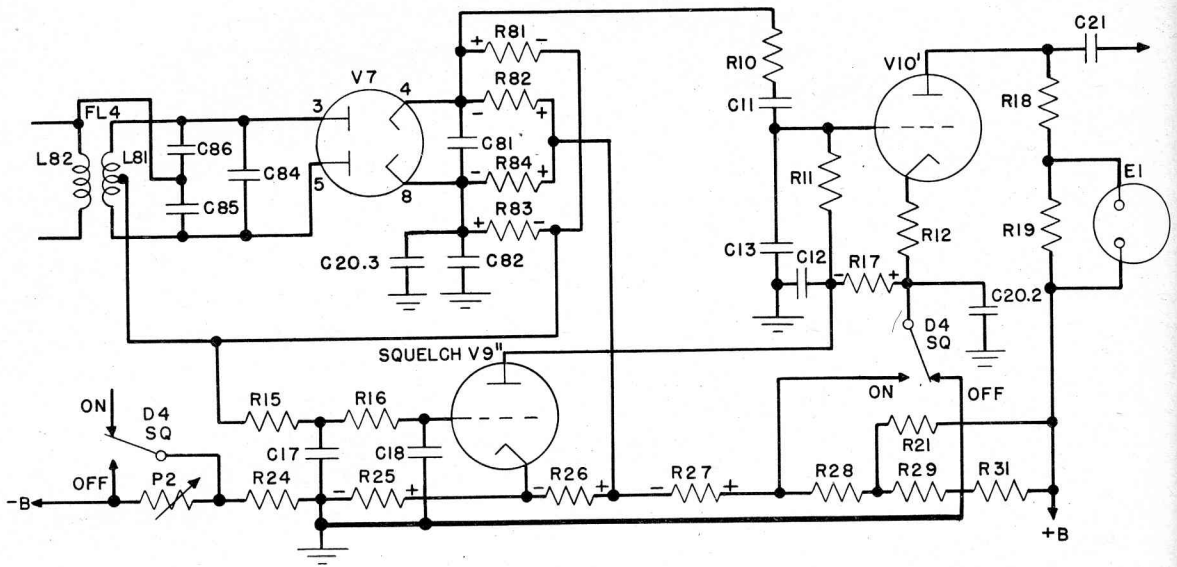

Fig. 30. Radio Receiver BC-683-A: Functional Diagram of Squelch Circuit

no signal is being received. This rectifier circuit is completed to ground through R14 (P2 when the SQUELCH switch is at ON), and R24. These resistors are also in the circuit which provides bias to the first radio-frequency and first intermediate-frequency amplifying tubes, V1 and V4.

The intermediate-frequency voltage developed across FL4 appears between the plate of V6 and ground. The plate of V6 is connected directly to the junction of C85 and C86. As far as relation to ground potential is concerned, this junction is equivalent to the midpoint of L81 which is connected directly to the cathode of V9'. Thus the cathode of V9' is connected effectively to the plate of V6. The return circuit from the plate of V9 is through C14. The intermediate-frequency voltage is thus impressed across the rectifier V9'. When the amplitude is sufficient, half-wave rectification occurs, which causes plate current to flow through R14. This causes the point (x) to become increasingly negative as the output of V6 increases. Since the potential of point (x) determines the bias applied to V1 and V4 (radio-frequency and first intermediate-frequency amplifiers), it is apparent that increasing the input to the receiver causes a decrease in the gain and thus tends to keep the output of V6 constant.

Currents reaching the discriminator cause d-c

voltages across R81 and R83, by discriminator action. The junction of these two resistors is the negative end of each. R82 and R84 are connected in such a way that R81 and R82 are effectively in parallel with R83 and R84 for this application, and the negative end of the voltage developed across this combination is connected to the cathode of V9'. This voltage is not large enough to overcome the fixed bias but reduces it materially. R82 and R84 are provided to permit introducing the fixed bias on V9' without affecting discriminator action and also without short-circuiting the audio-frequency output across R81 and R83.

The grid bias lead for V1 and V4 is supplied through resistor R13 with capacitors C14 and C15 connected to ground at its two ends to prevent radio- and audio-frequency feedback to the grid of these tubes. V1 and V4 also have individual filter resistors R37 and R53 respectively, between the grid and the common grid bias supply. Each of these two tubes has an individual radio-frequency by-pass capacitor connected from the grid end of its filter resistor to ground.

i. Squelch Circuit. A functional diagram of the squelch circuit is shown in Fig. 30.

The squelch circuit is designed to disable the receiver output when the desired carrier is not received. In this manner, hiss and undesirable

background noise (normally present under a no-signal condition) are eliminated in the "no-transmission" intervals. In order to accomplish this more efficiently over a wide range of possible signal and background levels, a sensitivity control is provided. This is effective only when the squelch circuit is turned on, and normally enables the operator to adjust the threshold level (operating point) of the squelch circuit in such a way that the average background interference alone will not maintain the receiver in operating condition. Desired signals, however, not only will cause the set to become operative but also will light the CALL SIGNAL lamp.

The operation of the squelch circuit is accomplished by having plate current flow in the squelch tube V9'' when no carrier is being received. This plate current in V9'' flowing through resistor (R17) produces a d-c voltage which is applied as negative bias to the first audio-frequency amplifier V10'. This bias is sufficient to prevent any signal transmission beyond that point. Thus there is no receiver output. When carrier voltage is received, the current flowing through resistors R81 and R83 from discriminator action sets up a d-c potential which is applied to the grid of the squelch tube V9'' to prevent the flow of plate current. Thus the bias caused by that plate current is removed from the grid of V10' and the audio amplifier operates normally. The following discussion shows in more detail how this is accomplished:

When there is no input to the discriminator, no signal voltage will be built up across either R81 or R83. With no signal voltage being received, noise voltage is developed across R81 and R83. If the SQUELCH switch is at ON, the amount of noise voltage is adjustable by means of P2, and the audio-frequency amplifier V10' (Fig. 30) is then biased beyond cutoff by reason of the current (from the plate circuit of the squelch tube V9'') flowing through R17. The CALL SIGNAL light is then extinguished since no current flows in the plate circuit of V10'. It will be observed that the control grid of the squelch tube is positive with respect to the cathode (grid current flow is limited by R15 and R16). The cathode is connected to the junction of R25 and

R26 while the grid is eventually returned to the junction of R26 and R27. This return path is through resistors R15 and R16, then through R81 and R82 in parallel with R83 and R84, to the voltage divider. Also the plate is returned through R17 and the switch D4 (at ON) to the junction of R27 and R28 which is positive with respect to both the cathode and the grid. Therefore, plate current flows in the squelch tube V9'' and through resistor R17 to produce a voltage drop through R17. The negative end of this voltage drop is at the junction with R11 and thus applies negative bias through R11 to the grid of the first audio-frequency amplifier V10'. This voltage is sufficient to bias V10' below cutoff; hence, no plate current flows and the amplifier is "disabled." The by-pass capacitors C17 and C18 are connected to ground from either side of R16, to prevent intermediate-frequency or audio-frequency currents from flowing through R15 and R16 and actuating the squelch tube, since operation of this circuit is controlled mainly by the d-c component of the rectified input signal. Capacitor C12 serves to filter the plate circuit of V9'' in a similar way. Capacitor C20.2 provides an audio-frequency return path to ground from the cathode circuit of the first audio-frequency stage.

When a signal is being received, a voltage of intermediate frequency is developed across the tapped secondary L81 of filter unit FL4. This is applied to the two diodes of the discriminator V7. In one case a resulting electron flow occurs from the cathode (4) to the plate (3), through L81 (upper winding), R81, and back to the cathode. The other circuit is from the cathode (8) to the plate (5), through L81 (lower winding), R83, and back to the cathode. The voltages built up across R83 and R81 are such that the negative terminal of each is at the junction of the two resistors. For bias purposes, these two voltages are effectively connected in parallel by connecting two high resistors, R84 and R82, from the positive terminals of R81 and R83. The other ends of both R82 and R84 are then connected to the junction of R26 and R27 on the voltage divider.

The negative end of this potential effectively

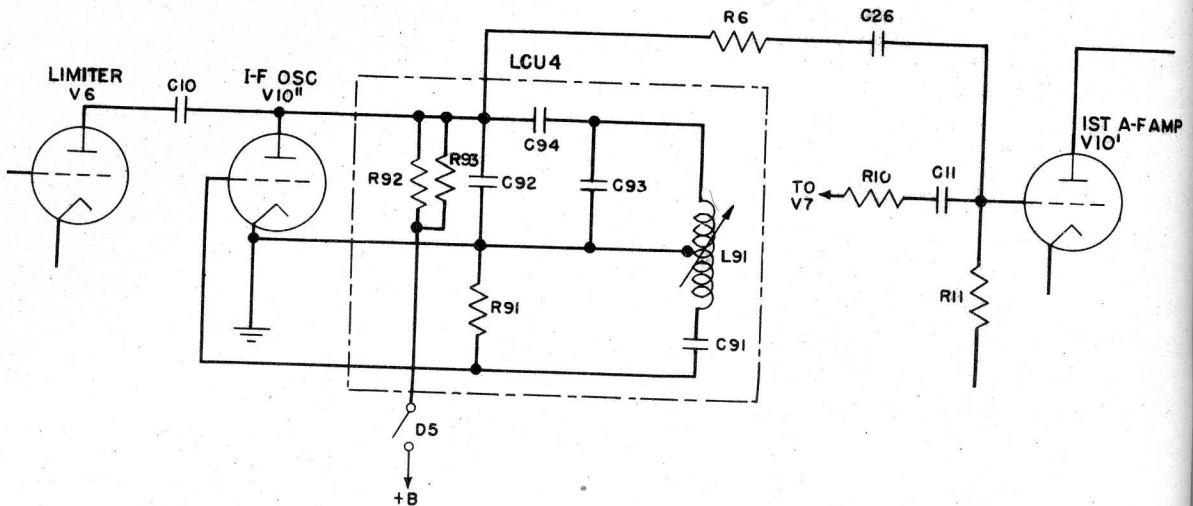

Fig. 31. Radio Receiver BC-683-A: Functional Diagram of I-f Oscillator

developed across R81 and R83 in parallel is applied through resistors R15 and R16 to the grid of the squelch tube V9''. It will be noted that this potential is in opposition to the grid bias (the voltage drop across R26 and R27) which is applied to V9'' whenever the SQUELCH switch is at ON. When no input exists at the discriminator, plate current will flow in V9''. When a signal is being received, however, the voltage developed across resistors R81 and R83 is sufficient to overcome the fixed bias and stop the flow of plate current in V9''; thus the effect of the squelch is eliminated and the audio-frequency amplifier will function normally.

The SENSITIVITY control is described as part of the voltage divider. It regulates the radio-frequency gain of the receiver to make it as high as possible without providing enough average noise voltage to "trip" the squelch tube.

j. I-f Oscillator. A functional diagram of the intermediate-frequency oscillator is shown in Fig. 31.

The intermediate-frequency oscillator employs a Hartley circuit which is quite similar to the radio-frequency oscillator of the receiver. Coil L91 is adjustable to permit tuning to 2.65 megacycles. Capacitor C93 provides the bulk of the tuning capacitance. Capacitor C92 provides temperature compensation and C94 is a blocking

capacitor. Capacitor C91 provides feedback and resistor R91 provides grid bias.

The intermediate-frequency oscillator operates as an autodyne detector. Some intermediate-frequency energy from limiter V6 is impressed upon the plate of the oscillator through a small coupling capacitor, C10. This energy modulates the oscillator, and the audio-frequency beat note produced is passed on to the first audio-frequency amplifier through R6 and C26. C26 is a coupling capacitor. R6 prevents a short circuit of the audio amplifier. The coupling capacitor C10 is small enough to prevent audio frequencies from appearing on the plate of the limiter. The oscillator is controlled by the TUNE-OPERATE switch, D5, which supplies plate voltage to V10'' through the load resistors R92 and R93.

k. Vacuum Tube Heater Circuits. A functional diagram of the vacuum tube heater circuits in the receiver is shown in Fig. 32.

These circuits are permanently grounded to the receiver chassis at three points, i.e., terminal 2 of V1, terminal 7 of V4, and terminal 2 of V3. Terminal 1 of plug PG2 is grounded also. When the dynamotor is installed in the receiver, the strap connections shown (which are included in the base of the dynamotor) modify the circuit as required for operation at the battery voltage indicated on the dynamotor. Thus, if 24-volt bat-

tery operation with Dynamotor DM-36-(*) is assumed, J801 of the dynamotor connects terminal 3 on plug PG2 to terminal 2; and the 24-volt battery is impressed across three parallel circuits (of series heaters) to ground: (V9, V7, V10, and V3), (V5 and V4), and (V8, V6, V2, and V1). If 12-volt battery operation with Dynamotor DM-34-(*) is assumed, J701 of the dynamotor connects terminal 3 on PG2 to terminals 12, 9, and 15 and straps terminal 1 to terminal 2. By these connections, the 12-volt battery is impressed across six combinations of

accomplish a similar function on the high-voltage end. L701 together with C25 constitutes an audio filter to remove the audio-frequency ripple which exists at the output of the dynamotor.

For Dynamotor DM-36-(*), the corresponding components in the 800 series perform similar functions.

24. Functioning of Radio Transmitter BC-684-A.

a. Block Diagram. A block diagram of the transmitter is shown in Fig. 33.

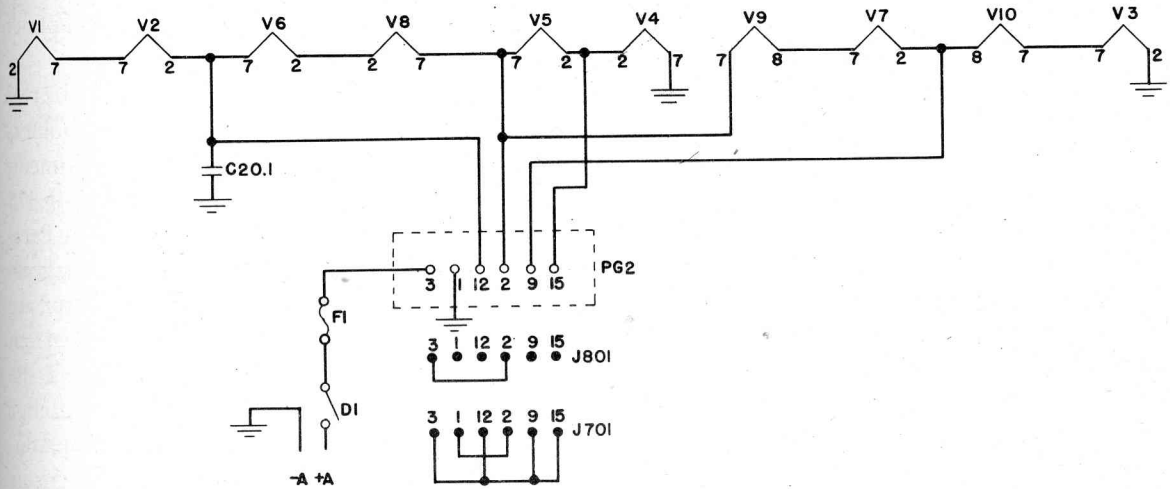

Fig. 32. Radio Receiver BC-683-A: Functional Diagram of the Heater Circuits

heaters to ground: (V2 and V1), (V6 and V8), (V10 and V3), (V7 and V9), (V4), and (V5).

As mentioned in Paragraph 7b, a 12-volt dynamotor must be used with a 12-volt battery and a 24-volt dynamotor with a 24-volt battery. The connections within a dynamotor are so arranged that the circuit is automatically changed to adapt it to the battery voltage.

1. Dynamotor Filter Circuits. Filter circuits are provided in both the low- and the high-voltage sides of the dynamotors to overcome interference caused by the commutator as well as to provide the required degree of filtering. In the case of Dynamotor DM-34-(*), capacitors C703 and C704 together with L702 constitute a low-voltage filter to prevent commutator interference from the low-voltage end. C701, C702, C705, and C706 together with L703 and L704

The gang-tuning control, operated by the push button selector, selects any one of ten preselected crystals and connects it to the oscillator (V107). The oscillator output frequency (f_x) is amplified by the first radio-frequency amplifier (V101) and, along with the audio-frequency signals, is impressed upon a saturated iron-core modulation coil (MOD COIL).

The output of the modulation coil is rich in harmonics of the crystal frequency. After rectification by V102, the reason for which will be given later, the *twelfth* harmonic of the crystal frequency ($12 f_x$) is selected and impressed upon a frequency tripler (V108). The tripler output ($36 f_x$) excites a frequency doubler (V103). The doubler output ($72 f_x$) drives the power amplifier (V104) at the carrier frequency ($f_c = 72 f_x$). The proper one of ten pretuned an-

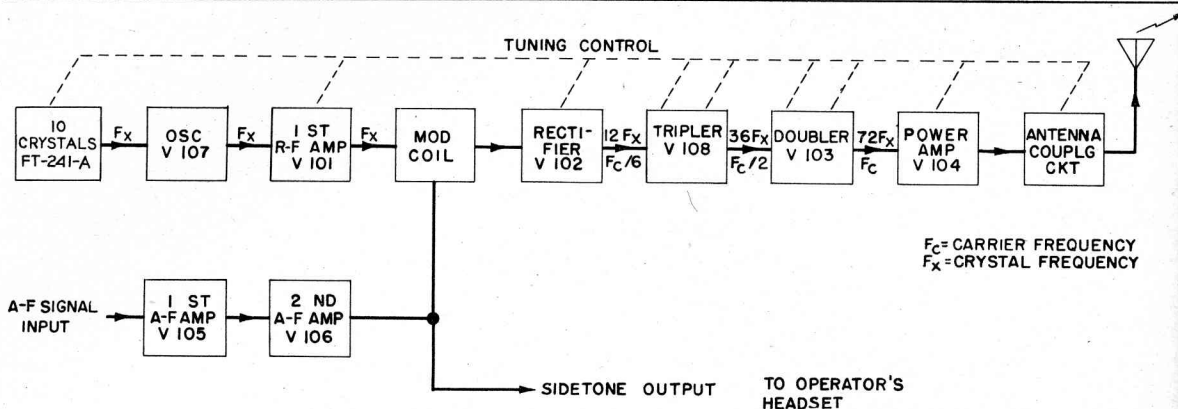

Fig. 33. Radio Transmitter BC-684-A: Block Diagram

antenna coupling circuits is selected by the gang-tuning control and connected to the antenna.

Speech signals from a microphone associated with the transmitter are amplified by a two-stage audio-frequency amplifier (V105 and V106).

A small amount of audio output from V106 is caused to pass through the headset circuit. This is called "sidetone." It enables the commander to hear all that goes out from his radio transmitter and prevents confusion where two people have microphones for the same transmitting set. Also, when the operator's ears are covered by a headset he does not have the normal sensation of hearing himself talk unless sidetone is provided.

b. Schematic, Wiring, and Apparatus Location Diagrams. Complete schematic, wiring, and apparatus location diagrams are given in Figs. 47-50, 74, and 75.

c. Crystal Oscillator and First R-f Amplifier. A functional diagram of the crystal oscillator

(V107) and the first radio-frequency amplifier (V101) is shown in Fig. 34.

The frequency of the oscillator (V107) is controlled by any one of ten crystals in Holders FT-241-A placed in the crystal compartment. The crystal frequencies are in the range of 375 to 540 kilocycles, as listed accurately in Paragraph 3d, Table II. In the functional diagram the important components of the oscillator are the crystal, Y101 to Y110, capacitor C151 from the control grid of V107 to ground, and the tuned circuit C105-L102 in series with capacitor C104. The crystal is connected between the control grid and the junction of the tuned circuit and C104. The remaining components provide the proper screen grid and plate potentials, grid bias, and a high-frequency impedance (L117-R149).

The oscillator operates as a modified "grid-ground" oscillator in which the crystal is above ground because of the impedance of capacitor C104. The phase of the current through this

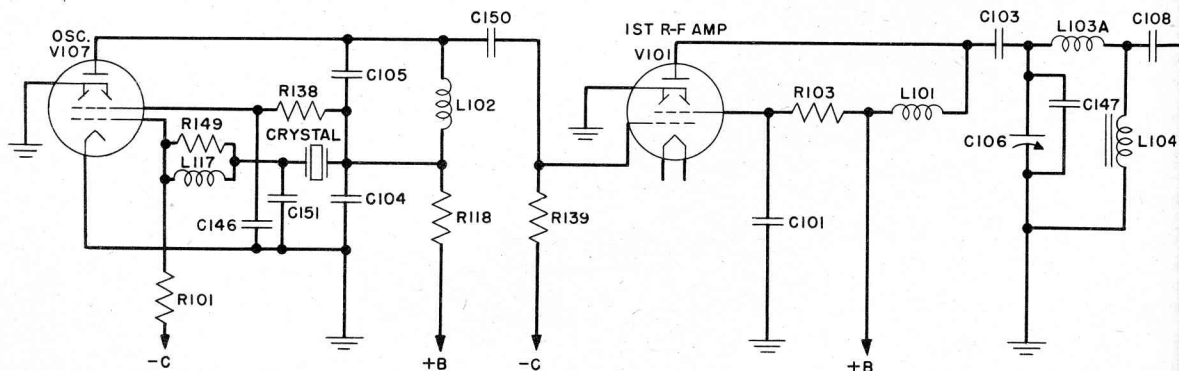

Fig. 34. Radio Transmitter BC-684-A: Functional Diagram of Oscillator and First R-f Oscillator

capacitor is such that some additional feedback is obtained, over that occurring in the usual grid-ground circuit. This causes more rapid crystal starting and increases the output.

The parallel-connected inductor and capacitor in the plate circuit of the oscillator, L102 and C105, are proportioned to increase the excitation on the grid of V101 at the higher frequencies over that which would be obtained otherwise. Capacitor C150 prevents the oscillator plate d-c voltage from appearing on the grid of V101.

Grid bias for the first radio-frequency amplifier V101 flows through resistor R139. The screen of V101 is kept at radio-frequency ground potential by by-pass capacitor C101. The d-c supply for the screen is obtained from the 400-

audio signal (output of the second audio-frequency amplifier, V106).

The radio-frequency input derived from the first radio-frequency amplifier causes a current of about 0.3 ampere to flow through parallel-resonant circuit L103A, L104, C106, and C147. L104 becomes magnetically saturated at a much lower current than this. When the instantaneous radio-frequency current exceeds the saturation value there is no appreciable increase of flux density and the inductance of the coil drops to a low value. Consequently very little voltage appears across it when the instantaneous current through it is higher than the saturation value.

Between the saturation value and zero current, the coil has a high inductance, and a change

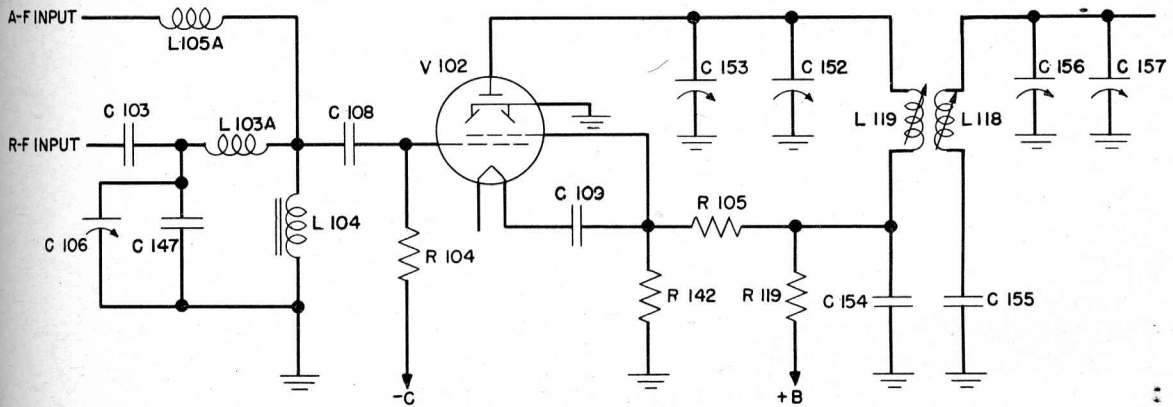

Fig. 35. Radio Transmitter BC-684-A: Functional Diagram of Modulator and Rectifier

volt supply through resistor R103. The plate circuit is fed through radio-frequency choke coil L101, and the load circuit (L103A, L104, and C106), is isolated by blocking capacitor C103.

d. Modulator and Rectifier. A functional diagram of the modulator and rectifier stages is given in Fig. 35.

Two important functions are performed by inductor L104, which is a small nonlinear coil specially designed for use in this transmitter. The coil, together with its associated tuning inductor and capacitors (L103A, C106, C147), serves as a harmonic producer; at the same time, it functions as a modulating element which causes the carrier-frequency output of the first radio-frequency amplifier to be phase-modulated in conformity with amplitude variations of the

in current causes a relatively large change of flux density. Under this condition (that is, when the current passes through the *magnetization range* of the coil) there is a large change in the magnetic field; a high counter-voltage is induced across the coil. The current through L104, therefore, produces sharp voltage peaks each half cycle as the radio-frequency current wave passes through zero. The voltage peaks alternate in polarity each half cycle and are evenly spaced in time. The peaks have a distorted wave shape and contain many harmonics of the original (crystal) frequency.

Figure 36 shows how phase modulation may be produced by passing combined carrier and signal currents through L104. Figure 36a represents the current through L104 (crystal fre-

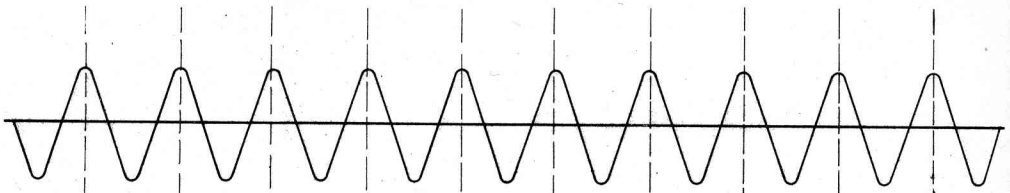

FIG. 36a - CARRIER CURRENT

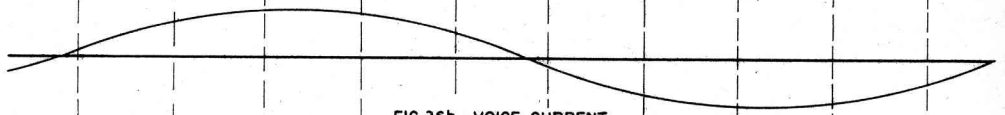

FIG. 36b - VOICE CURRENT

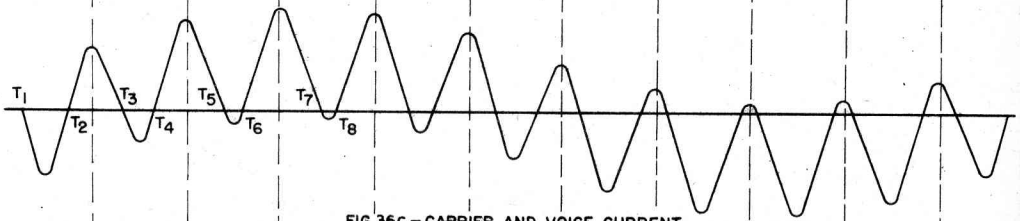

FIG. 36c - CARRIER AND VOICE CURRENT

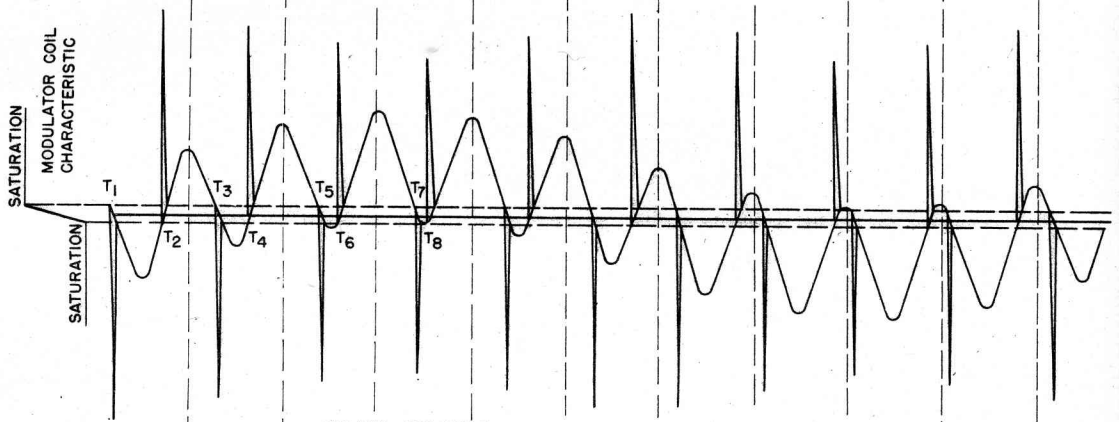

FIG. 36d - INDUCTIVE KICKS GENERATED IN THE MODULATOR COIL

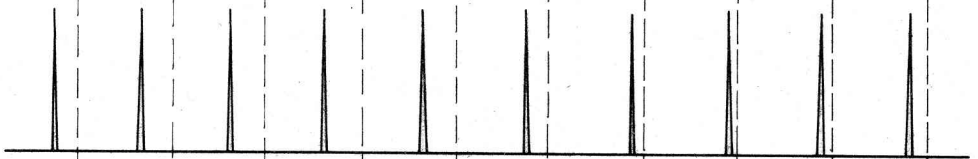

FIG. 36e - RECTIFIER OUTPUT

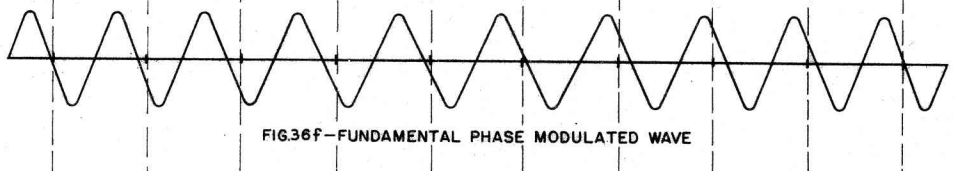

FIG. 36f - FUNDAMENTAL PHASE MODULATED WAVE

Fig. 36. Radio Transmitter BC-684-A: Method of Modulation

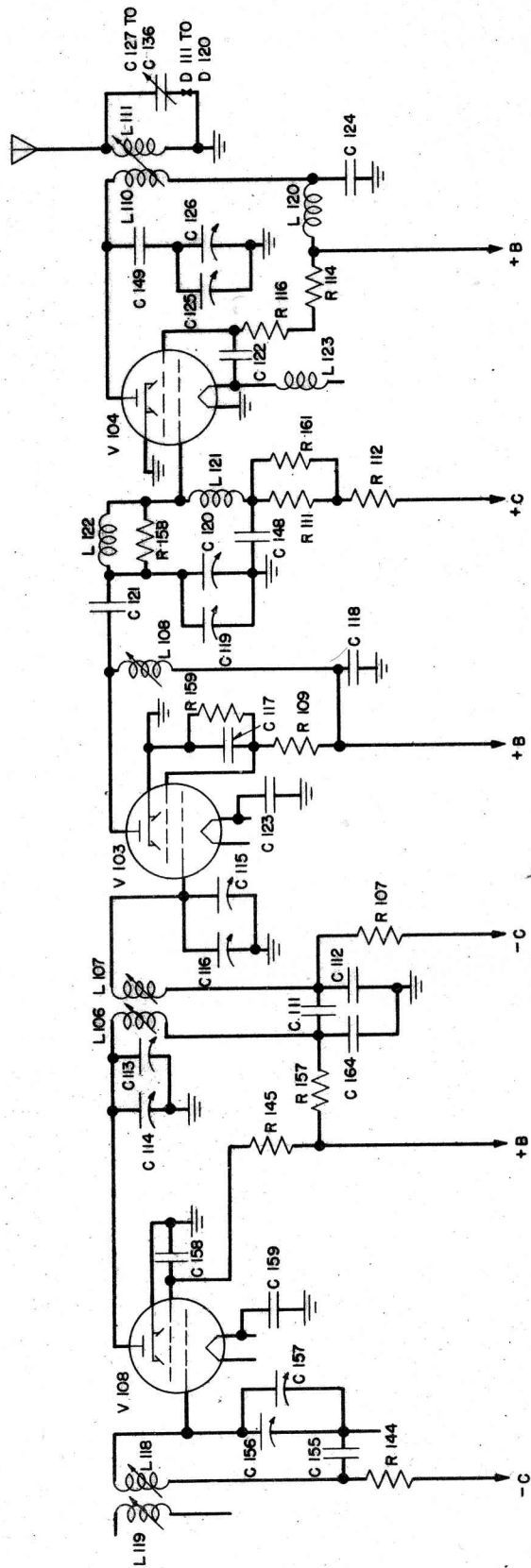

Fig. 37. Radio Transmitter BC-684-A: Functional Diagram of Tripler, Doubler, Power Amplifier, and Antenna Coupling Circuits

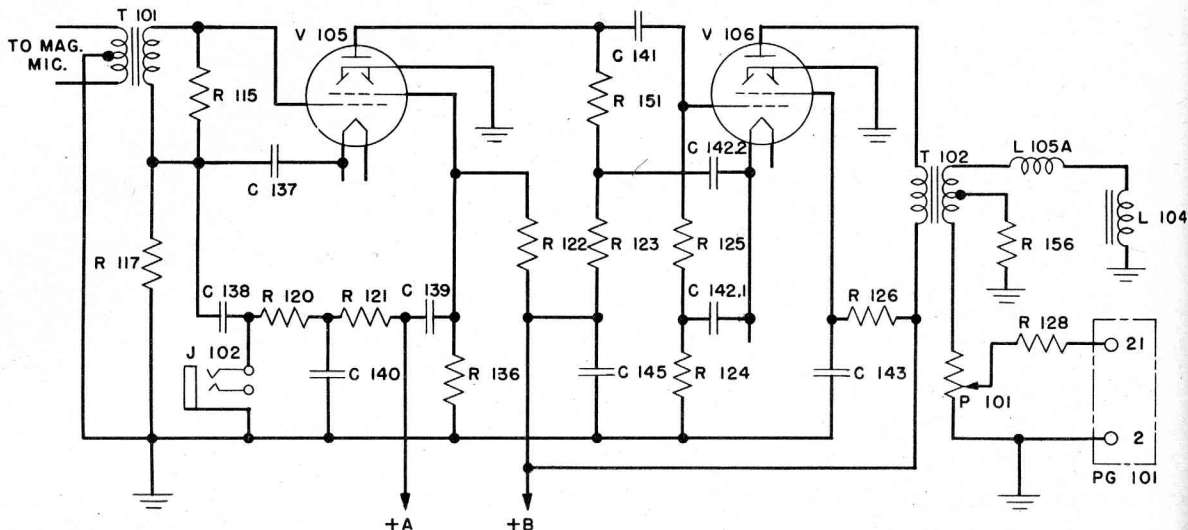

Fig. 38. Radio Transmitter BC-684-A: Functional Diagram of A-f Amplifier

quency) in the absence of any modulating signal. An audio-frequency (sine wave) signal is shown in Fig. 36b. As shown in Fig. 35, the two currents pass through L104 to ground. The combined current is shown in Fig. 36c. Figure 36d shows the inductive voltage peaks generated in L104 (near zero instantaneous coil current) by the combined current.

The peaked voltage across L104 is rectified by a biased rectifier, V102, as shown in Fig. 35. The fixed bias on the grid of V102 is sufficient to eliminate all portions of the wave shown in Fig. 36d except the upper peaks. The rectified output of V102 is illustrated in Fig. 36e. The wave shown in Fig. 36f is representative of the fundamental component of the wave in Fig. 36e. The difference between the evenly spaced intervals on the "time axis" and the points of "zero current" represents the amount by which modulation has shifted the wave.

The wave in Fig. 36e contains a large number of harmonic frequencies, each of which is similarly phase-modulated. A tuned filter (C152, C153, L119, L118, C156, and C157) suppresses all but the *twelfth* harmonic of the crystal frequency. This is passed on to the tripler stage of the transmitter.

e. Tripler, Doubler, Power Amplifier, and Antenna Coupling Circuits. A functional dia-

gram of the tripler (V108), doubler (V103), power amplifier (V104), and antenna coupling circuits is shown in Fig. 37.

The input to the tripler tube, the voltage across tuning capacitors C156 and C157, is at twelve times the crystal frequency, or one sixth of the output carrier frequency. Coupled anti-resonant circuits (C113, C114, L106 and C115, C116, L107) in the plate circuit of V108 and the grid circuit of V103 select the thirty-sixth harmonic of the crystal frequency and impress it upon the doubler stage, V103. The doubler output is tuned to the output carrier frequency by anti-resonant circuit L108, C119, C120. While capacitor C121 is included in the tuned circuit, it is of low reactance and is used only as a dc blocking capacitor. The power amplifier, V104, is coupled to the antenna by coupled circuits C125, C126, L110 and L111, C127-C136. L122-R158 is included in the grid lead of V104 to suppress high-frequency parasitic oscillations.

f. A-f Amplifier and Microphone Circuits. The essential circuits of the audio-frequency amplifier and the microphone circuits are shown in Fig. 38.

The first audio-frequency amplifier tube, V105, may be excited by a microphone. This may be a carbon-type microphone (either Microphone T-17 or T-30) connected to J102, or a magnetic

type microphone (Microphone T-33) connected to J101. In either case, pressing the switch on the microphone energizes the dynamotor relay winding (S102) and closes its contacts to start the transmitter dynamotor. The voltage from a magnetic-type microphone is impressed across the primary of input transformer T101. The secondary of T101 is loaded by resistor R115. The voltage across R115 is impressed upon the input of V105 through capacitor C137.

Since the output of a carbon-type microphone exceeds that of a magnetic-type microphone, means are provided to care for this difference. A magnetic-type microphone may be plugged into jack J101 or a carbon-type microphone may be plugged into jack J102. The desired uniformity of excitation of V105 (in spite of differences in microphone output) is obtained by the voltage divider action of capacitors C137 and C138. C138 is smaller than C137 and the audio signal voltage across C137, which is the excitation for V105, is proportionally smaller. The d-c microphone current is obtained through a ripple filter (R120, C140, and R121), from the vehicle battery.

The output of V105 is coupled to the grid of V106 by capacitor C141 and resistors R151 and R125. R123 is a noise filter resistor for the plate of V105. Capacitor C145 serves as a ground return for the plate circuits of V105 and V106.

Output transformer T102 has two series-connected secondary windings. One winding supplies sidetone to terminal 21 on plug PG101 through resistor R128. The sidetone volume is adjusted by varying the setting of potentiometer P101. The second winding supplies modulating signals to the modulation coil, L104, through radio-frequency choke coil L105A.

g. Metering Circuits. A single meter, M101 (Fig. 74), may be switched to any one of several circuits in the transmitter by operation of switch D125. The panel switch D121 is used to connect the meter to D125 or to the thermocouple TC101 for indicating antenna current. The following six circuits may be checked by use of D125.

<i>Switch Position</i>	<i>Circuit</i>
1	Doubler grid
2	First r-f amplifier grid
3	Rectifier grid
4	Tripler grid
5	Power amplifier grid
6	Total plate and screen

25. Functioning of Remote Control Unit RM-29-D. A combined schematic and wiring diagram for the remote control unit is given in Fig. 76. The association of this unit with Radio Set SCR-608-A is also shown in the detailed system schematic diagram, Fig. 69, and is explained in Paragraph 27. For more detailed information on the functioning of the various components in Remote Control Unit RM-29-D, refer to Technical Manual TM 11-308 which covers this unit.

26. Functioning of Dynamotors DM-34-(*), DM-35-(*), DM-36-(*), and DM-37-(*). Four types of dynamotor are used with Radio Sets SCR-608-A and SCR-628-A. They are:

- Dynamotor DM-34-(*): Receiver (12 volts)
- Dynamotor DM-35-(*): Transmitter (12 volts)
- Dynamotor DM-36-(*): Receiver (24 volts)
- Dynamotor DM-37-(*): Transmitter (24 volts)

Each dynamotor combines the functions of a low-voltage (12-volt or 24-volt) d-c motor with a high-voltage (200 volts for the receiver; 600 volts for the transmitter) d-c generator in a single machine. Only one frame, one armature, one field winding, and one pair of bearings are required. The armature is wound with two separate windings, each of which is connected to its own commutator. Schematic and wiring diagrams of the four dynamotors are shown in Fig. 39. Apparatus location diagrams are shown in Fig. 40. Exploded views of the dynamotors are shown in Figs. 41 and 42. The parts numbers are given in Paragraph 41, Maintenance of Dynamotor.

27. Functioning of Control Circuits.

a. Radio Set SCR-608-A. Figure 69 is a system schematic drawing of Radio Set SCR-608-A showing control circuit wiring in the receivers, transmitter, and mounting. It also shows Remote Control Unit RM-29-D and field Telephone

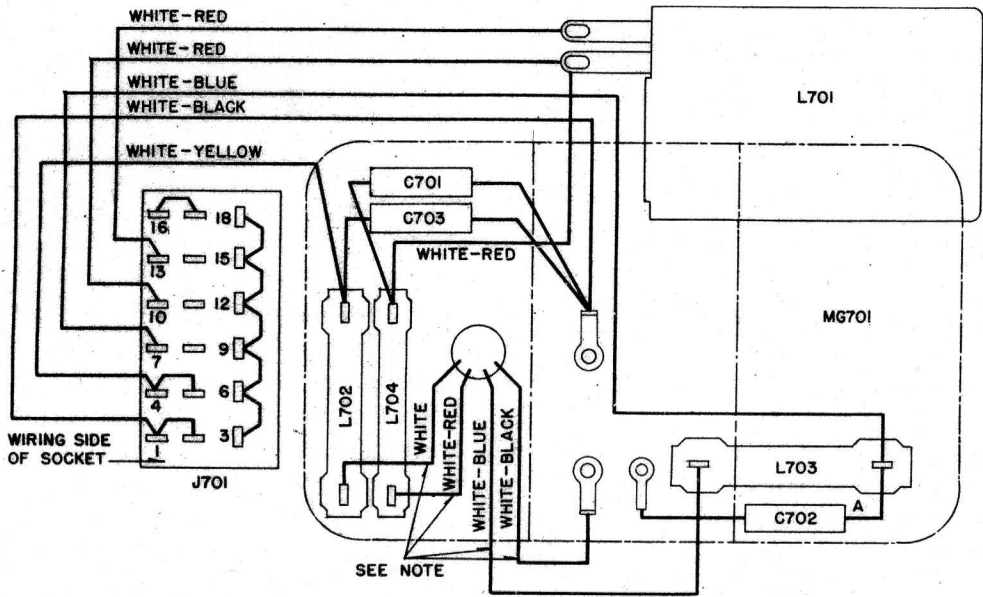

DYNAMOTOR DM-34-(*) , WIRING DIAGRAM

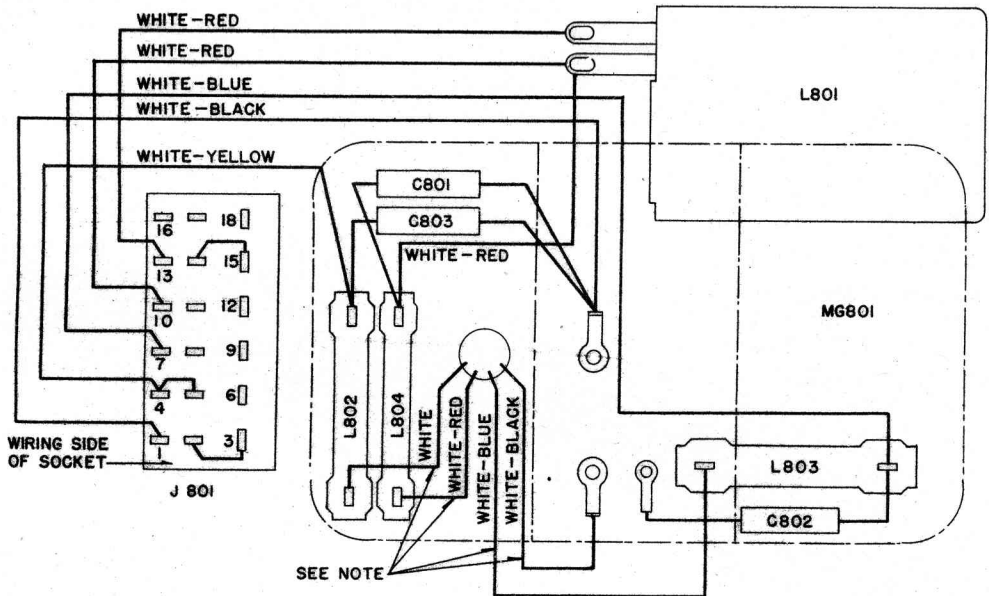

DYNAMOTOR DM-36-(*) , WIRING DIAGRAM

NOTE:
 THESE WIRES SHOULD BE KEPT AS FAR AS POSSIBLE
 FROM ALL OTHER WIRES.

Fig. 39. Dynamotors: Schematic and Wiring Diagrams

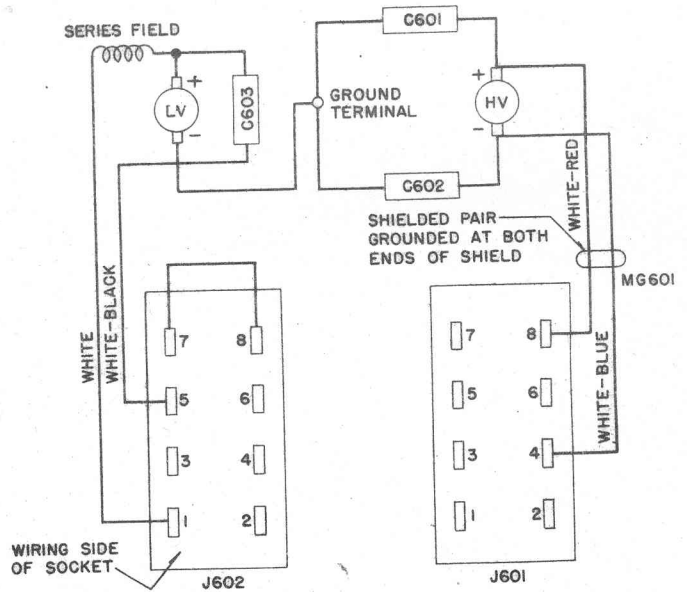
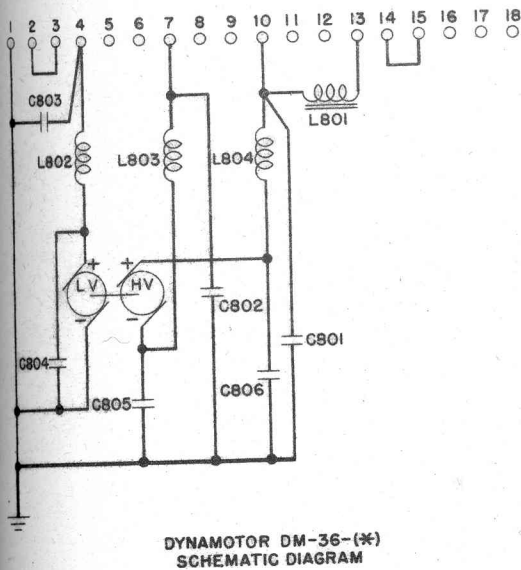
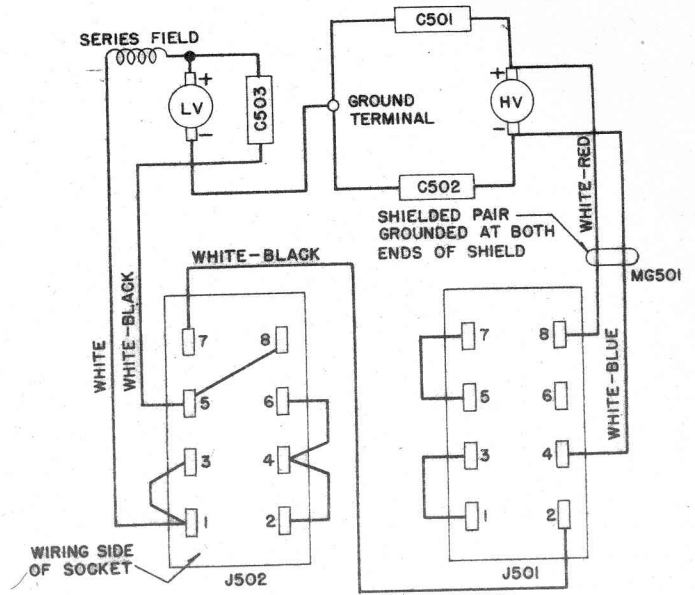
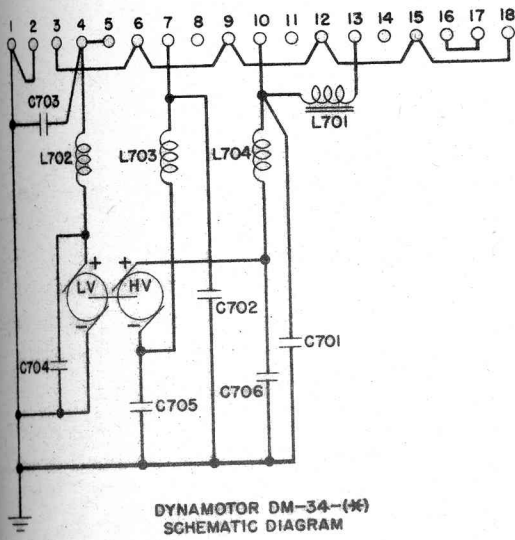

NOTE:
THE HIGH VOLTAGE LEADS FROM THE GROUNDED END
OF SHIELDING TO THE PLUG TERMINALS SHALL BE
COVERED WITH DIEFLEX FLEXIBLE VARNISHED
TUBING NO. 9 OR EQUIVALENT.

Fig. 39. Dynamotors: Schematic and Wiring Diagrams

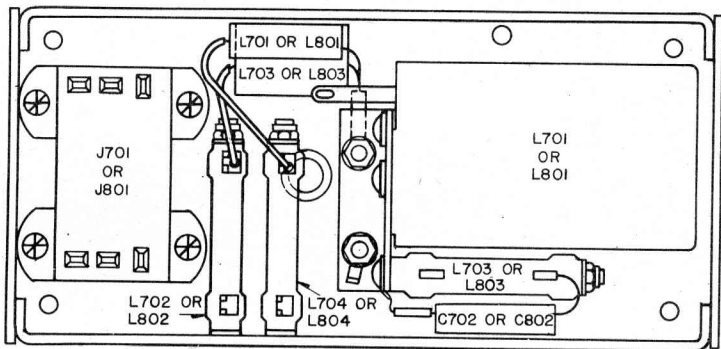
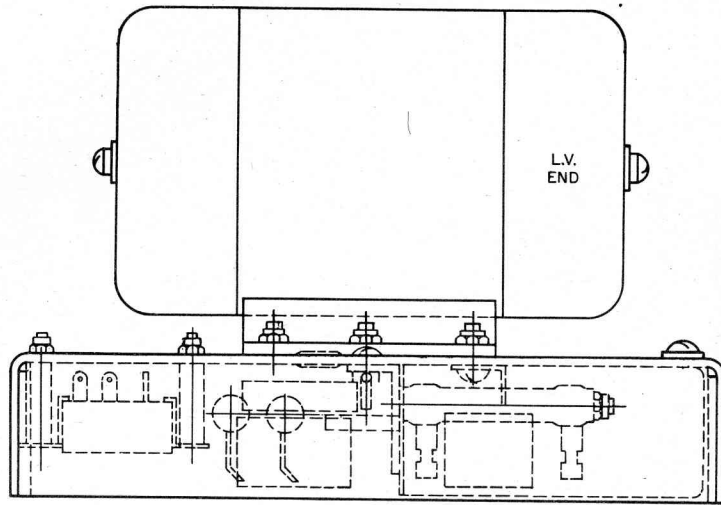

DYNAMOTOR DM-34-(*) AND DYNAMOTOR DM-36-(*)

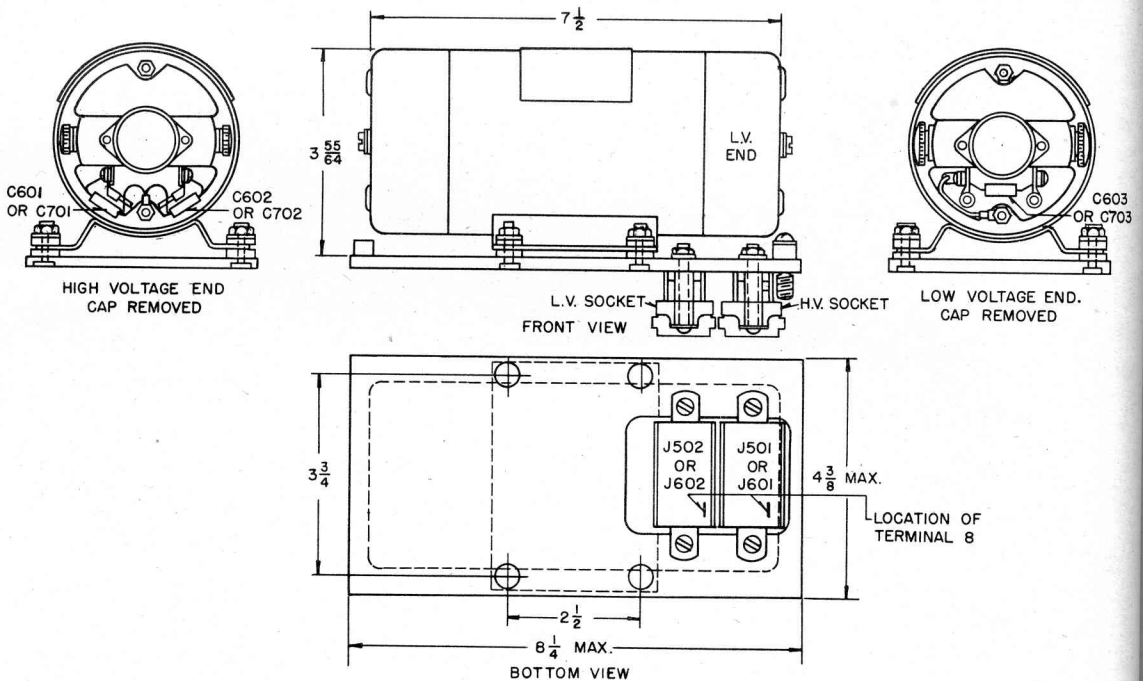

DYNAMOTOR DM-35-(*) AND DYNAMOTOR DM-37-(*)

Fig. 40. Dynamotors: Apparatus Location Diagrams

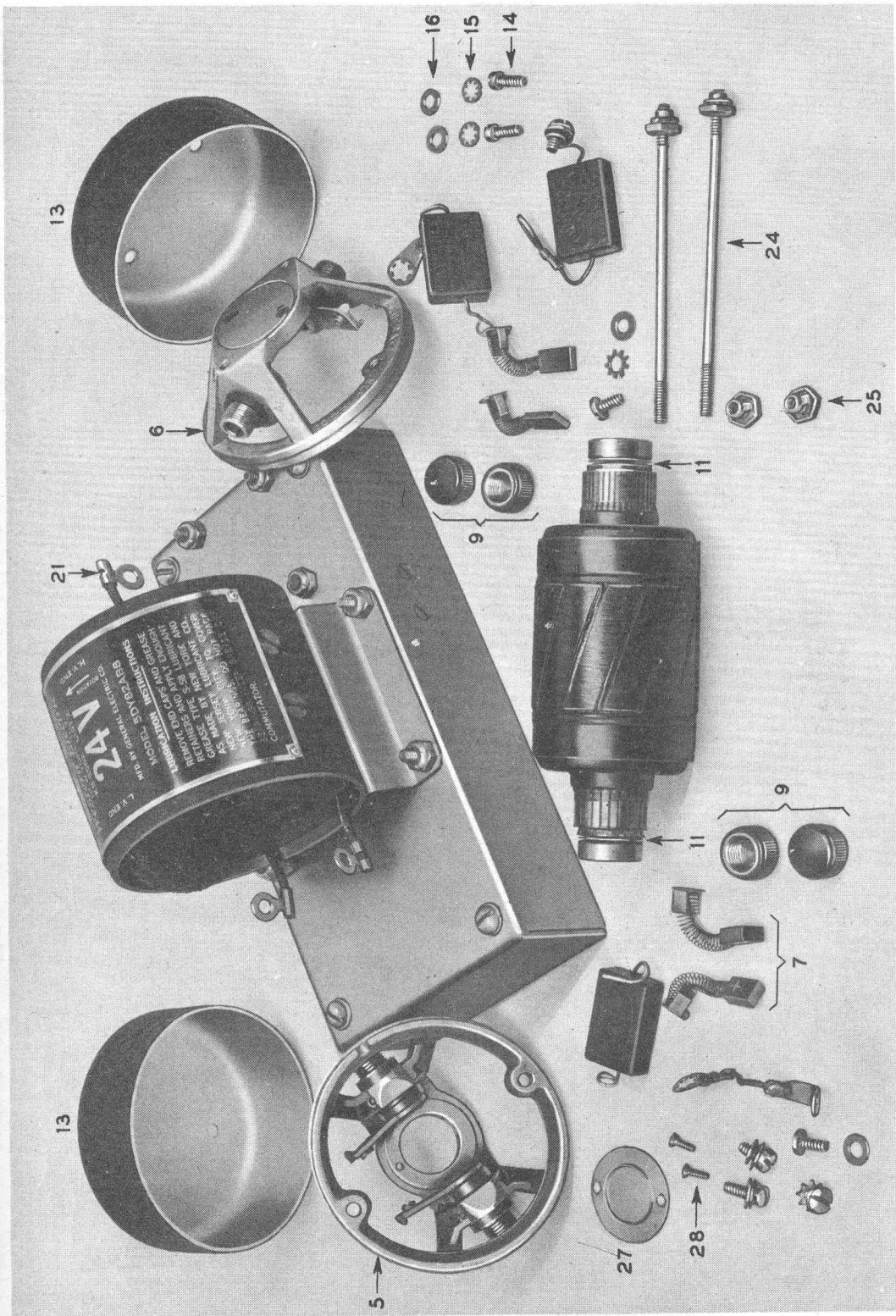

Fig. 41. Dynamotor DM-34-(*) or Dynamotor DM-36-(*): Exploded View

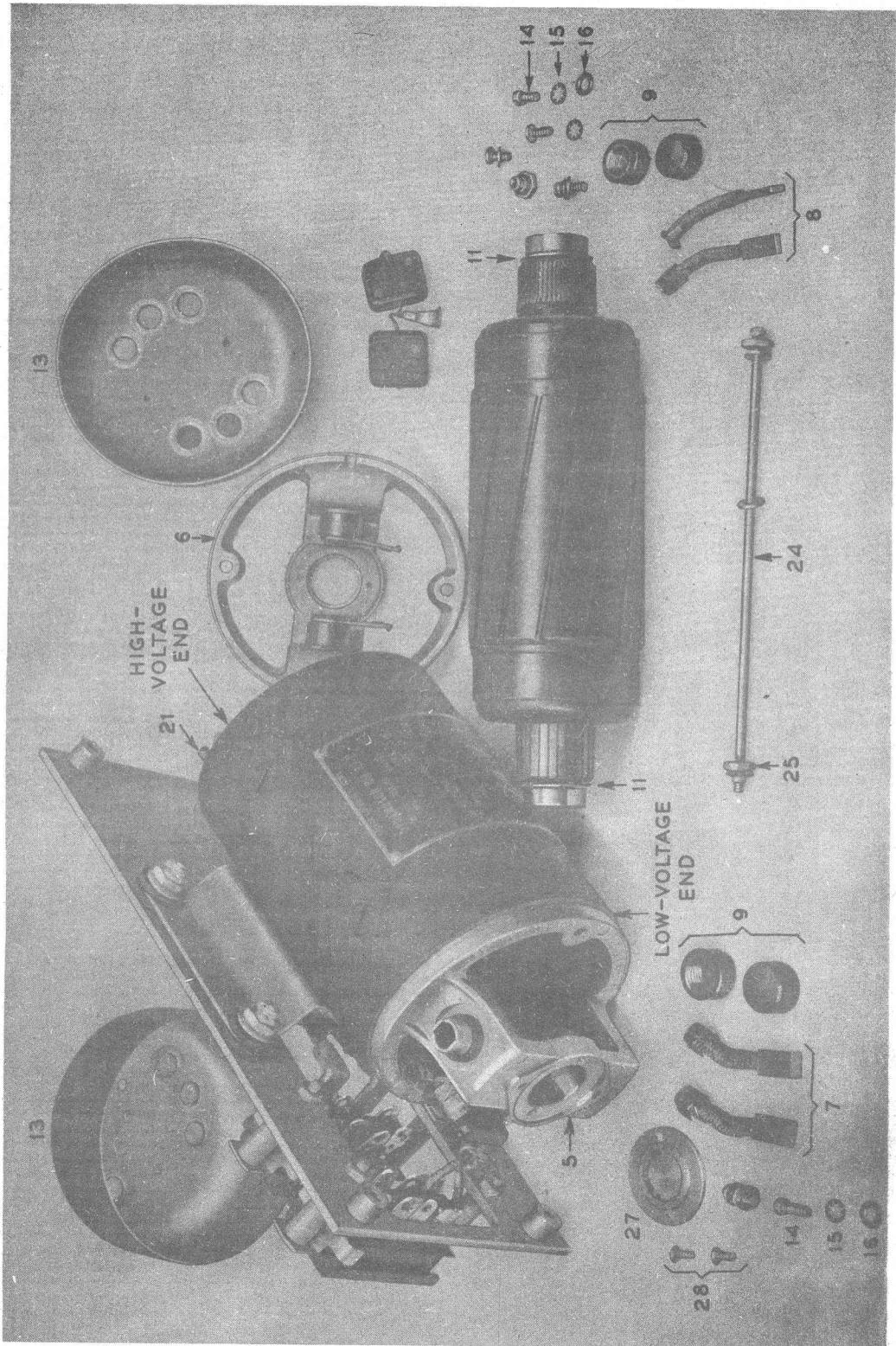

Fig. 42. Dynamotor DM-35-(*) or Dynamotor DM-37-(*): Exploded View

EE-8-(*), so that the wiring of a complete system is included. Refer to Fig. 69 for the discussion which follows.

Connections to the vehicle battery are shown at the lower right of the mounting. The negative side is grounded and the positive lead goes to terminal 1 of mounting receptacles J401, J402, and J403. On the corresponding plugs of the receivers (PG1), terminal 1 connects to the ON-OFF switches D1, and on plug PG101 of the transmitter, terminal 1 connects to the ON-OFF switch D124.

When a receiver ON-OFF switch D1 is closed, the receiver vacuum tube cathodes are heated and the receiver dynamotor starts. The output of either or both receivers is available at receiver headset jacks J1 and J2, when the OUTPUT TO PHONES switches D2 are at ON. Interconnection between headset jacks of the two receivers is over the lead connecting to terminal 21 of PG1. This lead also connects through the mounting to terminal 21 of the transmitter plug PG101, which goes to a winding on transformer T102 of the transmitter to provide sidetone in the receiver headsets when transmitting. Receiver output volume is adjusted by VOLUME control P1, and sidetone level is adjusted by potentiometer P101 in the transmitter. The receiver loudspeakers are turned on or off by switches D3. The antenna connection to the receivers is from the TR binding post on the mounting through terminal A1 of J403 and PG101, through a break contact of the transmitter antenna relay S101, through terminal A2 of PG101 and J403, through terminals A1 of J401 or J402 and PG1, to the grid of vacuum tube V1. Transmitter relay S101 is energized when transmitting, so that the receivers are disconnected from the antenna.

When the transmitter ON-OFF switch D124 is closed, the pilot lamp lights and the vacuum tube filaments are heated. When a carbon-type Microphone T-17 (or T-30) is plugged into jack J102 and the RECEIVER TUNE-OPERATE switch D122 is at OPERATE, the transmitter is ready for operation. Closing the microphone switch energizes dynamotor relay S102, thus starting the transmitter dynamotor. At the same time relays S101 and S103 in the transmitter are

energized. S101 is the antenna relay which transfers the antenna connection from the receiver to the transmitter, applies plate voltage to the power amplifier tube V104, and grounds the bias lead of the oscillator V107. S103 is the receiver disabling relay which, when operated, short-circuits the output of both receivers (leads from S103 contacts through terminals 7 and 22 of PG101 and J403, through terminal 7 of J402, J401, and PG1, to transformers T1 in receivers). Speech signals from the microphone through J102 are amplified in the audio amplifier tubes V105 and V106 and are impressed on the radio-frequency tubes via transformer T102. The lower secondary winding on T102 provides sidetone to the receiver headsets as previously described.

If a magnetic-type Microphone T-33 is used, it is plugged into jack J101 instead of J102. Closing the microphone switch grounds the dynamotor relay S102 winding over leads marked A and B and speech signals are impressed on the audio input transformer T101 via leads marked C and D. Otherwise, operation of the transmitter is the same as that described for the carbon-type microphone.

To furnish carrier-frequency voltage for setting push button selectors in the transmitter and the receiver without putting the transmitter "on the air," the RECEIVER TUNE-OPERATE switch D122 is provided in the transmitter. In the foregoing discussion of operation of the transmitter, it was stated that switch D122 was at OPERATE. When this switch is set to RECEIVER TUNE (after the ON-OFF switch is turned to ON), the transmitter dynamotor relay S102 is energized and the dynamotor starts without a microphone plugged in. The antenna relay S101 and receiver disabling relay S103 do not operate, however, so that carrier voltage is not applied to the antenna and the receiver output is not short-circuited.

Radio Set SCR-608-A may be used with Remote Control Unit RM-29-D and field Telephone EE-8-(*). These are also shown in Fig. 69, and a brief description of their function is given here.

Plug PL-55 of the remote control unit is plugged into a headset jack of the receiver and Plug PL-68 is plugged into the carbon-type microphone jack of the transmitter. A headset is

plugged into Jack JK-34-A of the remote control unit and a carbon-type microphone is plugged into Jack JK-33-A. Leads to the field telephone are connected at terminals L1 and L2. With Switch SW-185 of the remote control unit at RADIO, Jacks JK-33-A and JK-34-A are connected directly through to Plugs PL-68 and PL-55, respectively. When the transmitter and the receiver are turned on, operation is as previously described, except that speech signals pass through the remote control unit. The secondary of transformer C280 is not connected, so that no voice communication with field Telephone EE-8-(*) is possible. The field telephone station may ring the Ringer MC-131 in the remote control unit, however.

To communicate with a remote station, Switch SW-185 of the remote control unit is thrown to TELEPHONE, which disconnects Jacks JK-33-A and JK-34-A from Plugs PL-68 and PL-55 and connects them to transformer C280, also connecting Battery BA-27 in series to provide talking battery supply for the microphone at the remote

control unit. When a remote station is to be called, the handle on the crank of Generator GN-38 is lifted and rotated to the right.

To allow the remote station to transmit and receive over Radio Set SCR-608-A, Switch SW-185 in the remote control unit is set to THROUGH. In this position, the speech signals from the field telephone may be passed to the transmitter by pressing the ANTI-HOWL switch SW-175 in the remote control unit. The ANTI-HOWL switch must be released for speech signals from the receiver to be passed to the field telephone. It is not possible to transmit from the remote control unit when Switch SW-185 is at THROUGH, but the speech signals can and must be monitored with a headset in Jack JK-34-A.

b. Radio Set SCR-628-A. The functions of Radio Set SCR-628-A are exactly the same as Radio Set SCR-608-A except that only one receiver is furnished. With this difference the foregoing discussion of the functioning of Radio Set SCR-608-A applies to Radio Set SCR-628-A.

WAR DEPARTMENT TECHNICAL MANUAL

TM 11-620

RADIO SETS

SCR-608-A AND SCR-628-A

WAR DEPARTMENT • 1 JANUARY 1944

SECTION IV. MAINTENANCE

Special Notice to Maintenance Personnel: Before making replacement of any parts in this equipment, read Section V and particularly Paragraph 43 for changes in circuit components.

28. General Maintenance Information.

a. Precautions. Use care in servicing this equipment. Servicing should be done only by competent personnel who are supplied with adequate tools and test equipment. An inexperienced operator, in attempting to locate and repair a minor trouble which a competent serviceman could care for in a few moments, might misalign or damage the equipment to such an extent as to require its being sent to a repair depot.

When working with the transmitter, either in use or in testing, make sure that one of the push buttons is *always* depressed when the dynamotor is running. Also, turn the transmitter off whenever possible.

In the following instructions it is necessary in some cases to give values of voltage and current for certain conditions. Because of variations in tubes and other apparatus items, consider such values to be only approximations in most cases. As long as the result obtained does not differ greatly from the typical figure, it is probable that the unit in question is not in trouble.

Several drawings will be useful in connection with maintenance work on this equipment, particularly the location of trouble. The following are included in addition to those mentioned in previous paragraphs:

Fig. 51. Radio Receiver BC-683-A: Location of Alignment and Tuning Controls. This shows where the various knobs and screws are located for use in aligning the tuned circuits and in making other necessary adjustments.

Fig. 52. Radio Transmitter BC-684-A: Location of Alignment and Tuning Controls. This shows where the various adjustments are located for use in aligning

the tuned circuits and in making other necessary adjustments.

Fig. 57. Radio Receiver BC-683-A: Voltage Diagram. This shows the voltages to be expected under normal conditions from various points to the chassis.

Fig. 58. Radio Receiver BC-683-A: Resistance Diagram. This shows the resistance values to be expected from various points on the receiver to the chassis. All resistance measurements are made with the *dynamotor removed* from the receiver.

Fig. 59. Radio Transmitter BC-684-A: Voltage Diagram. This shows the voltages to be expected under normal conditions from various points to the chassis.

Fig. 60. Radio Transmitter BC-684-A: Resistance Diagram. This shows the resistance values to be expected from various points on the receiver to the chassis. All resistance measurements are made with the *dynamotor in place* in the transmitter.

Fig. 61. Mounting FT-237-(*): Schematic Diagram.

Fig. 62. Mounting FT-237-(*): Wiring Diagram.

b. General Information. The cleaning, inspecting, and testing procedures contained in this section are intended to prevent development of faults in field service. Operation failures are usually caused by dirt, loose connections, bad vacuum tubes, defective wiring or component parts, misalignment, or incorrect tuning.

Unless otherwise specified, make the following routine checks of the major components after every 300 hours of service. (Check the vehicle battery, charging generator, and voltage regulator prior to making tests of equipment installed in the vehicle.)

29. **Routine Check of Mounting.** Check the mounting and prepare it for testing of the radio set as follows:

- a. Be sure that the main fuse is intact and that the screws are tight.
- b. See that the spare fuse is in place.
- c. Inspect the transmitter and the receiver receptacles. Repair or replace any that are damaged.
- d. Inspect the insulators and the lead-in, and the connection at the left-hand end of the mounting.

30. **Routine Check of Radio Receiver BC-683-A.**

a. *Cleaning and Inspecting.*

- (1) Remove the receiver from the mounting.
- (2) Clean the outside of the cover and the front panel.
- (3) Remove the cover and see that the circuit label is secure.
- (4) Clean and inspect plug PG1. Make sure that there is a slight play in the plug mounting.
- (5) Carefully shake or blow out dust and dirt from the interior of the receiver. Avoid bringing a rag in contact with receiver parts as this may damage them.

Note: If an air hose is used be sure that any water condensed in it is blown out before applying the air stream to the equipment. Use only air intended for cleaning purposes and do not blow hard enough to misplace or damage any apparatus.

- (6) Inspect the set for:
 - (a) Loose or broken connections.
 - (b) Damaged parts.
 - (c) Evidence of excessive heating, such as burned resistors or melted wax. Such troubles can often be located by the sense of smell. Use your nose as well as your eyes.

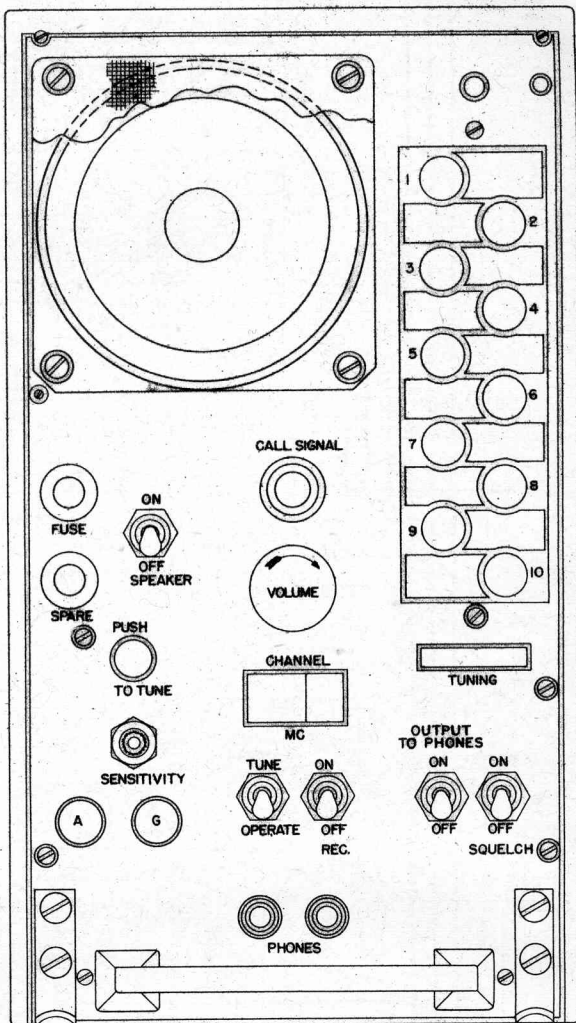

Fig. 44. Radio Receiver BC-683-A: Apparatus Location Diagram, Front View of Panel

- (7) Check both fuses and replace if necessary.
- (8) Dust off the push-button assembly with compressed air or a bellows.
- (9) Lubricate the push-button assembly as directed in Paragraph 30f.

Caution: Do not get oil on the locking wedge or friction washers.

- (10) Make sure all screws and nuts are tight. Check each socket mounting screw and each grounding screw with a screwdriver.

Caution: Do not use abnormal force when tightening screws. Take it easy.

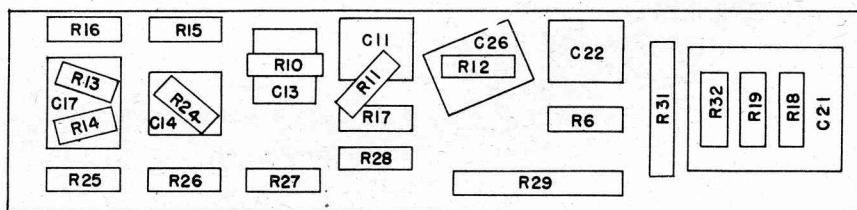
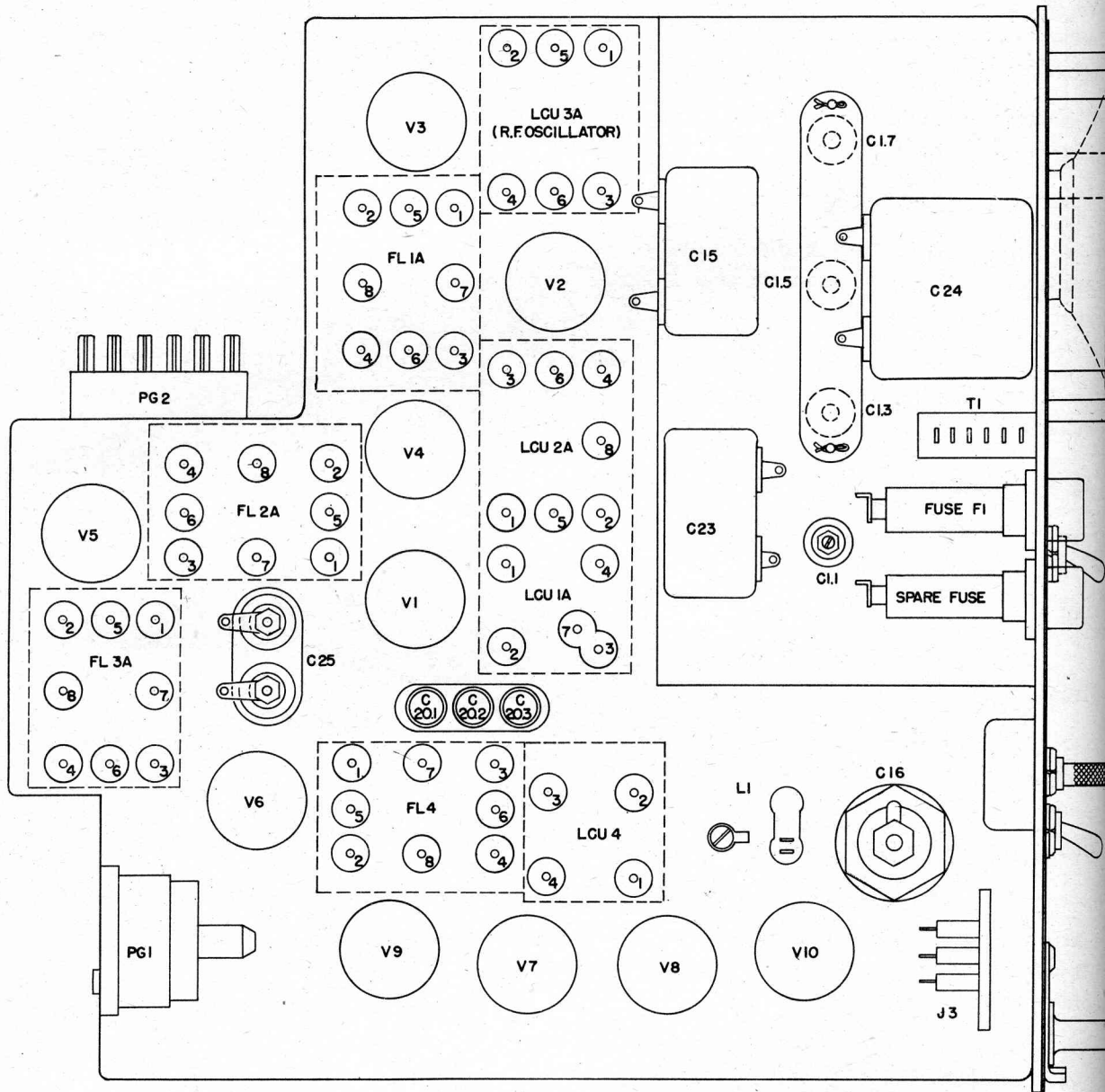

RESISTANCE STRIP

Fig. 45. Radio Receiver BC-683-A: Apparatus Location Diagram, Left-side View

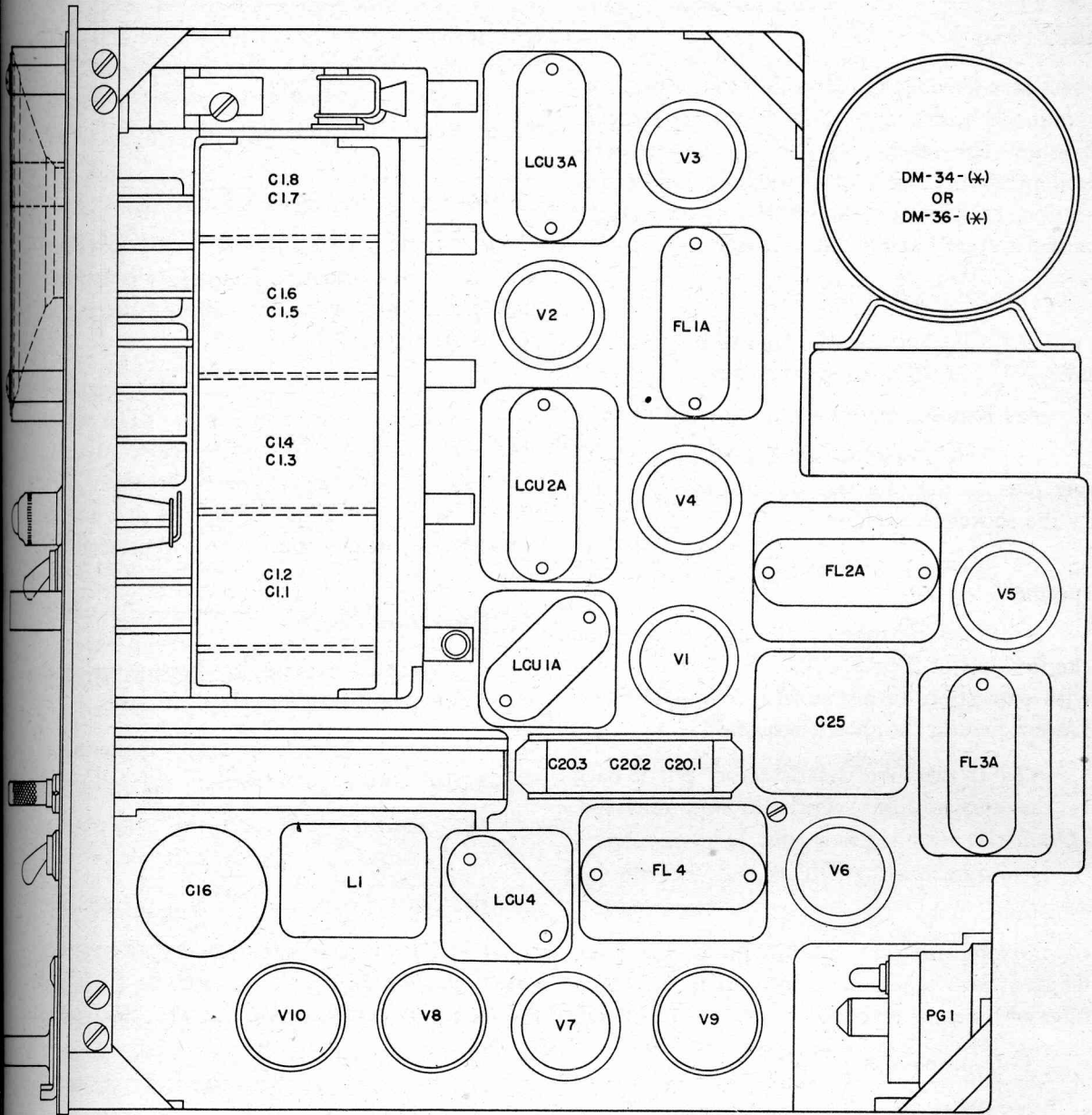

Fig. 46. Radio Receiver BC-683-A: Apparatus Location Diagram, Right-side View

(11) Inspect the sockets for dirty or damaged prong grips.

b. Dynamotor Routine. Remove the dynamotor end bells and dust off the commutator and brushes. The receiver dynamotor may be serviced in accordance with Paragraph 41 of this section. Make sure that the dynamotor voltage rating is correct for the vehicle battery.

c. Vacuum Tube Check.

(1) Check the radio-frequency amplifier tube, V1, for tightness in its socket.

(2) Remove the tube and clean the prongs.

(3) Repair or replace the socket if the contact pins on the tube are not gripped properly by the socket receptacles.

(4) Make sure that the tube is of the type specified, VT-112.

(5) Test the tube, if possible, in the tube checker unit of Test Set I-56-(*) in accordance with instructions furnished with the tube checker. Do not neglect the short-circuit test.

(6) If the tube is satisfactory put it back in the socket from which it was removed. (Otherwise install a new tube.)

(7) Repeat steps (1) through (6) for the remaining tubes.

Caution: Return each tube to the socket from which it was taken. It is important that even tubes of the same type shall not be interchanged.

d. Voltage Check.

(1) Place all switches on the receiver panel in the downward position. Remove cover.

(2) Connect the receiver to power, preferably with a test cord (such as Cord CD-786, one end of which plugs into a receptacle on the mounting and the other into the receiver under test). Otherwise insert the receiver into a mounting.

(3) Connect a 1000-ohms-per-volt voltmeter or a vacuum-tube voltmeter (250- or 300-volt scale) across capacitor C25, minus (—) to the blue lead and plus (+) to the red-white lead.

(4) Turn the REC switch to ON. Observe the wiring side of the chassis for smoke or sparks. If any are observed, turn the REC switch to OFF at once and check the set completely to remedy the trouble. Then proceed with the following tests:

Caution: High voltages are exposed.

(5) Make sure that, after the tubes are warmed up, the potential across C25 is approximately 200 volts when the supply battery is in good condition.

(6) Check the voltages at each terminal of V6 (limiter) as shown in Fig. 57. The values obtained should be reasonably close to those specified for V6. Approximate agreement with the values given in Fig. 57 indicates that normal voltages are being supplied to a representative tube.

e. Operation Check.

(1) Place all switches on the receiver panel in the downward position. Replace cover.

(2) Insert the receiver into a mounting in which a transmitter is mounted.

(3) Depress the first channel selector buttons on the transmitter and the receiver.

(4) Start the transmitter and the receiver.

(5) Throw the RECEIVER TUNE-OPERATE switch on the transmitter to RECEIVER TUNE and the TUNE-OPERATE switch on the receiver to TUNE.

(6) Throw the SPEAKER switch to ON. If the receiver is in the proper adjustment, and set for the same frequencies as the transmitter, the dial reading should agree with the channel in use; and a beat note should be heard in the loudspeaker.

(7) If no beat note is heard, check the transmitter and receiver controls to be sure that they are in the positions specified and set for the same frequency. If not, tune the receiver as described in Paragraph 21*b*. If the settings are correct and no beat note is heard, check the receiver in accordance with Paragraph 39.

(8) Throw the SQUELCH switch to ON and observe that the CALL SIGNAL lamp remains lighted. If necessary, adjust the SENSITIVITY control as described in Paragraph 20a(2).

(9) Repeat steps (5) through (7) for each channel set up on the receiver. Turn the RECEIVER TUNE-OPERATE switch on the transmitter back to OPERATE whenever the output is not needed.

(10) Check the operation of the manual tuning mechanism.

(11) Throw the RECEIVER TUNE-OPERATE switch to OPERATE.

(12) Throw the RECEIVER TUNE-OPERATE switch of the transmitter to RECEIVER TUNE. Operate the microphone push button and speak into the microphone. Check the loudspeaker output for normal volume and quality.

Note: The receiver output will be short-circuited by the disabling relay S103 in the transmitter if the RECEIVER TUNE-OPERATE switch is at OPERATE.

(13) Check the sidetone volume in the headset (OUTPUT TO PHONES switch in the OFF position) while talking into the microphone. If sidetone is not heard there may be trouble in either the receiver or the transmitter. Check them in accordance with Paragraph 39 or 40.

(14) Throw the RECEIVER TUNE-OPERATE switch on the transmitter to OPERATE, operate the microphone push button, and speak into the microphone. The sidetone volume should be satisfactory in the headset when the OUTPUT TO PHONES switch is set to ON.

(15) Release the microphone push button and check the volume of noise in the headset. Turn the SPEAKER switch to OFF and note that the noise volume in the headset remains the same.

f. Lubrication of Push-button Mechanism. Inspect the push-button mechanism occasionally. The push-button plungers should be lubricated with a very small amount of Univis 40 oil, or its equivalent. The rack and gears should be lubricated with Univis 115 oil, or its equivalent. Use

only a slight amount of oil, since too much oil may cause the plungers to stick under low-temperature conditions. If it is found necessary to clean the push-button mechanism, kerosene is the preferred cleaning fluid. Under field conditions, where the recommended lubricants may not be available, cleaning should be done with great care and lubricant omitted if the equipment is to be used under low-temperature conditions. *Do not get oil on the locking wedge or the friction washers.*

31. Routine Check of Radio Transmitter BC-684-A.

a. Cleaning and Inspecting.

(1) Remove the transmitter from the mounting.

(2) Clean the case and the panel.

(3) Clean and inspect plug PG101. Make certain that there is a slight play in the plug mounting.

(4) Turn the transmitter upside down and remove the bottom cover plate.

Important: After any repair, adjustment, or replacement of parts is made inside Radio Transmitter BC-684-A, always take a reading with an ohmmeter between coil L119 and ground. If the reading is zero resistance you will burn out resistor R119 as soon as you apply power. *Be careful.*

(5) Inspect the bottom of the transmitter for:

- (a) Loose nuts, bolts, or screws.
- (b) Loose or broken connections.
- (c) Damaged or worn parts.
- (d) Dirt.

(e) Excessive heating. Use your nose as well as your eyes.

(6) Carefully inspect relays S102 and S103. If either relay requires servicing, refer to Paragraph 31f.

(7) Inspect the spring and roller guides which keep the gang capacitor gear rack in place.

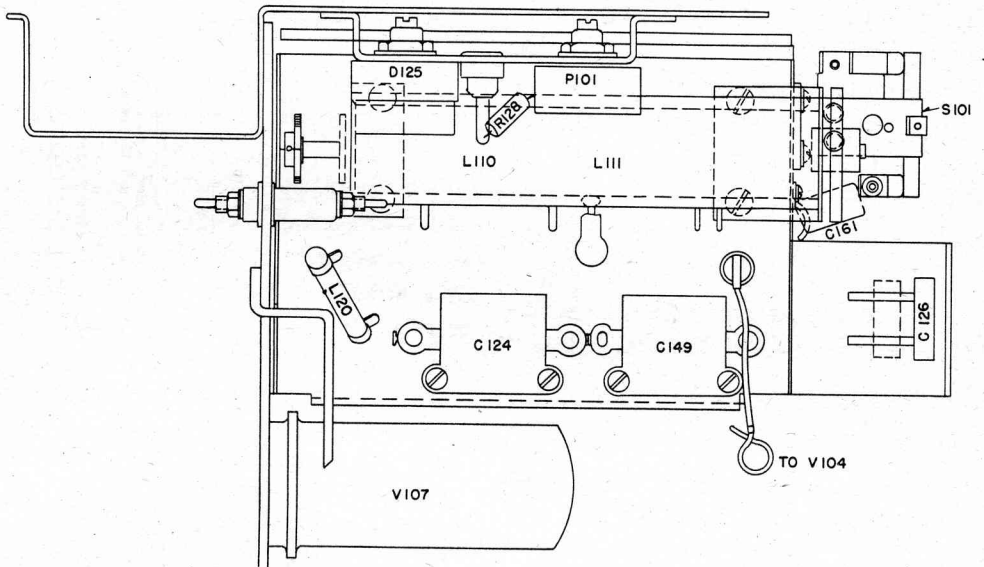

SECTION A-A (See Fig. 48)

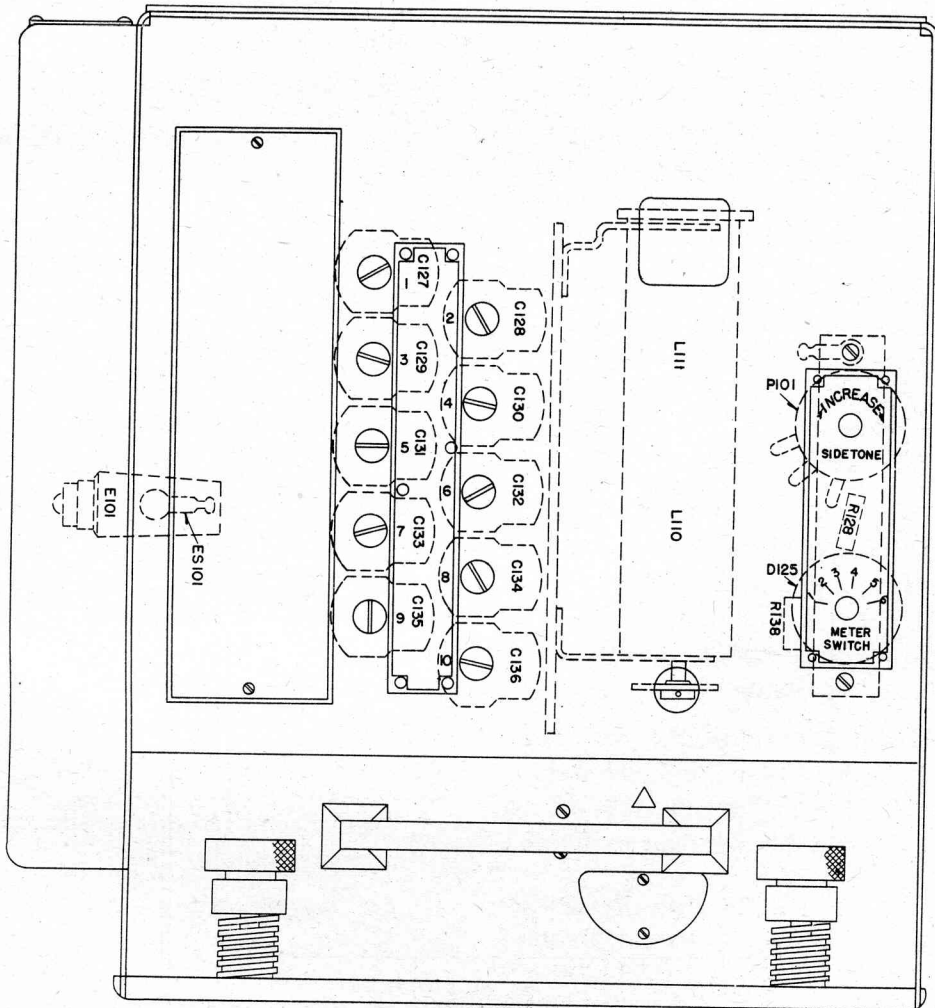

Fig. 47. Radio Transmitter BC-684-A: Apparatus Location Diagram, End View and Detail Through Section A-A

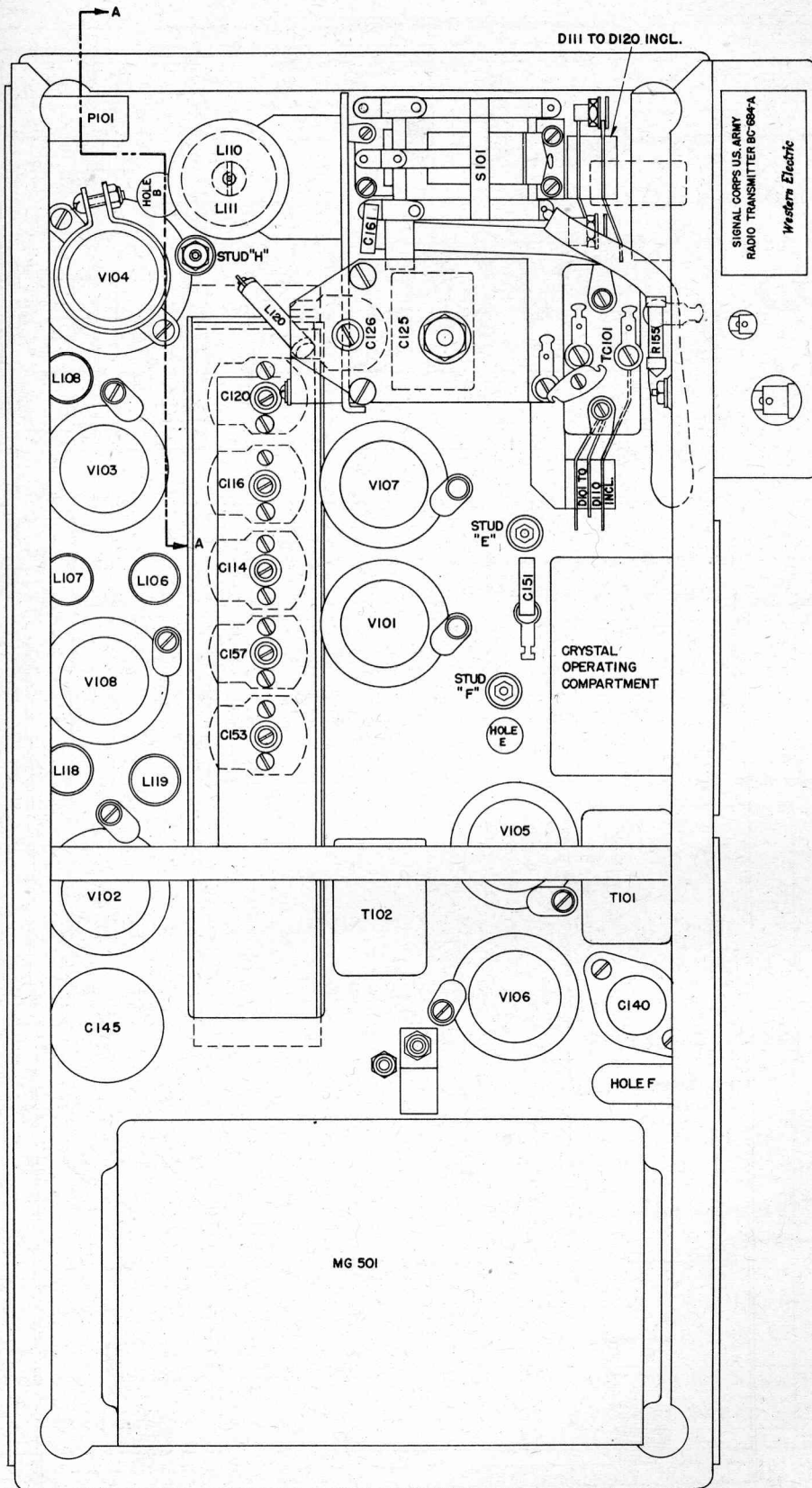

Fig. 48. Radio Transmitter BC-684-A: Apparatus Location Diagram, Top View

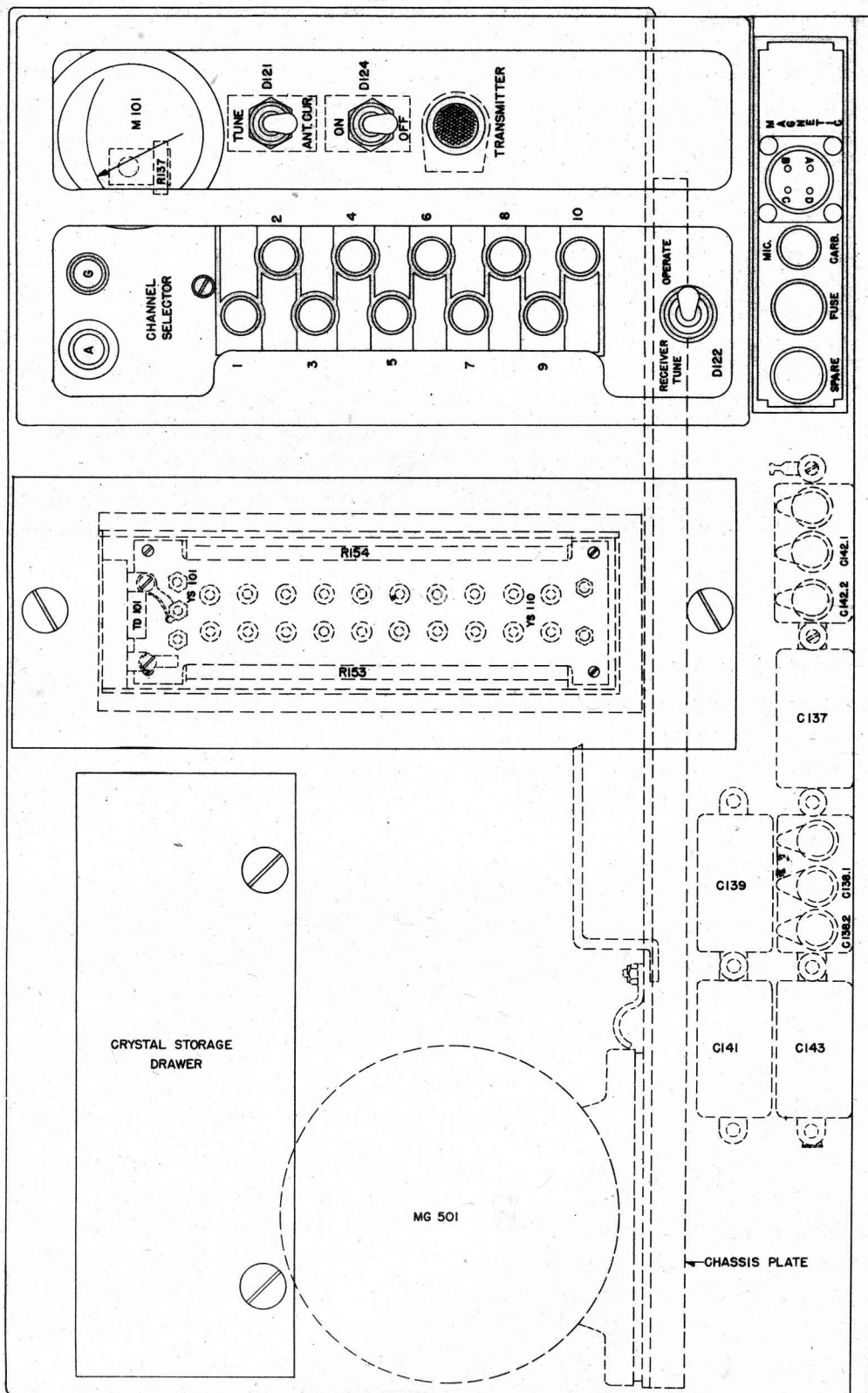

Fig. 49. Radio Transmitter BC-684-A: Apparatus Location Diagram, Front View

(8) Clean the bottom of the transmitter.

(9) Replace the bottom cover plate and turn the transmitter right side up.

(10) Remove the top cover plate and the crystal storage drawer. See that the circuit label is secure. (When the drawer has been pulled out to its most extended position it can be removed by raising the back portion and then rotating the front upwards to clear the catch under the back of the drawer.)

(11) Inspect the top of the transmitter for:

- (a) Loose nuts, bolts, or screws.
- (b) Loose or broken connections.
- (c) Damaged or worn parts.
- (d) Dirt.
- (e) Excessive heating.

(12) Carefully inspect relay S101. If this relay requires servicing, refer to Paragraph 31f.

(13) Clean the push-button assembly with compressed air or a bellows. Use of an air hose requires caution as noted in Paragraph 30a(5).

(14) Lubricate the push-button assembly as directed in Paragraph 31g.

Caution: Do not get oil on the locking wedge or friction washers.

(15) Check each socket mounting screw with a screwdriver.

Caution: Do not use abnormal force when tightening the screws.

(16) Check the security of the grounding points.

(17) Inspect the tube clamps.

b. Dynamotor Routine. The transmitter dynamotor may be serviced in accordance with Paragraph 41. Make sure that the dynamotor voltage rating is correct for the vehicle battery.

c. Vacuum Tube Check.

(1) Loosen the tube clamp and check the power amplifier tube, V104, for tightness in its socket.

(2) Remove the tube and clean its prongs.

(3) Repair or replace the socket if the contact pins on the tube are not gripped properly by the socket receptacles.

(4) Make sure that the tube is of the specified type, VT-165.

(5) Check the tube with a tube tester. Do not neglect the short-circuit test.

(6) If the tube is satisfactory, put it back in the socket from which it was taken and retighten the tube clamp. (Otherwise install a new tube.)

(7) Repeat steps (1) through (6) for the remaining tubes. The tubes in the remaining sockets are marked VT-164. Replace each tube in the socket from which it was removed.

d. Crystal Check.

(1) Open the crystal storage drawer and the crystal operating compartment and check the number of crystal holders issued.

(2) See that the required crystal holders are properly placed in the crystal operating compartment.

(3) Check each operating crystal for firmness in its socket.

(4) Replace the crystal storage drawer and the crystal operating compartment cover plate.

e. Operation Check.

(1) Remount the transmitter and associated receiver on the mounting in the vehicle.

(2) If radio transmission is not authorized, remove the antenna lead from the TR binding post on the mounting and connect Antenna A-83 (phantom) to the A and G terminals on the transmitter with short leads.

Note: If Antenna A-83 is not available, an antenna constructed according to Fig. 77 may be used. If, in an emergency, neither of these is available, a 40-watt, 115-volt Mazda lamp may be used. Notice, however, that neither the lamp nor the antenna according to Fig. 77 closely

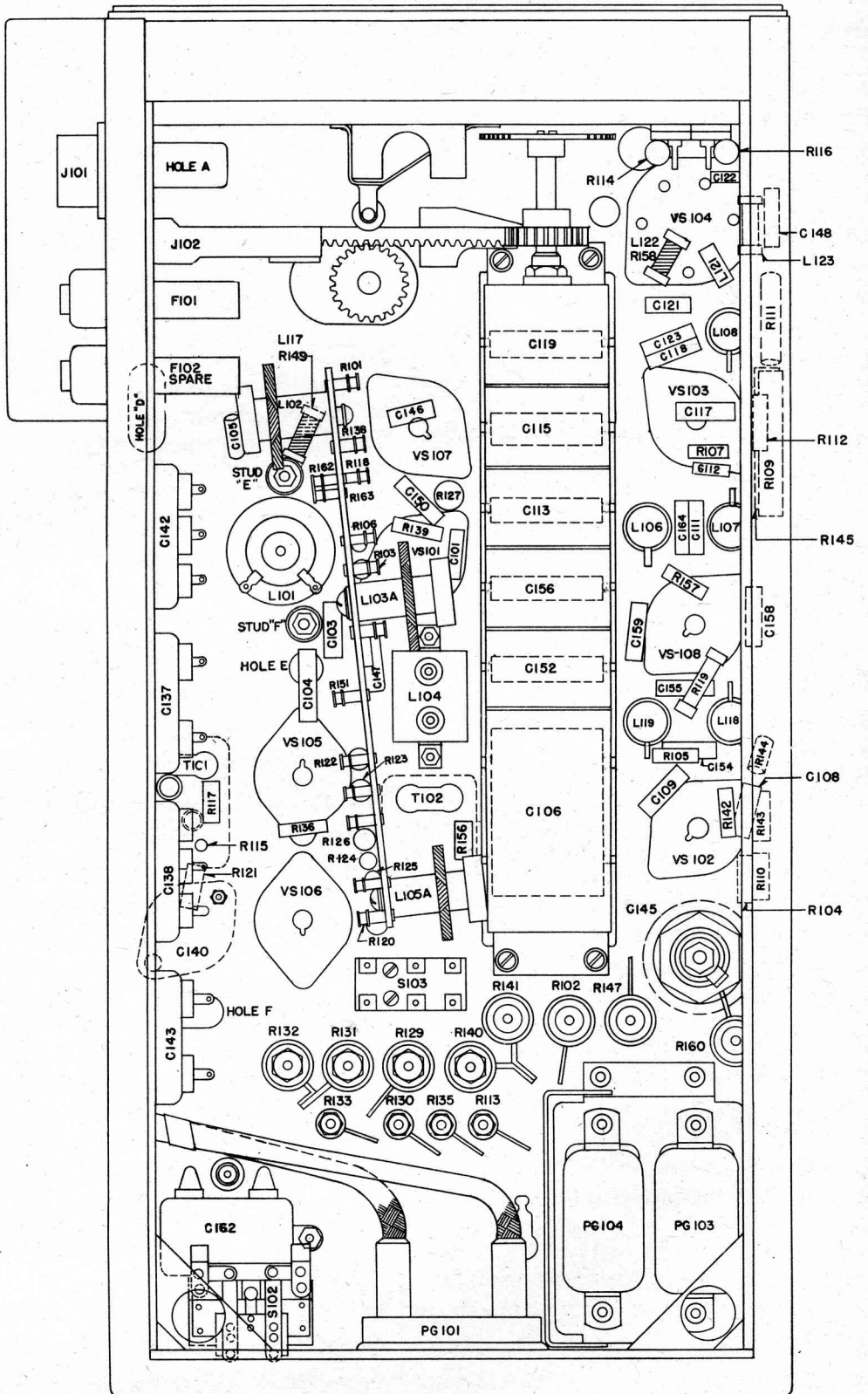

Fig. 50. Radio Transmitter BC-684-A: Apparatus Location Diagram, Bottom View

simulates the actual antenna; it is therefore doubly important to readjust the antenna trimmers, as covered in paragraph (11) following, after connecting to the real antenna.

(3) Plug in a microphone and a headset.

(4) Turn the transmitter and the receiver on and note that the transmitter pilot lamp lights.

(5) Throw the transmitter RECEIVER TUNE-OPERATE switch to OPERATE and the receiver OUTPUT TO PHONES switch to OFF.

(6) Press the microphone button, observe that the dynamotor starts, and talk into the microphone.

(7) Note that sidetone is heard in the headset and that its volume may be varied by adjusting the transmitter SIDETONE control.

(8) Tune the transmitter and the receiver to the same channel and throw the OUTPUT TO PHONES switch on the receiver to ON.

(9) Speak into the microphone and observe that the speaker's voice is heard in the headset.

(10) Turn the SPEAKER switch to ON and see that the speaker's voice is not heard. Throw the RECEIVER TUNE-OPERATE switch on the transmitter to RECEIVER TUNE and note the speech output is then obtained from the loudspeaker. Return to OPERATE at the transmitter.

(11) For each push button, check the meter readings in accordance with Paragraph 19b, Table V, for each of the METER SWITCH positions (TUNE-ANT CUR switch on TUNE) and for the ANT CUR position of the TUNE-ANT CUR switch. It may be necessary to adjust the antenna trimmers (C127 to C136) because of possible differences between the real antenna and the phantom antenna. There will be considerable variation in meter readings among different transmitters due to power supply, vacuum tube, and circuit variations. Experience with a number of transmitters is the best way to learn which readings are satisfactory and which are not. When the transmitter is set to RECEIVER TUNE the meter current for METER SWITCH position 5

will rise to about twice that shown in Table V and the current for METER SWITCH position 6 will drop to about half that shown in Table V. Paragraph 40e gives further information on these differences.

(12) If this check is made in cold weather, notice that the thermostat which controls the heaters in the crystal compartment operates at approximately 70 degrees Fahrenheit.

f. Relay Maintenance.

(1) *General.* Burnish the relay contacts with a burnishing tool or other thin flat piece of smooth metal. Never use abrasive papers or cloths. If the contacts become pitted, a fine file may be used to remove the rougher spots, after which the contacts should be burnished. Take precautions against metallic filings falling or being blown into the apparatus.

No provision is made for adjusting contacts and it should not be necessary under ordinary conditions. The contacts should be parallel when brought together. If some special situation makes it necessary to adjust the contacts, it is preferable to bend the contact arm rather than the spring (except for relay S101).

Warning: The spring assembly of S102 is connected to the vehicle battery even when the transmitter ON-OFF switch is in the OFF position and the green pilot light is extinguished. If you find it necessary to work on this relay be sure to disconnect the battery at plug PG101. If you don't, you are very likely to destroy the relay; you may also get a nasty burn on your hand.

(2) *Antenna Switching Relay S101.* The contact springs are mounted on Isolantite bars which are very brittle. Take care to avoid straining or deforming these bars. If any bending adjustment is required, it should be made on the springs. Keep the points clean.

(3) *Dynamotor Starting Relay S102.* Keep the points clean at all times. When the relay is released, the separation between points should be approximately the thickness of a thin dime. When the relay is operated, the armature travel

should be somewhat more than the amount necessary to close the points. Then the contact springs will be bent slightly and will exert some pressure to hold the points in good contact.

(4) *Receiver Disabling Relay S103.* The points should be kept clean.

g. Lubrication of the Push-button Mechanism. Inspect push-button mechanisms occasionally. Lubricate the push-button plungers with a very small amount of Univis 40 oil, or its equivalent, and the rack and gears with Univis 115 oil, or its equivalent. Use only a slight amount of oil. Too much oil may cause the plungers to stick under low-temperature conditions. (*Caution:* Do not get oil on the locking wedge or friction washers.) If necessary, clean the push-button mechanism with kerosene. Under field conditions, where the recommended lubricants may not be available, cleaning should be done with great care and lubricant omitted if the equipment is to be used under low-temperature conditions.

32. Routine Check of System.

a. Inspection of Antenna System.

(1) See that Wire W-128 or Coaxial Cord CO-282 between the antenna mast base and the binding post of the mounting is properly supported and that the connections are firm and not short-circuited.

(2) Be sure the proper antenna mast sections are installed and that their couplings are firmly joined.

(3) Inspect the antenna mast base carefully. Wipe off all dust and any vegetation that may have caught in the springs. Flex the base to be sure the springs are not broken and that the lead to the radio equipment is in good order.

(4) Carefully inspect all ground straps, if used, and all bolted connections in the ground system. Tighten or resolder any doubtful connections.

b. Talking Tests. Upon completion of the routine tests described in Paragraphs 28 to 32a,

inclusive, it is desirable, if practicable to do so, to talk between two vehicles. Make this test with Antenna A-83 (phantom) instead of the regular radiating system to prevent excessive signal radiation from either equipment. (If no Antenna A-83 is available, use an antenna constructed according to Fig. 77; if this is not possible, use a 40-watt, 115-volt Mazda lamp.) A two-way conversation test should be made with vehicles equipped with Radio Set SCR-608-A or Radio Set SCR-628-A.

33. Emergency Check of Receiver Output Volume and Circuit Alignment.

a. General. When the testing equipment for precision servicing of a receiver is not available, make a rough check of the alignment of the receiver circuits. The tests described may be made with the receiver mounted in the vehicle. Misaligned circuits so found may be realigned with a minimum of testing apparatus by following the directions in Paragraph 34. The location of the alignment controls is shown in Fig. 51.

b. Testing Apparatus Required.

- 1—Radio Transmitter BC-684-A known to be in good condition.
- 1—Microphone T-17 or Microphone T-33.
- 1—Output meter of Test Set I-56-(*) equipped with a 3½-foot assembly of Cordage CO-14 and Plug PL-55.
- 1—Volt-ohmmeter of Test Set I-56-(*), or a 1000-ohms-per-volt voltmeter, or a vacuum tube voltmeter, 3-volt scale.

c. Check of Output Volume.

- (1) Install the transmitter on the mounting.
- (2) Plug in a microphone and adjust the transmitter and the receiver to the same channel (the transmitter not operating).
- (3) Connect the plug and cord assembly of Test Set I-56-(*) to the \pm and VM terminals of the output meter, adjust the meter for the 15-volt scale, and insert the plug into one of the PHONES jacks on the receiver.

(4) Turn the SPEAKER switch to ON, throw the TUNE-OPERATE switch to OPERATE, the OUTPUT TO PHONES switch to ON, and the SQUELCH switch to OFF. Adjust the SENSITIVITY and VOLUME controls to the extreme right (maximum volume).

(5) Turn on the transmitter and the receiver and, after the vacuum tubes are hot, throw the RECEIVER TUNE-OPERATE switch on the transmitter to RECEIVER TUNE.

(6) Operate the microphone switch and whistle or shout for about three seconds into the microphone. The output meter should indicate 12 volts or more; if it does not, check the receiver in accordance with Paragraph 39. (Tune the receiver to the transmitter frequency.)

(7) Check the receiver VOLUME control by turning the control to the extreme left while whistling or shouting. The output meter reading should decrease uniformly to 1.0 volt or less; if it does not, it indicates that the VOLUME control may be defective or the amplifiers may be noisy.

d. Check of Circuit Alignment.

(1) Remove the receiver dust cover and place the receiver in the right-hand position of the mounting. Leave the left-hand position vacant.

(2) Turn the SPEAKER switch to ON, throw the TUNE-OPERATE switch to TUNE, and the SQUELCH switch to ON. Adjust the SENSITIVITY and VOLUME controls to the extreme right.

(3) Press any convenient channel push button on the transmitter. Operate both transmitter and receiver ON-OFF switches to ON. Operate the RECEIVER TUNE-OPERATE switch to RECEIVER TUNE.

(4) Manually tune the receiver to zero-beat with the transmitter frequency. Make sure that the CALL SIGNAL lamp lights. Read the setting of the receiver dial.

(5) Carefully adjust the tuning dial to each side of the zero-beat setting until the CALL SIG-

NAL lamp goes out. Note the two dial readings at which the lamp goes out. The lamp should remain lighted over approximately three channel divisions, and the zero-beat setting should be close to the center of this tuning range.

(6) Set the SENSITIVITY control to the extreme left (minimum sensitivity) and carefully adjust the tuning dial to each side of the zero-beat setting. The lamp should remain lighted over approximately two channel divisions; and the zero-beat setting should be at the center of this tuning range, within plus or minus one-half channel.

(7) If the zero-beat setting is found to be not centered, in steps (5) and (6), obtain the "reduced-voltage" points as described in Paragraph 33e following and realign the circuits as outlined in this paragraph.

e. Reduced-voltage Points.

(1) Connect the voltmeter across the limiter cathode choke (L1), with the minus (-) terminal of the meter connected to ground. (See Fig. 51.)

(2) Turn the SPEAKER switch to OFF, set the TUNE-OPERATE switch on OPERATE, and throw the SQUELCH switch to OFF.

(3) With the transmitter operating on RECEIVER TUNE, manually tune the receiver dial for a maximum deflection of the voltmeter. Note the voltmeter reading and the dial setting.

(4) Carefully adjust the tuning dial to each side of the maximum voltmeter deflection until the voltmeter indicates three fourths of the maximum deflection. Note the two dial readings so obtained. These are the "reduced-voltage" points. The dial should be found adjustable to between plus or minus one-half and plus or minus one channel division without reducing the voltmeter indication to less than three fourths of its maximum deflection.

(5) Throw the SPEAKER switch and the SQUELCH switch to ON, and the TUNE-OPERATE switch to TUNE.

(6) Tune for zero beat with the transmitter frequency. The zero-beat setting of the dial should be centered between the "reduced-voltage" points. If the zero-beat setting is not centered, the intermediate-frequency oscillator should be adjusted as described in Paragraph 34. If the zero-beat setting is centered with respect to the "reduced-voltage" points but not centered with respect to the dial settings at which the CALL SIGNAL lamp goes out, realign the discriminator circuit, FL4, as described in Paragraph 34.

34. Emergency Alignment of Radio Receiver BC-683-A.

a. General. When a receiver is found to be out of alignment it can be put into serviceable condition if another receiver or another transmitter in good condition is available. Whenever possible, check such emergency alignment in accordance with Paragraph 37. The method using a good receiver is described first as it permits alignment of all stages.

b. Method Using Good Receiver.

(1) *Testing Apparatus Required.* The following testing equipment is required:

- 1—Radio Receiver BC-683-A known to be in good condition.
- 1—Mounting FT-273-(*).
- 1—Insulated 1/4-inch hexagon socket wrench.
- 1—Resistor, 1000 ohms (not critical), equipped with clips. (To avoid accidental short circuits, the clips should be insulated, if possible.)
- 1—Voltmeter of Test Set I-56-(*), or other voltmeter of 1000 ohms or more per volt, equipped with approximately 3-foot leads (preferably twisted), and clips.
- 1—Twisted pair (one wire with tracer) about 3 feet long, with clips on both ends, one wire to have a capacitor of 0.001 microfarad or larger between the wire and the clip.
- 1—Wire about eight inches long, with clips at both ends.

3—Wires each about one inch long, with a clip at each end of each wire.

1—Cord CD-786.

Caution: When connecting or disconnecting these wires, turn the receiver off each time to avoid shocks or equipment damage.

(2) *Preliminary Steps.* The following steps in receiver alignment are divided functionally for convenience in description and understanding; but remember that in most cases a change in the alignment of any of the parts involves checking the adjustment of the other parts. The receiver under test will be referred to as the "trouble" receiver in the following discussion.

(a) Remove the covers from both receivers.

(b) Place all switches at OFF (or downward) in both sets. (The SQUELCH switch may have to be turned on subsequently as explained in paragraph (3)(a) following.)

(c) Secure the good receiver in the right-hand position of the mounting. Apply appropriate power to the trouble receiver by means of Cord CD-786 or equivalent.

(d) Turn both sets on and set the TUNE-OPERATE switches at TUNE.

(e) Allow both sets 10 to 15 minutes to warm up.

(f) Connect both chassis together using one wire of the above twisted pair. Use the wire which does *not* have the capacitor in series.

(3) *Tuning of the I-f Oscillator and the I-f Amplifier Tuned Circuits FL1A, FL2A, and FL3A.* A signal from the intermediate-frequency oscillator in the good receiver is picked up by connecting the 0.001-microfarad capacitor (which is attached to the twisted pair as just described) to terminal 7 of FL4 of the good receiver. The other end of the wire in series with the capacitor goes to the control grid (terminal 4) of the modulator (V2) in the trouble receiver, step (c). This tone passes through the intermediate-frequency amplifier and is used to beat with the intermediate-frequency oscillator in the trouble receiver. Thus this intermediate-

frequency oscillator can be tuned to zero-beat with that in the good receiver. As a quantitative indicator for tuning the intermediate-frequency circuits, a 3-volt (1000-or-more-ohms-per-volt) voltmeter is bridged across L1, step (e). A rough adjustment of FL1A, FL2A, FL3A, step (f), may be necessary in order to pass enough intermediate-frequency tone for beating with the intermediate-frequency oscillator. Unless the intermediate-frequency amplifier in the good receiver is shorted, step (b), noise will be superimposed on the test signal. In order to avoid undesirable interference in the alignment, the radio-frequency oscillator in the trouble receiver is disabled by increasing the bias on the grid, step (a). In order to avoid flattened response and consequent errors in alignment, the delayed-automatic-volume-control load resistor, R14, is shorted, step (a). It may be necessary to turn the SQUELCH switch to ON and adjust the SENSITIVITY control until an accurate tuning indication is obtained. In aligning the secondary of an FL unit a 1000-ohm resistor is connected across the primary to improve the accuracy of the adjustment. Similarly, in aligning the primary the resistor is connected across the secondary.

(a) Short-circuit R14 of the trouble receiver. Also connect terminal 5 of V3 to C25—the side to which blue-tracer wires are attached. (It may be necessary to turn the SQUELCH switch to ON and adjust the SENSITIVITY control to obtain a usable reading on the voltmeter when tuning the FL units.)

(b) Short terminals 1 and 2 of FL3A of the good receiver with a short clip lead.

(c) Connect terminal 7 of FL4 in the good receiver through the series capacitor to terminal 4 of V2 in the trouble receiver. Use for this the remaining wire of the twisted pair, the wire which has the capacitor in series. The untwisted part at the ends should be as short as possible. The capacitor should be nearest to the good receiver.

(d) Place the SPEAKER switch of the trouble receiver at ON.

(e) Clip the 3-volt meter across L1 of

the trouble receiver with the negative side on the ground lug.

(f) If the receiver is seriously misaligned, obtain a rough alignment by adjusting the slugs in FL3A, FL2A, and FL1A, in that order, for maximum meter reading. (The 1000-ohm shunt is not used in this procedure.)

Note: If no change in meter reading is observed when the slugs of FL3A are adjusted, turn the good receiver on and off and note the deflection of the meter. If this does not cause any change in deflection the trouble receiver may be faulty and require service. If the deflection is too small for satisfactory reading, the connection at terminal 7 of FL4 may be moved to terminal 2 of FL4 to obtain a larger reading for the preliminary adjustment. After that preliminary adjustment it should be returned to terminal 7 of FL4 which gives a signal strength more appropriate for the subsequent tests.

Caution: The lock washers on the tuning slugs of the tuned circuits may be damaged by turning the slugs in too far. When any adjustment of these units is made, make sure that the tuning slugs bind sufficiently to insure permanency of setting. If they feel loose during adjustment, tighten the lock washers by turning them to the right with a small screwdriver.

(g) Align LCU4 of the trouble receiver for zero-beat and turn the TUNE-OPERATE switch to OPERATE.

(h) Clip the 1000-ohm resistor across terminals 3 and 4 of FL3A. Adjust the primary slug (p) for maximum meter reading.

(i) Remove the 1000-ohm resistor and clip it across terminals 1 and 2 of FL3A and adjust the secondary slug (s) for maximum meter reading.

(j) Repeat step (h) for FL2A.

(k) Repeat step (i) for FL2A.

(l) Repeat step (j) for FL1A.

(m) Repeat step (k) for FL1A and remove the 1000-ohm resistor when the alignment is completed.

(n) It is advisable to check all adjustments, especially that of LCU4.

(4) *Tuning of FL4: The Discriminator Circuit.* The voltmeter is connected across the discriminator load resistors, step (a). The secondary is adjusted for zero d-c output in this meter, step (b). As the secondary slug is adjusted through the proper point, the d-c reading will change polarity. The automatic volume control is restored to operation and the delay bias removed, step (c), and the meter is connected across the resistor (R38) in the plate circuit of V1, step (e), thus giving an indication of automatic-volume-control action amplified through V1. The primary of FL4 can then be adjusted for a minimum reading in the meter. The 1000-ohm shunt is used across the output of FL1A, step (d), to control the gain.

(a) Remove the meter and bridge it across terminals 3 and 7 of FL4. Polarity of the meter cannot be specified as it will depend on the adjustment.

(b) Align the secondary of FL4 for zero reading on the meter. Note that as the slug is varied in either direction from the zero reading, the alignment meter should move *up* scale for one direction and *down* scale for the other.

(c) Remove the short from R14, and ground terminal 1 of FL4.

(d) Place the 1000-ohm shunt between terminals 3 and 4 of FL1A.

(e) Remove the meter and bridge it between terminals 2 and 3 of LCU2A, the positive lead going to terminal 3. It may be necessary to use the 30-volt scale.

(f) Align the primary of FL4 for minimum meter reading.

(g) Remove both the 1000-ohm shunt and the meter.

(h) Remove the short between C25 and terminal 5 of V3.

(i) Remove the lead from terminal 4 of V2 of the trouble receiver, and from terminal 7 of FL4 of the good receiver.

(j) Remove the short between terminal 1 of FL4 and ground.

(5) *Tuning of the R-f Oscillator, Assuming the Intermediate Frequency to be Exactly*

2.65 MC. This involves beating the radio-frequency oscillator of the trouble receiver with that of the good receiver to give zero-beat in the loudspeaker. The stray pickup in the trouble receiver from the good receiver is sufficient so that no direct connection of the radio frequency between the two receivers is required. The intermediate-frequency oscillator of the trouble receiver has been adjusted and is thus suitable for beating purposes. The meter is bridged across L1, step (a), as an indicator to show when the current through the intermediate-frequency amplifier is increasing even though the frequencies are not close enough together to give an audible beat. It is left in this position to show when LCU1A and LCU2A are properly adjusted. The short is placed across R14, step (b), to avoid a flattened response curve, as discussed in Paragraph 34b(3). The intermediate-frequency oscillator is turned on, step (c), to provide a beat-note. At the upper end of the scale the oscillator is set by adjusting the trimmer C1.7 to give zero-beat in the loudspeaker. Since the intermediate frequency is nominally 2.65 megacycles, there must be a corresponding difference between the two oscillators involved in order to produce a beat tone which will pass through the intermediate-frequency amplifier. For the high-frequency end of the scale, set the trouble receiver dial at 39 megacycles and set the good receiver dial at $(39 - 2.65 =) 36.35$ megacycles. Then the trimmer, C1.7, is set for zero-beat in the loudspeaker. For the low-frequency end of the scale set the good receiver dial at 27 megacycles and the trouble receiver at 29.65 megacycles. With this setting the slug in LCU3A is set for zero-beat. These two adjustments are then made alternately until the oscillator "tracks" satisfactorily at both ends of the band.

(a) Bridge the meter across L1 (negative terminal toward ground).

(b) Place a short across resistor R14.

(c) Place the TUNE-OPERATE switch of the trouble receiver at TUNE and throw the TUNE-OPERATE switch in the good receiver to OPERATE.

(d) Assuming the intermediate frequency to be 2.65 megacycles, set the good re-

ceiver at $(39 - 2.65 =)$ 36.35 megacycles and the trouble receiver at 39 megacycles.

(e) Adjust the radio-frequency oscillator trimmer capacitor C1.7 of the trouble receiver to give zero-beat in the loudspeaker.

(f) Still assuming the intermediate frequency to be 2.65 megacycles, set the good receiver at 27 megacycles and the trouble receiver at $(27 + 2.65 =)$ 29.65 megacycles, and, in the same way, adjust the slug in LCU3A for zero-beat.

(g) Repeat the preceding two steps until the radio-frequency oscillator tracks at both ends of the band.

(6) *Check of the Intermediate Frequency and Readjustment of the R-f Oscillator.* In the foregoing procedure it was assumed that both the intermediate-frequency amplifier stages and the intermediate-frequency oscillator were adjusted to exactly 2.65 megacycles. Actually, a variation in this frequency over a moderate range will not interfere with satisfactory operation as long as the adjustment of the radio-frequency oscillator is consistent with the intermediate frequency. For example, if the dial of the trouble receiver is set at 39 when the intermediate-frequency amplifier (and oscillator) circuits of the good receiver and the trouble receiver are tuned for 2.5 megacycles, then set the dial of the good receiver at $(39 - 2.5 =)$ 36.5 megacycles for aligning the radio-frequency oscillator in the trouble receiver. Otherwise, the dial calibration will not be correct. For this reason, it is desirable to make the following tests which supplement Paragraph 34b(5) rather than supersede it. The trouble receiver is set (in the middle of the range) at 33 megacycles and the good receiver is adjusted to a frequency which will give zero-beat with the intermediate-frequency oscillator in the trouble receiver. The reading on the dial of the good receiver should be very close to $(33 - 2.65 =)$ 30.35 megacycles. (This reading serves as a guide. The second beat, to be obtained near 35.65, is a better indication of the accuracy of adjustment.) A similar beat, though not so strong, can be obtained by tuning the good receiver the same distance above the trouble re-

ceiver. (If the beat note cannot be found readily, due to insufficient pickup, connect the bared end of a piece of insulated wire to the A post of the trouble receiver and extend it across the top of the good receiver to act as an antenna. Remove this wire when the observation is complete.) This dial setting should be between 35.6 and 35.7 megacycles. This allows for the 0.05-megacycle tolerance at $(33 + 2.65 =)$ 35.65 megacycles. If it falls within that range, the radio-frequency oscillator is properly tuned and no further work on it is necessary. If not, steps (d) through (g) should be followed. Assume, as an example, that the two dial settings giving zero-beat were 30.35 and 35.35 megacycles. Half the difference between these frequencies represents the true intermediate frequency which, in this example, comes out as 2.5 megacycles. This figure is then used instead of 2.65 in steps (d) to (g). Ordinarily, the necessary correction will be obtained by a slight change in the trimmer C1.7 at the high end of the scale. The procedure to be followed if a correction is necessary is described in steps (a) through (g).

(a) Set the dial of the trouble receiver to 33 megacycles.

(b) Adjust the dial of the good receiver to give zero-beat at approximately 30.35 megacycles and note the dial reading at which it occurs.

(c) Leaving the trouble receiver tuned to 33 megacycles, retune the good receiver to obtain the (somewhat weaker) beat note between 35 and 36 megacycles. Note the dial reading.

(d) By subtraction, obtain the difference between the two dial readings obtained in steps (b) and (c).

(e) Divide this difference by two.

(f) The value obtained in this way is the actual intermediate frequency.

(g) Repeat the alignment procedure, (5)(d) through (g), for the radio-frequency oscillator, using this value in place of 2.65 megacycles.

(h) Make certain that the radio-frequency oscillator tracks at both ends of the band.

(i) Remove the short from terminals 1 and 2 of FL3A in the good receiver.

(j) Replace the cover on the good receiver.

(7) *Adjusting LCU1A and LCU2A.* In tuning the radio-frequency circuits a shunt is placed across FL1A, step (a), to avoid limiting action. Also, R14 is shorted and the SQUELCH switch turned to ON for the reasons just discussed. If the trouble receiver is not in a mounting, the ground on the primary at LCU1A is floating. Therefore, terminal 2 of LCU1A must be shorted directly to ground, step (b). Also, short the antenna post (terminal 3 of LCU1A) to terminal 2 and ground, step (b), as its effect on the adjustment of the secondary would be noticeable if it were allowed to float. Without the ground, this floating condition would exist as there is no termination across the primary of LCU1A when we are relying on stray pickup for the test signal. For preliminary alignment, at the top of the frequency band, adjust the trimmers C1.1, C1.3, and C1.5 to give maximum reading in the meter; at the bottom of the band, adjust the slugs of LCU1A and LCU2A for maximum meter reading. For final alignment, the 1000-ohm shunt should be removed, the good receiver turned off, and the final alignment of LCU1A and LCU2A made on noise alone at both ends of the scale. This procedure is given as step (k).

(a) Place a 1000-ohm shunt between terminals 1 and 2 of FL1A. Connect the 3-volt meter across L1 of the receiver with the negative side on ground lug. Short R14.

(b) Short terminals 3 and 2 of LCU1A to ground, using the shortest wires.

(c) Set the dial of the trouble receiver to 39 megacycles.

(d) Tune the good receiver at approximately 36.35 megacycles on the dial to give a beat note on the loudspeaker.

(e) Align C1.1, C1.3, and C1.5 for maximum reading on the meter.

(f) Set the dial of the good receiver at 27 megacycles.

(g) Tune the trouble receiver at approximately 29.65 megacycles to give a beat note.

(h) Adjust the slugs in both the primary

and secondary of LCU2A and the slug in LCU1A for maximum reading of the meter.

(i) Repeat steps (c) through (h) until these units track at both ends of the band. (This completes the rough adjustment.)

(j) Turn the good receiver off. Turn the SQUELCH switch of the trouble receiver to OFF. Remove the 1000-ohm shunt from FL1A of the trouble receiver.

(k) Repeat the alignment steps for LCU1A and LCU2A using noise background alone for maximum meter reading at both ends of the dial (27 and 39 megacycles).

(l) Remove the short circuit from R14. Remove also the meter, and the short circuits from terminals 3 and 2 of LCU1A to ground.

(m) Replace all cover plates securely.

(n) Replace the dust cover.

(o) Reset the push buttons using a transmitter as described in Paragraph 21a.

(p) Place the set in its installation and trim C1.1.

c. Method Using Transmitter.

(1) *General.* One, or possibly two, misaligned circuits in a receiver can be roughly aligned with the remaining circuits of the receiver, in an emergency, by using an associated transmitter, or the transmitter in a nearby vehicle, as a source of testing frequency. Such an emergency alignment should be checked in accordance with Paragraph 37 as soon as practicable. Alignment of the radio-frequency oscillator unit (LCU3A) should not be attempted by this method. In the instructions which follow, it is assumed that the radio-frequency oscillator is functioning properly.

It is also assumed here that the source of radio-frequency testing frequency is the associated transmitter. Modifications to adapt the method to the use of a transmitter in a nearby vehicle are obvious. (For example, when the local transmitter is used, the RECEIVER TUNE-OPERATE switch is turned to RECEIVER TUNE, whereas it is turned to OPERATE when another vehicle is used.)

Note: During the following tests, operate the

transmitter dynamotor only when reading the meter or making an adjustment which requires power from the dynamotor.

(2) *Testing Apparatus Required.*

- 1—Radio Transmitter BC-684-A known to be in good condition.
- 1—Mounting FT-237-(*).
- 1—Volt-ohmmeter of Test Set I-56-(*), or a 1000-ohm-per-volt voltmeter, or a vacuum-tube voltmeter. Meter to have a 3-volt scale and also a 10- or 30-volt scale.
- 1—Insulated 1/4-inch hexagon socket wrench.
- 1—IRC BT-1/2, 5000-ohm resistor or its equivalent with clips and short leads.
- 1—500-micromicrofarad mica capacitor with small clips and very short leads.
- 2—Wires, each 11/2-inches long, with a small clip on each end of each wire.
- 1—Wire, 6-inches long, with small clip on each end.

(3) *Emergency Alignment of I-f Oscillator.*

Align a defective or replacement LCU4 tuning unit as follows:

- (a) Install transmitter and receiver on the mounting. Place the receiver in the right-hand position.
- (b) Find the "reduced-voltage" points as directed by Paragraph 33e, and make your setting halfway between.
- (c) Remove the cover plate which permits access to the adjusting screw in LCU4.
- (d) Vary the setting of this screw until a beat note is heard. Carefully adjust for zero-beat. This step brings the replacement tuning unit, LCU4, into alignment with the intermediate-frequency amplifier.

(4) *Emergency Alignment of I-f Amplifier.*

Emergency alignment of an intermediate-frequency filter unit (FL1A, FL2A, FL3A) may be accomplished as follows:

- (a) Install the transmitter and the receiver in the mounting, with the receiver in the right-hand position.

(b) Connect the voltmeter (3-volt scale) across the limiter cathode choke, L1, as shown in Fig. 51.

(c) Disable the automatic-volume-control circuit by short-circuiting resistor R14. Use the short jumper wire with a clip on each end.

(d) Using the 6-inch jumper, wind a coil of four turns of 1/4-inch diameter about 1/2-inch long. Connect this coil between terminal 4 (control grid) of modulator tube V2 and the adjacent socket ground terminal. This shunt is to reduce the input to the intermediate-frequency amplifier to a point where the action of the limiter circuits will not mask the tuning point during tests. It may be found necessary to adjust the number of turns or the spacing to secure suitable values, step (h).

(e) Turn the receiver ON-OFF switch to ON; the TUNE-OPERATE switch to TUNE; the SPEAKER switch to ON; the SQUELCH switch to OFF; the VOLUME control to the extreme right. Release the tuning dial by depressing one of the CHANNEL SELECTOR push buttons part way.

(f) Adjust the transmitter to a channel near the 27-megacycle end of its frequency range. Turn the transmitter on. Place the RECEIVER TUNE-OPERATE switch on RECEIVER TUNE.

(g) After the receiver has had time to warm up, carefully adjust the receiver dial (use the same setting as on the transmitter) for zero-beat with the transmitter signal and note the maximum deflection of the voltmeter as the dial is tuned through the zero-beat point. The meter deflection should decrease as the dial is varied to either side of zero-beat. Restore the zero-beat adjustment after completing the observation.

(h) Remove the coil from V2 and note the reading of the voltmeter. The voltmeter reading with the coil in place should not be more than three fourths of the reading with the coil removed. If it is more, adjust the spacing of the turns or change the number of turns until a satisfactory reading is obtained.

(i) Replace the coil.

(j) Detune the receiver by several channels (to a point where no signals are being received) and note the minimum voltmeter read-

ing. (The voltmeter is effective as a tuning indicator only if its deflection is kept between the minimum value and the "three-fourths" reading, step (h). Therefore, keep the deflection within this range at all times during this procedure.)

(k) Remove the cover plates from the tuning unit (FL1A, FL2A, or FL3A) to be aligned.

(l) Adjust the p (primary) and s (secondary) adjusting screws of the tuning unit for a rough approximation of the maximum voltmeter deflection.

(m) Connect the 5000-ohm resistor between terminals 3 and 4 of the tuning unit being adjusted.

(n) Adjust the p screw for a maximum voltmeter reading. See the Note following step (p).

(o) Remove the resistor from terminals 3 and 4 and connect it between terminals 1 and 2.

(p) Adjust the s screw for maximum voltmeter reading.

Note: Check the zero-beat setting occasionally as the work progresses. Also, keep the voltmeter within the limits given in step (j) by adjusting the shunting coil as necessary. Remove the coil and the 5000-ohm resistor.

(5) *Emergency Alignment of R-f Amplifier.* Make an emergency alignment of a radio-frequency tuning unit (LCU1A or LCU2A) as follows:

(a) Install the transmitter and the receiver in the mounting, with the receiver in the right-hand position.

(b) Connect the voltmeter (3-volt scale) across the limiter cathode choke, L1, as shown in Fig. 51.

(c) Disable the automatic-volume-control circuit by short-circuiting resistor R14. Use the short jumper wire with a clip on each end.

(d) Connect the 500-micromicrofarad capacitor between terminals 1 and 2 of filter unit FL1A. (The capacitor reduces the signal input to the intermediate-frequency amplifier sufficiently to prevent limiter action from masking the desired tuning point in the test.)

(e) Remove the cover plates from the LCU1A and LCU2A tuning units and from the trimmer capacitors, C1.3, C1.5, and C1.7. (The cover plate of C1.7 is beside C24.)

Caution: Do not disturb the setting of the oscillator trimmer capacitor C1.7 during this alignment.

(f) Turn the SPEAKER switch to ON, set the TUNE-OPERATE switch to TUNE, and turn the SQUELCH switch to OFF. Turn the VOLUME control to the extreme right.

(g) Adjust the transmitter for operation near the 39-megacycle end of its frequency range and start the transmitter and the receiver. Place the transmitter in the RECEIVER TUNE condition.

(h) After the receiver has warmed up, carefully adjust the receiver dial for zero-beat with the transmitter (the receiver dial should read the frequency to which the transmitter is set). Adjust each of trimmer capacitors C1.1, C1.3, and C1.5, for maximum voltmeter deflection. If the 500-micromicrofarad capacitor bridged across terminals 1 and 2 of FL1A has not reduced the signal strength (from the transmitter) sufficiently to obtain a good range of meter deflection, a further reduction may be obtained by connecting that capacitor across terminals 1 and 2 of either FL2A or FL3A instead of FL1A. When the trimmers are properly set, the voltmeter deflection decreases as the set is detuned from the zero-beat point.

(i) Remove the 500-micromicrofarad capacitor shunt from terminals 1 and 2 of the filter unit shunted as called for in step (g). The voltmeter reading with the capacitor in place should be not more than three fourths of the reading with the capacitor removed. If it is more, the capacitor leads are too long, or the clips are not making good contact.

(j) Replace the capacitor and trim the settings of C1.1, C1.3, and C1.5, if necessary.

(k) Operate the transmitter near the 27-megacycle end of its frequency range and carefully adjust the receiver to zero-beat with the transmitter. The reading of the receiver dial should correspond with the transmitter frequency.

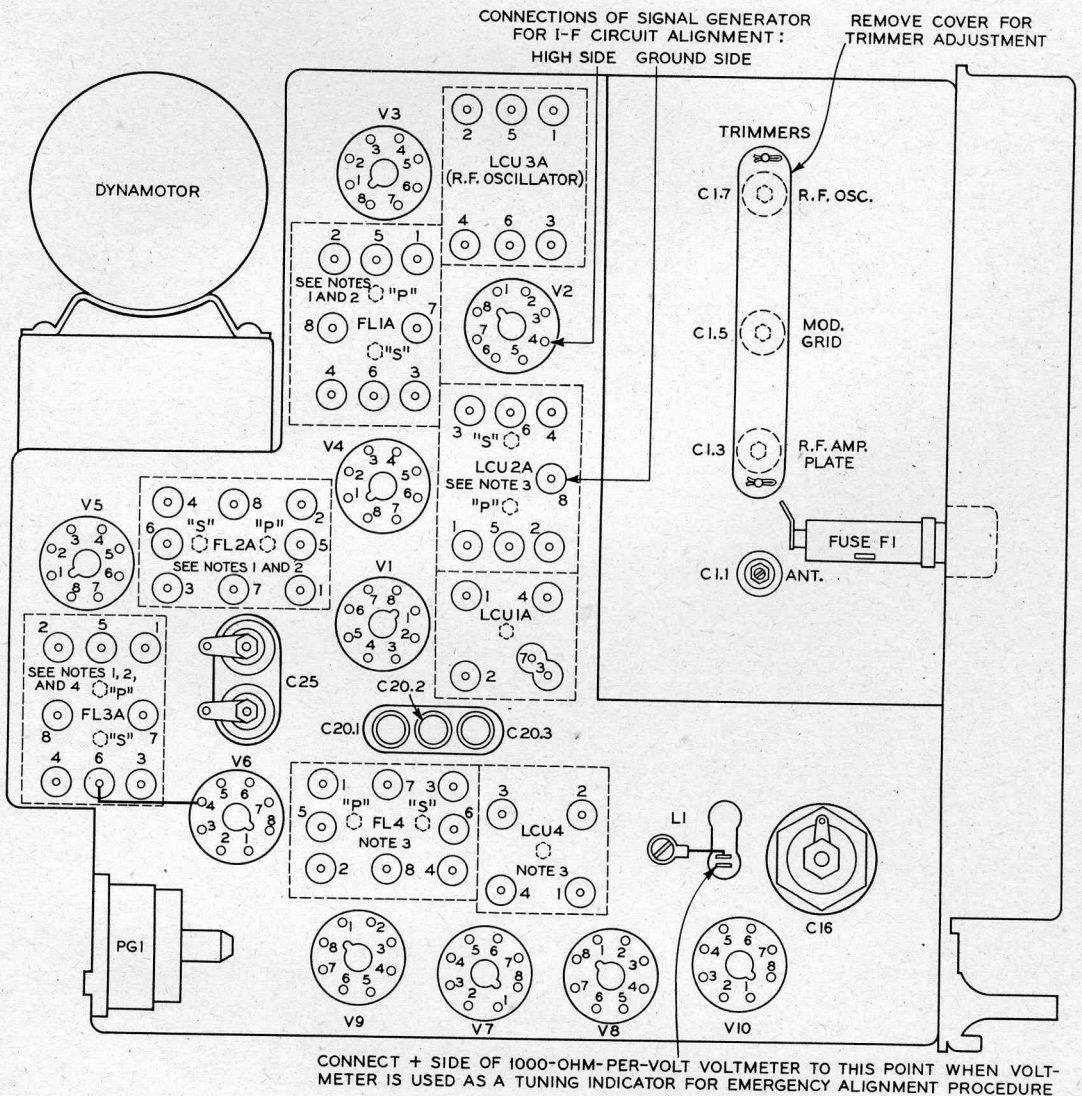

NOTES:

1. WHEN THE SHUNTING RESISTOR IS CONNECTED ACROSS TERMINALS 1 AND 2, ADJUST SCREW "S".
2. WHEN THE SHUNTING RESISTOR IS CONNECTED ACROSS TERMINALS 3 AND 4, ADJUST SCREW "P".
(THE ADJUSTING SCREWS REFERRED TO IN NOTES 1 AND 2 ARE ACCESSIBLE THROUGH THE TOP OF THE FILTER COVER ON THE OTHER SIDE OF THE CHASSIS, AND THE SHUNTING RESISTOR IS CONNECTED AS DESCRIBED IN PARAGRAPHS 34b, 34c, AND 37d).
3. ADJUSTING SCREWS ARE ACCESSIBLE THROUGH THE COVER ON THE OTHER SIDE OF THE CHASSIS.
4. CONNECT THE HIGH SIDE OF THE SIGNAL-GENERATOR OUTPUT TO TERMINAL 6 OF FL3 THROUGH A 0.006-MF MICA CAPACITOR FOR DISCRIMINATOR (FL4) ADJUSTMENT. CONNECT THE LOW SIDE OF THE SIGNAL GENERATOR TO CHASSIS.

Fig. 51. Radio Receiver BC-683-A: Location of Alignment and Tuning Controls

(l) Adjust the P (primary) and s (secondary) adjusting screws in tuning unit LCU2A and the single adjusting screw in LCU1A for maximum deflection of the voltmeter.

(m) Readjust the transmitter and receiver to the higher test frequency and trim C1.1, C1.3, and C1.5 for maximum voltmeter deflection.

(n) Check back and forth between the two test frequencies, repeating steps (l) and (m) until no further improvement can be made.

(o) Restore the receiver to normal and check the antenna trimmer capacitor as described in Paragraph 19a.

(6) *Emergency Alignment of Discriminator.* Align a discriminator filter unit (FL4) in an emergency as follows:

(a) Install the transmitter and the receiver in the mounting, with the receiver in the right-hand position.

(b) Connect the voltmeter (3-volt scale) across the limiter cathode choke, L1, as shown in Fig. 51.

(c) Disable the automatic-volume-control circuit by short-circuiting resistor R14. Use the short jumper wire with a clip on each end.

(d) Connect the 500-micromicrofarad capacitor between terminals 1 and 2 of filter unit FL2A. (The capacitor reduces the signal input to the intermediate-frequency amplifier sufficiently to prevent limiter action from masking the desired tuning point in the test.)

(e) Remove the cover plate from filter FL4.

(f) Turn the SPEAKER switch to ON, turn the TUNE-OPERATE switch to TUNE, and turn the SQUELCH switch to OFF. Turn the VOLUME control to the extreme right.

(g) Adjust the transmitter for operation near the 27-megacycle end of its frequency range and start the transmitter and the receiver. Place the transmitter in the RECEIVER TUNE condition.

(h) After the receiver has warmed up, carefully adjust the receiver tuning dial for zero-beat with the transmitter frequency. Observe that zero-beat occurs at maximum deflection of the

voltmeter and note the maximum reading.

(i) Remove the capacitor from FL2A and note the new voltmeter reading. The voltmeter reading with the capacitor connected to FL2A should not exceed three fourths of the reading with the capacitor removed. If it does, the capacitor leads are too long, or the clips are not making good contact.

(j) Reconnect the capacitor to terminals 1 and 2 of FL2A.

(k) Ground terminal 1 of FL4 to the chassis with a short jumper wire. Remove the voltmeter from across L1 and connect it between terminals 3 and 7 of filter FL4 (10-volt or 30-volt scale, + terminal to terminal 3 of the filter).

(l) Check the zero-beat setting of the dial while observing the voltmeter. The meter should read zero at zero-beat and reverse polarity as the receiver is tuned through the zero-beat point. If this is not the case, align the secondary by adjusting the s (secondary) adjusting screw for zero voltmeter reading.

(m) Remove the voltmeter from FL4 and connect it (3-volt scale) between terminals 2 and 3 of tuning unit LCU2A (+ terminal of voltmeter to terminal 3 of LCU2A). Remove the short circuit from resistor R14.

(n) Adjust the P (primary) screw in filter FL4 for a minimum deflection of the voltmeter.

(o) Reconnect the voltmeter (10-volt or 30-volt scale) to terminals 3 and 7 of FL4 and recheck the adjustment of screw s in FL4 as in step (l).

(p) Restore the receiver to normal.

35. Emergency Alignment of Radio Transmitter BC-684-A.

a. General. The test procedures described hereafter are intended to apply when it is necessary to replace one or more transmitter components which are likely to affect alignment of the transmitter tuned circuits and a precision wavemeter is not available for use. The critical components are: coils L101, L103A, L104, L105A, L106, L107, L108, and L110; the ganged adjustable capacitor assembly C106, C113, C115,

C119, C125, C152, and C156; and trimmer capacitors C107 (if used in the transmitter under test), C114, C116, C120, C126, C153, and C157. Replacement of capacitor C147 or the channel selector assembly also necessitates checking alignment of the circuits. The location of the alignment controls for the transmitter is shown in Fig. 52.

Note: During the following tests operate the dynamotor only when reading the meter or making an adjustment which requires power from the dynamotor. Paragraph 20*b* should be read and understood before the following or other servicing tests are made.

b. Testing Apparatus Required.

1—Narrow-blade ($\frac{1}{8}$ -inch) screwdriver or, preferably, a long-handled hexagon adjusting tool.

1—Rule (6-inches long x $\frac{3}{16}$ -inch wide).

c. Preliminary to Alignment. It is desirable to check the operation of the oscillator and metering circuits prior to emergency alignment of the transmitter circuits. This may be done as follows:

(1) Insert a low-numbered and a high-numbered crystal (preferably Channel 270 and Channel 389) in sockets numbered 1 and 10, respectively, in the crystal operating compartment.

(2) Set the METER SWITCH to position 2 (first radio-frequency amplifier grid current), turn the TUNE-ANT CUR switch to TUNE, and unlock the channel selector. This is described in Paragraph 21*a*.

(3) Press CHANNEL SELECTOR push button no. 1, start the transmitter, and operate the RECEIVER TUNE-OPERATE switch to RECEIVER TUNE.

(4) Observe the reading on the panel meter.

(5) Repeat steps (3) and (4) for push button no. 10. If meter readings are noted for both these frequencies the oscillator is operating properly.

d. Emergency Alignment of R-f Amplifier.

(1) In later transmitters C107 has been omitted, but if there is a C107 in the transmitter under test, see that it is set to the minimum capacitance position (open end of slot to left as viewed from the front of the transmitter).

(2) Press CHANNEL SELECTOR push-button no. 10. Set the METER SWITCH to position 3 (grid current of rectifier) and the RECEIVER TUNE-OPERATE switch to RECEIVER TUNE.

(3) Adjust the gang capacitor assembly for maximum deflection of the meter.

(4) Press push button no. 1 and repeat step (3).

(5) Carefully release push button no. 1, carefully turn the gang capacitor control to the extreme front, and lock the selector unit as also described in Paragraph 21*a*.

(6) Check the CHANNEL SELECTOR adjustments by pressing the no. 1 and no. 10 push buttons and observing the maximum meter deflection at each frequency as the gang capacitor assembly is rotated slightly against the restoring force of the selector. *Do not attempt to rotate the capacitor assembly more than a few degrees.* The test meter should indicate a maximum at the settings determined by the selector. If this is not the case, repeat steps (2) through (6) until you obtain the proper adjustment of the selector.

e. Emergency Alignment of Rectifier. Since the filters following the rectifier are primarily intended for selection of the correct crystal harmonic frequency, it is important that these circuits be disturbed as little as possible when replacing components which affect the alignment.

(1) If L118 or L119 has been replaced, adjust the tuning slugs to about $\frac{3}{4}$ inch from the open end of the coil as measured with the scale mentioned in Paragraph 35*b*.

(2) Set the METER SWITCH to position 4 (grid current of tripler).

(3) Start the transmitter at the high-frequency end of its range (by pressing the appropriate CHANNEL SELECTOR push button and

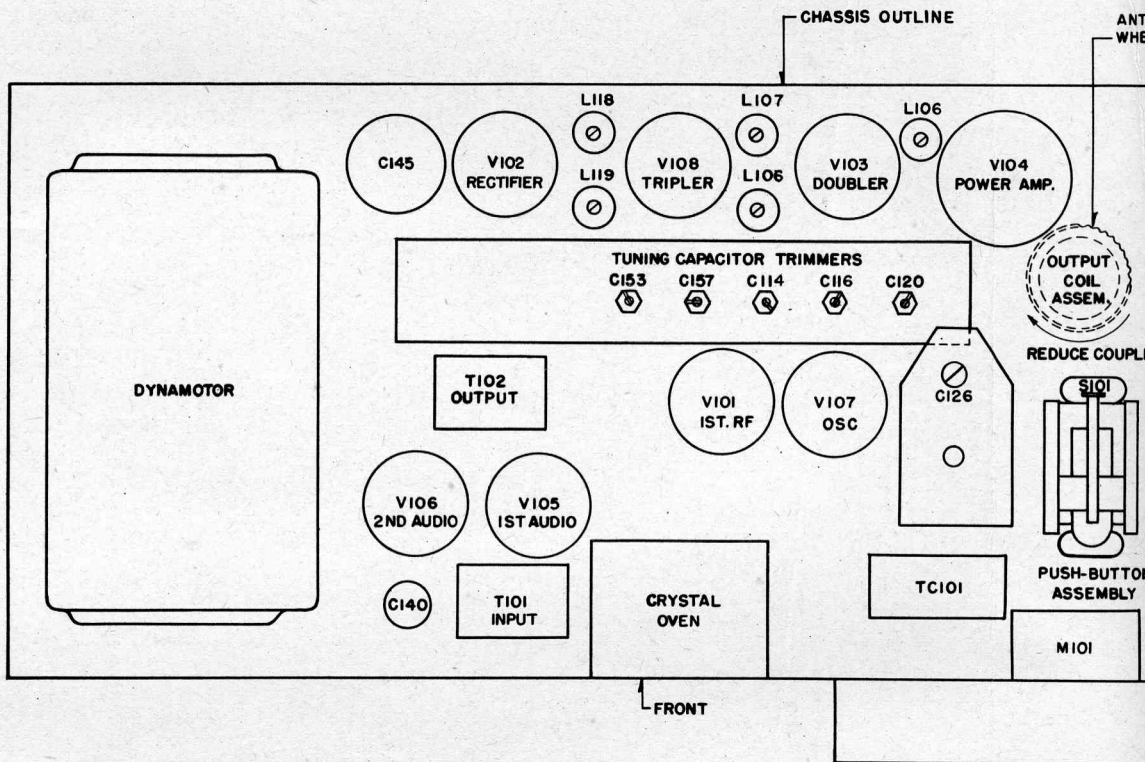

TOP VIEW OF TRANSMITTER, COVER REMOVED, SHOWING LOCATION OF GANGING ADJUSTMENTS AND TUNING

Fig. 52. Radio Transmitter BC-684-A: Location of A

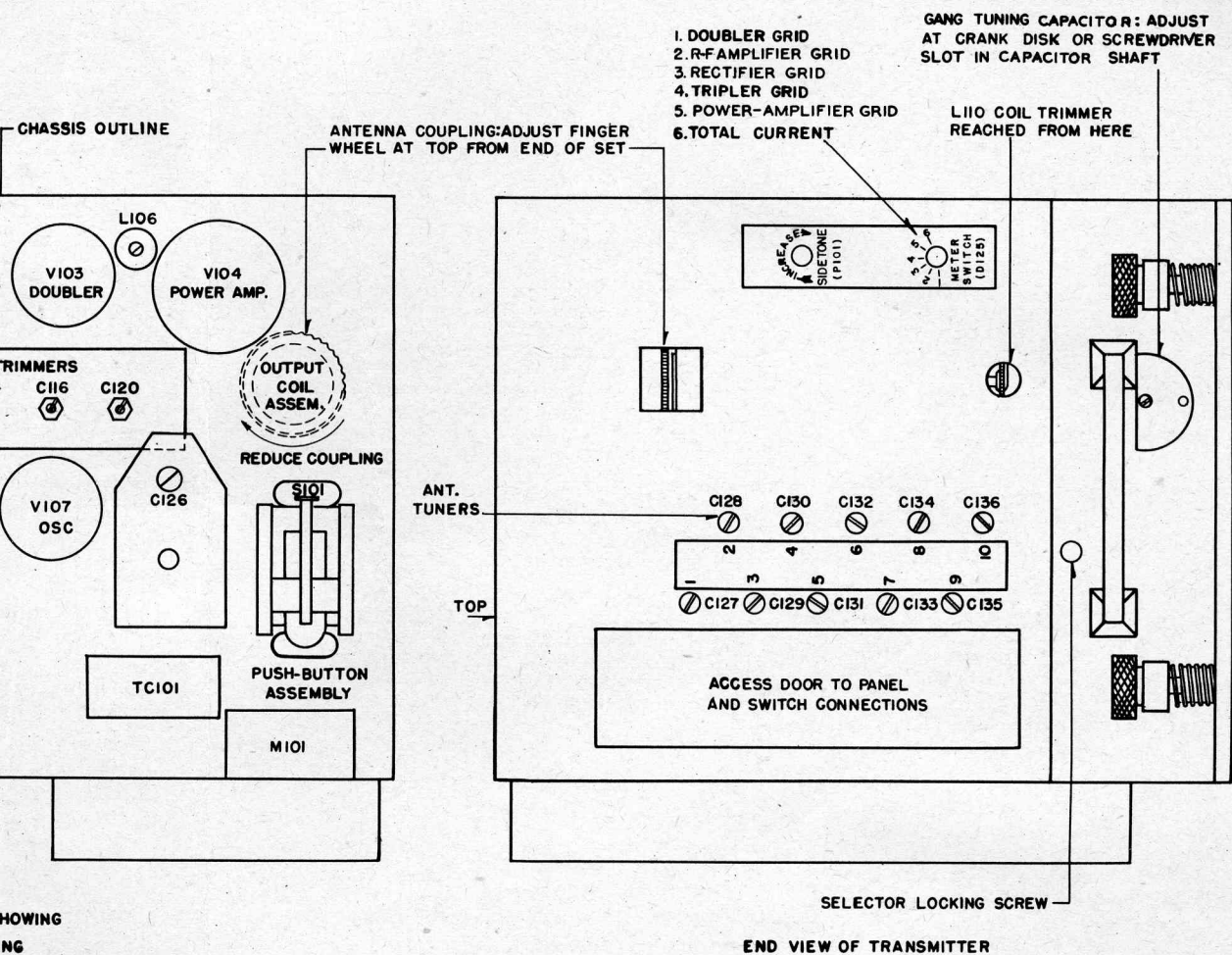

SHOWING
NG

Transmitter BC-684-A: Location of Alignment and Tuning Controls

throwing the RECEIVER TUNE-OPERATE switch to RECEIVER TUNE).

(4) Adjust C153 and C157, respectively, for maximum deflection of the meter.

(5) Adjust the transmitter to the low-frequency end of its range (by pressing the appropriate CHANNEL SELECTOR push button and throwing the RECEIVER TUNE-OPERATE switch to RECEIVER TUNE) and adjust L119 and L118, in turn, for maximum meter deflection.

(6) Repeat steps (3), (4), and (5) until no further increase in meter deflection can be obtained.

(7) Start a nearby receiver, throw the SPEAKER switch to ON, the TUNE-OPERATE switch to TUNE, and the SQUELCH switch to ON. Adjust the SENSITIVITY control so that the receiver is operated by only one frequency from the transmitter. This frequency, as determined from the receiver dial calibration, should be that for which the transmitter is tuned. If it is not, readjust the filter circuits but with a somewhat different initial setting of the tuning slugs in L118 and L119 until the receiver (used as a wavemeter) indicates that this stage has been aligned properly and the correct harmonic has been chosen by the L118, L119 and C153, C157 circuits.

f. Emergency Alignment of Tripler.

(1) If L106 or L107 has been replaced, adjust the tuning slugs to about three-fourths inch from the open end of the coil.

(2) Set the METER SWITCH to position 1 (grid current of doubler).

(3) Adjust the transmitter at the high-frequency end of its range. (See Paragraph 35c.)

(4) Adjust C114 and C116, in turn, for maximum deflection of the meter.

(5) Adjust the transmitter to the low-frequency end of its range and adjust L106 and L107 for maximum meter deflection.

(6) Repeat steps (3), (4), and (5) until no further increase in meter deflection is obtainable.

g. Emergency Alignment of Doubler.

(1) If L108 has been replaced, adjust the tuning slug to about $\frac{3}{4}$ inch from the open end of the coil.

(2) Set the METER SWITCH to position 5 (grid current of power amplifier).

(3) Adjust the transmitter at the high-frequency end of its range and adjust C120 for maximum meter deflection.

(4) Adjust the transmitter to the low-frequency end of its range and adjust L108 for maximum deflection of the meter.

(5) Repeat steps (3) and (4) until no further increase in meter deflection is possible.

b. Emergency Alignment of Power Amplifier.

(1) If the L110-L111 coil assembly has been replaced, adjust the tuning slug at the bottom of L110 to the center of its range of variation.

(2) Set the METER SWITCH to position 6 (total plate and screen current) and make sure the RECEIVER TUNE-OPERATE switch is at OPERATE and left there for the following power amplifier tests.

(3) Set for minimum coupling of L111 to L110 (rotation of the coupling control to the right). Detune C136 by setting it to the maximum capacitance position and detune C127 by adjusting it to the minimum capacitance position.

(4) Start the transmitter at the high-frequency end of its range. (For this test the dynamotor must be started by operating a microphone switch.) Adjust C126 for a *minimum* deflection of the meter. If a tuning point cannot be found, try a different setting of the L110 adjusting slug.

(5) Adjust the transmitter to the low-frequency end of its range. Adjust the slug in L110 for a *minimum* deflection of the meter. Adjust this slug by inserting a screwdriver through the hole in the end of the transmitter and turning the slug adjusting gear.

(6) Adjust C126 at the higher frequency and L110 at the lower frequency until no further reduction in the meter deflection can be made at either end.

36. **Emergency Sources of Test Tones.** In the absence of a test oscillator, test tones can be obtained from a receiver or a transmitter known to be in good condition. The methods of doing this are discussed in detail in Paragraph 39g(6) for the receiver and Paragraph 39g(7) for the transmitter. Signal sources other than a signal generator may be summarized as follows:

a. A-f Signal.

(1) A good receiver will provide audio-frequency noise when there is no input signal.

(2) If two good receivers are available they can be used together to provide a beat note.

(3) A good transmitter may be used with a microphone into which the operator hums or whistles. The resulting audio output can be picked up for test purposes.

b. I-f Signal. This may be obtained from a good receiver.

c. R-f Signal. This may be obtained from either a receiver or a transmitter.

d. Atmospheric Noise. Atmospheric noise may be used as a signal source in the absence of other signal source. Since noise is an indefinite sort of signal (no precise frequency) and the intermediate-frequency band width is considerably wider than the range of frequency which may be heard, the number of circuits aligned by this means should be a minimum.

e. Signals from Distant Vehicle. Signals from a vehicle about 10 miles distant may be used as a rough check of receiver sensitivity, particularly when such signals are compared to the noise background when the distant transmitter is off the air.

f. Signals from Nearby Vehicle. Signals from a nearby vehicle which is operating into

Antenna A-83 (phantom), or the antenna shown in Fig. 77, or a 40-watt Mazda lamp, instead of the regular antenna structure, are strong enough for testing purposes.

37. **Precision Alignment of Radio Receiver BC-683-A.**

a. General. Whenever a complete inspection of a receiver is made, check alignment of the tuned circuits in accordance with the following procedure:

b. Testing Apparatus Required.

1—Adapter FT-384-(*).

1—Insulated 1/4-inch hexagon socket wrench.

1—Output meter from Test Set I-56-(*), or its equivalent.

1—Volt-ohmmeter I-107-(*), or its equivalent.

1—Signal generator (frequency-modulated).

1—Cornell-Dubilier capacitor, Type 1W, 0.006-microfarad, or its equivalent, with suitable clips.

1—IRC resistor, Type BT-1/2, 1000 ohms, or its equivalent, equipped with insulated clip connectors.

Caution: When connecting or disconnecting these wires, turn the receiver off each time to avoid shocks.

Adapter FT-384-(*) is a switching box for connecting test meters in various parts of the circuit to facilitate alignment procedure. Photographs and a circuit diagram are shown in the following figures:

Fig. 53. Adapter FT-384-(*): Front View.

Fig. 54. Adapter FT-384-(*): Back View.

Fig. 55. Adapter FT-384-(*): Application to Radio Receiver BC-683-A.

Fig. 56. Adapter FT-384-(*): Schematic and Wiring Diagram.

c. Alignment of Discriminator Circuit (FL4) and I-f Oscillator Circuit (LCU4). When aligning the intermediate-frequency amplifier or discriminator, if no shielded room is

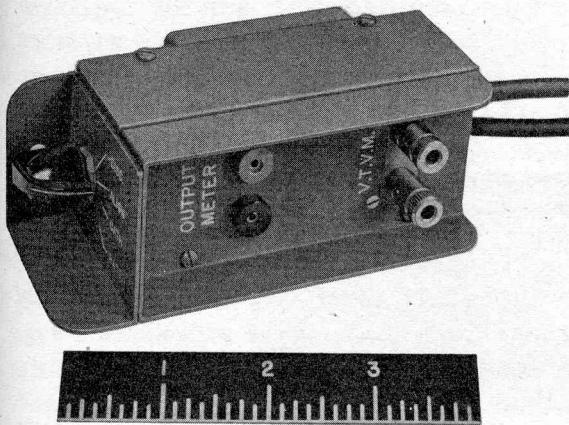

Fig. 53. Adapter FT-384-(*): Front View

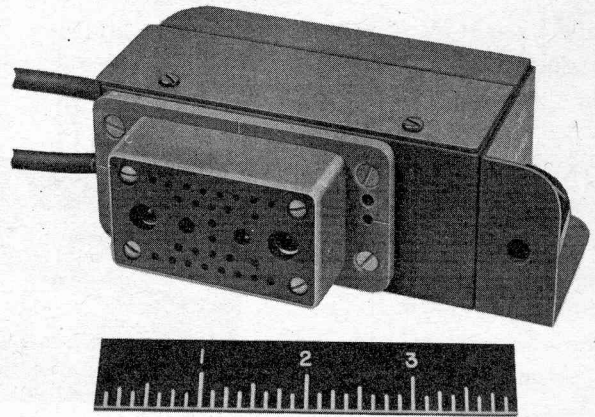

Fig. 54. Adapter FT-384-(*): Back View

available and disturbing interference from nearby electrical equipment is observed, this interference can be minimized by connecting a short strap lead from terminal 5 of V3 to C25 (the terminal to which blue-tracer wires are connected), whenever using the intermediate frequency.

(1) Remove the dust cover from the receiver.

(2) Make sure that a dynamotor of the correct primary voltage rating is in place.

(3) Loosen the cover plates from LCU1A, LCU2A, FL1A, FL2A, FL3A, FL4, and LCU4. (The plates may be loosened by removing the cotter pin at one end.)

Caution: Do not remove the cover from LCU3A.

(4) Set the receiver controls as follows: The **SPEAKER** switch at **ON**, the **SENSITIVITY** and **VOLUME** controls to the extreme right, the **TUNE-OPERATE** switch at **OPERATE**, the **REC** switch at **OFF** until ready, the **OUTPUT TO PHONES** switch at **ON**, and the **SQUELCH** switch at **OFF**.

(5) Set up Volt-ohmmeter I-107-(*) as follows: Connect the battery plug attached to the short cable at the bottom of the volt-ohmmeter to a Battery BA-40. Set the **SELECTOR** switch for **-VOLTS** and the **RANGE** switch for **3 V.D.C.** Short the **COMMON** and **D.C. VOLTS** leads together and turn the **ZERO ADJ** knob for zero indication on the meter. It is advisable to leave Volt-ohmmeter

I-107-(*) on for approximately five minutes before using it, to allow the zero adjustment of the meter to become stable. Connect the volt-ohmmeter leads to the v.t.v.m. posts of Adapter FT-384-(*).

(6) Connect the high side of the signal generator output through the 0.006-microfarad capacitor to the limiter control grid (terminal 6 of FL3A) and connect the low side of the generator to the chassis.

(7) Adjust the generator for an output of between 1.0 and 2 volts at 2.65 megacycles.

(8) Plug Adapter FT-384-(*) into receptacle PG1 of the receiver and connect to the battery. Turn the switch of the adapter to **DISC** (discriminator output voltage).

(9) Turn the receiver to **ON** and, after allowing sufficient time for the vacuum tubes to heat, adjust screw **s** (secondary) in filter FL4 for zero current in the voltmeter. The meter should reverse polarity as **s** is varied to either side of the zero-current point. The selector switch of Volt-ohmmeter I-107-(*) can be turned from **-VOLTS** to **+VOLTS** to note this effect. This is an accurate indication of frequency and can be used as a check during the test. A check may be made from time to time to make sure that this meter still reads zero. If it does not, the signal generator should be readjusted to restore the reading to zero.

(10) Throw the **TUNE-OPERATE** switch to **TUNE**. Adjust the slug in tuning unit LCU4 for

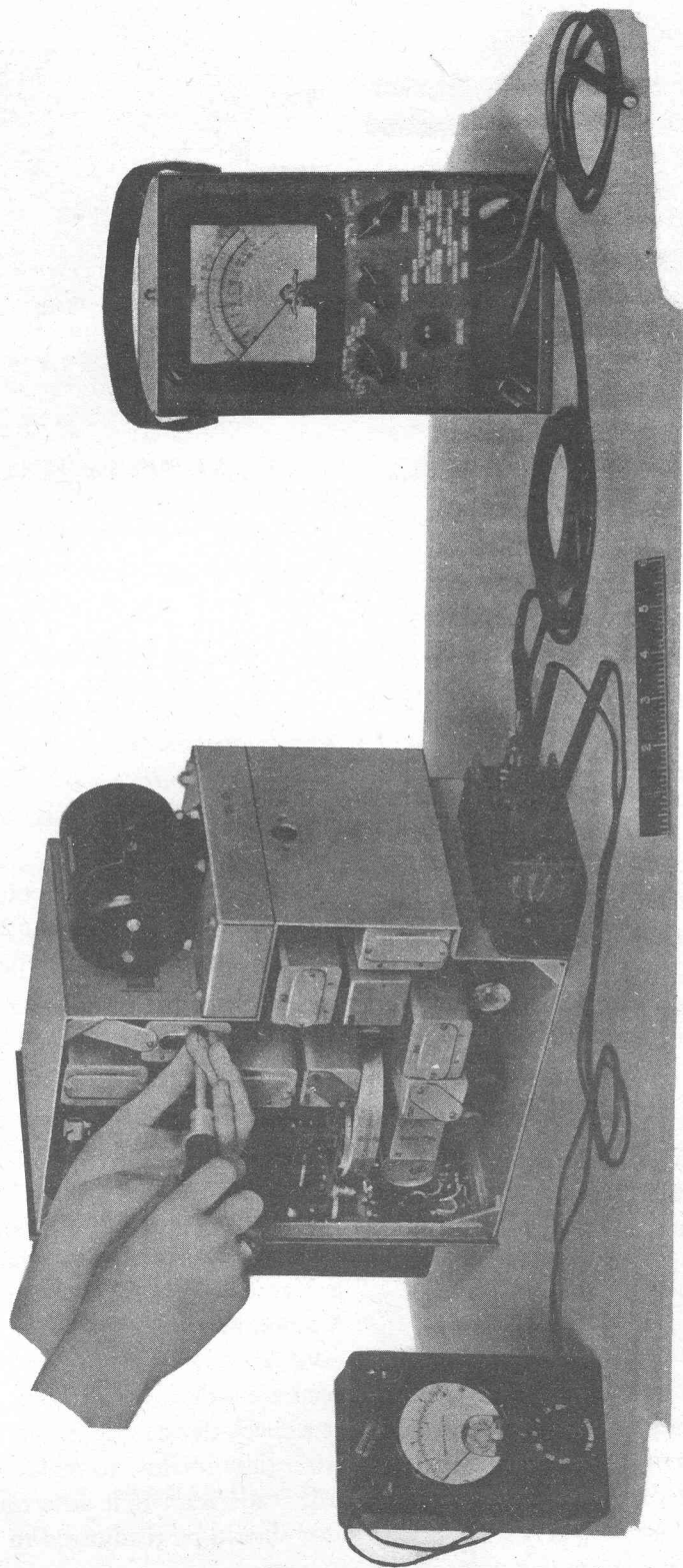

Fig. 55. Adapter FT-384-(*): Application to Radio Receiver BC-683-A

zero-beat. Set the TUNE-OPERATE switch to OPERATE.

(11) Turn the switch of the adapter to ALIGN and adjust the P (primary) adjusting screw in FL4 for maximum indication on the volt-ohmmeter.

(12) Restore the adapter switch to DISC and trim the s screw setting for zero meter current. Adjust the signal generator 50 kilocycles above and 50 kilocycles below 2.65 megacycles and make sure that the readings of the volt-ohmmeter are approximately the same (but of opposite polarity).

(13) Vary the signal generator frequency above 2.65 megacycles until the test meter deflection is greatest. Note the meter reading and the generator frequency. The frequency should be between 2.725 and 2.745 megacycles.

(14) Repeat step (13) below 2.65 megacycles. The meter reading should be within 0.75 volt of the previous reading and the frequency should be between 2.560 and 2.580 megacycles.

(15) Place the switch of the adapter at CATH, with the signal generator set for 1.0-volt output at 2.65 megacycles and note the reading of the volt-ohmmeter for later use in testing the intermediate-frequency amplifier.

d. Alignment of I-f Amplifier.

(1) Reduce the signal generator output to zero and connect its shielded cord to the control grid of the modulator (terminal 4 of V2). Exposed unshielded wires are dangerous and should be kept as short as possible, preferably less than 2 inches, including the clip.

(2) Adjust the generator to a small output at 2.65 megacycles and adjust it for zero-beat with the intermediate-frequency oscillator when the TUNE-OPERATE switch is set at TUNE. Then restore the switch to OPERATE.

(3) With the switch of the adapter at CATH, increase the generator output sufficiently to cause a reading of 0.9 on the volt-ohmmeter. Adjust the generator output from time to time during the following alignment to maintain a meter reading of between 0.6 and 0.9 volt.

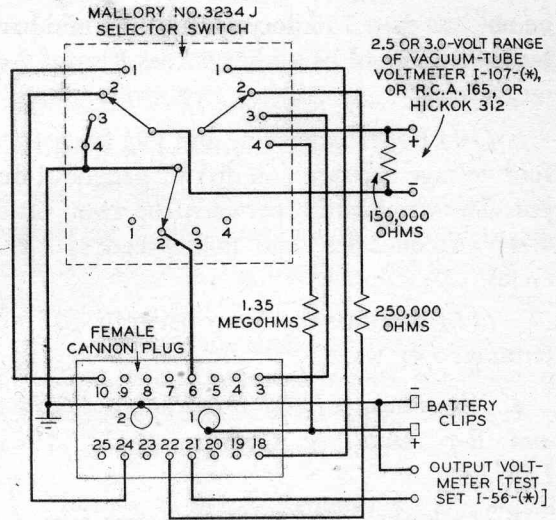

Fig. 56. Adapter FT-384-(*): Schematic and Wiring Diagram

(4) Connect the 1000-ohm resistor between terminals 3 and 4 of filter unit FL3A and adjust the primary of FL3A designated P, for maximum voltmeter reading.

(5) Connect the resistor between terminals 1 and 2 of FL3A and tune the secondary of FL3A, designated s, for maximum voltmeter indication.

(6) Repeat steps (4) and (5) for filter units FL2A and FL1A, respectively. Upon completion of these adjustments, note the signal generator output required to obtain the same meter deflection as in Paragraph 37c(15). It should not be necessary to increase the signal generator output beyond 50 microvolts to obtain this reading.

(7) Vary the signal generator frequency through the 2.65-megacycle setting and note that the selectivity is approximately symmetrical about the mid-frequency.

(8) Adjust the generator frequency to 2.65 megacycles and the generator output as required for a meter current of 0.9 volt.

(9) Double the signal generator output voltage (6 db increase) and determine the frequencies above and below 2.65 megacycles at which 0.9 volt is obtained. The band width between the two "6 db down" frequencies should

be not less than 75 kilocycles and the mid-band frequency should be within 5 kilocycles of 2.65 megacycles.

(10) Repeat steps (8) and (9) for a 1000-fold voltage increase (60 db) of generator output. The band width between the two "60 db down" frequencies shall not exceed 350 kilocycles.

(11) Remove the strap between C25 and terminal 5 of V3.

e. Alignment of R-f Oscillator (LCU3A) and R-f Amplifier Circuits (LCU1A and LCU2A).

(1) Reduce the signal-generator output to zero and connect its shielded output cord directly to the A and G binding posts on the receiver, with short leads. (This will be a test through the whole receiver except the connections from the front A and G binding posts to the regular A and G terminals in the plug PG1. It may be wise, therefore, to test for continuity between these two sets of terminals.)

(2) Rotate the tuning dial to the stop at the 27-megacycle end of the scale. The reference line on the dial should be in approximate alignment with the tuning index. If the error is $\frac{1}{8}$ inch or more, repair the unit. This involves removing the front panel and adjusting the glass with the hairline on it. It should be done only if unavoidable.

(3) Adjust the dial and the signal generator to 39 megacycles.

(4) Loosen the cover plate (near C24) from C1.3, C1.5, and C1.7 and the cover plate of LCU3A.

(5) Turn the switch of Adapter FT-384-(*) TO DISC.

(6) Place the TUNE-OPERATE switch of the receiver at TUNE.

(7) Adjust the trimmer C1.7 for zero-beat in the loudspeaker. The (discriminator) voltmeter should read zero when the frequency is correct. This is an additional check on the frequency of the intermediate-frequency oscillator.

(8) Set the signal generator and the receiver

dial at 27 megacycles and adjust the slug in LCU3A for zero-beat.

(9) Repeat steps (7) and (8) until the oscillator tracks satisfactorily at both ends of the band.

(10) When the oscillator is satisfactory at both ends of the band, check the 36-, 33-, and 30-megacycle points also. Zero-beat should be obtained within one-half dial division at each of these frequencies. If tracking at these frequencies is not satisfactory repeat step (7) using 38 megacycles and step (8) using 28 megacycles. After the dial tracking is regarded as satisfactory, take care to avoid touching C1.7 and the slug of LCU3A, when making further adjustments.

(11) Turn the switch of Adapter FT-384-(*) TO CATHODE and restore the TUNE-OPERATE switch to OPERATE.

(12) Increase the signal generator output sufficiently to cause a meter reading of 0.9 volt. Adjust the generator during the course of the following procedure to maintain a reading of between 0.6 and 0.9 volt on the meter.

Note: During the final alignment adjustments it is usually impossible to keep the meter deflection below 0.9 volt by reducing generator output. Under these conditions modulate the generator with 400 cycles and a frequency swing of ± 15 kilocycles. Connect the output meter of Test Set I-56-(*) to Adapter FT-384-(*), and supplement the test meter deflection by observing the output meter deflection.

(13) With the signal generator at 39 megacycles, tune the receiver dial for zero-beat at 39 megacycles. Adjust, in turn, trimmer capacitors C1.5, C1.3, and C1.1 for maximum test meter deflection.

(14) Adjust the generator and the receiver to 27 megacycles as in step (13).

(15) Adjust, in turn, the slugs in the LCU1A and LCU2A shield cans for maximum deflection of the meter.

(16) Readjust the trimmer capacitors at 39 megacycles and the inductance trimmers at 27 megacycles alternately until no further improvement can be obtained.

f. Check of Sensitivity and Stability.

(1) Set the signal generator to 39 megacycles and adjust the receiver to zero-beat at 39 megacycles. Then reduce the signal generator to zero output.

(2) Switch the SQUELCH control to ON and adjust the SENSITIVITY control so that the CALL SIGNAL lamp is *barely* extinguished.

(3) Increase the generator output sufficiently to illuminate the CALL SIGNAL lamp. A signal of 1.0 microvolt or less should suffice.

(4) Repeat steps (2) and (3) at 27 megacycles.

(5) Set the signal generator to give 3 microvolts output at 39 megacycles. It should be possible to extinguish the CALL SIGNAL lamp by turning the SENSITIVITY control to the left. Repeat this test at 27 megacycles.

(6) Throw the TUNE-OPERATE switch to TUNE and adjust the tuning dial for a low-pitched beat note.

(7) Vary the signal-generator output from about 1.0 to 1000 microvolts. The pitch of the beat note should remain within audibility over the entire range of signal voltage.

g. Output Power Measurement.

(1) Adjust the signal-generator frequency to 27 megacycles and 1.0-microvolt output.

(2) With the SPEAKER switch at ON, and the TUNE-OPERATE switch at TUNE, set the OUTPUT TO PHONES switch to ON, and the SQUELCH switch to ON. Turn the SENSITIVITY and VOLUME controls to the extreme right.

(3) Tune to zero beat with the signal generator and operate the TUNE-OPERATE switch to OPERATE. Turn the SPEAKER switch to OFF.

(4) Modulate the signal generator with 400 cycles with a frequency deviation of 15 kilocycles and read the output meter. The meter should read over 18 volts.

b. Noise Test. With the signal-generator output at 1.0 microvolt, remove the modulation

from the signal. The output meter should not read more than one fifth of the reading obtained in Paragraph 37g(5).

i. Check of Limiter Action.

(1) With conditions as in Paragraph 37g, increase the signal-generator output to 10 microvolts and observe the reading of the output meter.

(2) Increase the signal-generator output to 100, 1000, and 10,000 microvolts successively. The voltmeter reading should stay within ± 5 volts of the reading obtained in (1).

j. Volume Control. Remodulate the signal with 400 cycles with a frequency deviation of 15 kilocycles and 1.0-microvolt input, and gradually rotate the VOLUME control to the left. The output meter should decrease progressively to less than 1.0 volt. After restoring the volume to maximum, turn the SPEAKER switch to ON. The output meter reading should remain approximately constant. Observe the tone from the loudspeaker as a check on its operation. A very weak response or a bad rattle may indicate that the speaker cone has been damaged.

38. Precision Alignment of Radio Transmitter BC-684-A.

a. General. Whenever a complete inspection of a transmitter is made, check alignment of the tuned circuits as follows:

b. Testing Equipment Required.

1—Antenna A-83 (phantom), or an artificial antenna (Fig. 77), or, if radiation is permissible, a vehicle antenna of correct dimensions (including lead-in and ground).

1—Sensitive precision wavemeter, 4- to 20-megacycle range.

1—Narrow-blade ($1/8$ -inch) screwdriver or long-handled hexagon socket wrench for adjusting the trimmer capacitors and coil slugs.

1— $3/8$ -inch screwdriver for locking the selector, etc.

1—6-inch rule (narrow blade).

1—Cord CD-786 for connection of the transmitter under test to the power supply through a convenient mounting or equivalent.

c. Preliminary to Alignment.

(1) Throw the TRANSMITTER switch to OFF, the RECEIVER TUNE-OPERATE switch to OPERATE, and the TUNE-ANT CUR switch to TUNE.

(2) Insert Crystal Holder FT-241-A, Channel 270, into socket no. 1 and Crystal Holder FT-241-A, Channel 389, into socket no. 10 in the crystal operating compartment. If these particular crystals are unavailable, others within five channels of these may be used.

(3) Remove the top and bottom cover plates from the transmitter and lay the transmitter on its back so the bottom and top sections are accessible. Plug one end of Cord CD-786 into the left end of the transmitter and the other end into the left connector of the mounting which is connected to a large 12- or 24-volt battery supply. Make sure a dynamotor of the correct input voltage rating has been inserted in the transmitter.

(4) Unlock the channel selector (see Paragraph 21a) and then set the gang capacitor for minimum capacitance (plates all out).

d. Alignment of First R-f Amplifier.

(1) Set the METER SWITCH to position 2 (grid current in the first radio-frequency amplifier) and turn the TRANSMITTER switch to ON.

(2) Set C107 to the minimum capacitance position (open end of slot at left as viewed from front of the transmitter).

Note: Capacitor C107 has been omitted from later transmitters.

(3) Press push button no. 10 and start the dynamotor by placing the RECEIVER TUNE-OPERATE switch on RECEIVER TUNE. If the oscillator and metering circuit are working, the meter will deflect, indicating current in the first radio-frequency amplifier grid circuit. Stop the dynamotor by throwing the RECEIVER TUNE-OPERATE switch to OPERATE. Do not let the dynamotor run for long periods of time during the following tests.

(4) Set the METER SWITCH to position 3 (grid current in rectifier).

(5) Start the dynamotor (RECEIVER TUNE-OPERATE switch to RECEIVER TUNE). Adjust the gang capacitor for maximum meter deflection and observe the relative position of the capacitor plates. Rotate the gang capacitor by inserting a screwdriver in the slot on the end of the gang capacitor shaft (located near the handle on the right end of the transmitter) or by the associated small knob.

(6) Press push button no. 1 and repeat step (5). The observed rotation of the gang capacitor in passing from no. 10 to no. 1 should be at least 75 per cent of the total possible rotation.

(7) Carefully release push button no. 1, turn the gang capacitor to the extreme right, and lock the selector unit.

(8) Start the transmitter (dynamotor). Check the selector adjustment by pressing the no. 1 and then the no. 10 push button. Observe the maximum meter deflection at each frequency as the gang capacitor is varied slightly against the restoring force of the selector springs. *Do not attempt to rotate the capacitor control more than a few degrees.* The meter should indicate a maximum deflection at the capacitor setting determined by the selector. If the gang capacitor has not been properly positioned at each frequency, repeat the procedure, Paragraphs (5) through (8), until the proper adjustment is obtained or the trouble is located.

e. Alignment of Rectifier.

(1) Set the METER SWITCH to position 4 (grid current in tripler).

(2) Adjust the tuning slugs in L119 and L118 to about $\frac{3}{4}$ inch from the open end of the coils. This may be measured with the 6-inch narrow blade rule inserted in the open end of the coil form.

(3) Set C153 and C157 to the mid-capacitance position (open end of slot toward rear of set).

Note: Steps *e*(2) and *e*(3) are unnecessary if there is reason to believe that there has been no major change in the coils or capacitors in this stage.

(4) Adjust the wavemeter to one sixth of the output frequency ($38.9/6 = 6.48$ megacycles) and place the pickup coil near L118 and L119.

Caution: The wavemeter may affect the tuning of L118 and L119 if it is coupled too closely to these coils.

(5) Press push button no. 10, start the dynamotor, and adjust C153 and C157 for a maximum deflection of the transmitter panel meter at the wavemeter frequency. *Take care that the circuits are being tuned to the correct frequency.* Wavemeter resonance is indicated by a dip in panel meter reading. If the circuits cannot be tuned, try a different setting of the L119 and L118 tuning slugs. Repeat this procedure until a panel meter deflection is obtained, and with the wavemeter determine the frequency to which the circuits are tuned. If the tuned frequency is higher than the correct frequency, increase the tuning inductance or capacity, or both; if the tuned frequency is lower than the correct frequency, decrease the tuning inductance or capacity, or both, until the correct frequency is obtained. The transmitter employs copper tuning slugs in the coils and, therefore, the coil inductance is decreased as the slug is inserted farther into the coil winding.

(6) Press push button no. 1 and adjust the slugs in L119 and L118, respectively, for maximum deflection of the panel meter. Do not adjust C153 and C157. Check the frequency being tuned ($27.0/6 = 4.50$ megacycles) with the wavemeter and proceed as in step (5) if the frequency is incorrect.

(7) Repeat step (5) (adjusting only the capacitance trimmers on button 10) and step (6) (adjusting only the coil slugs on button 1) until no further adjustment is required. In some cases where the circuits do not appear to align

properly at both ends of the band it may be desirable (with the METER SWITCH in position 3) to adjust and lock selector button 5 at some frequency near the middle of the band (say 33 megacycles) and align between buttons 10 and 5 to get the coil slugs and capacitors near their correct positions. Then finally align between buttons 10 and 1 as described.

f. Alignment of Tripler.

(1) Set the METER SWITCH to position 1 (grid current in doubler).

(2) Adjust the tuning slugs in L106 and L107 to about $3/4$ inch from the open end of the coils.

(3) Set C114 and C116 to the mid-capacitance position (open end of slot toward rear of set).

Note: Steps *f*(2) and *f*(3) are unnecessary if there has been no major change in the coils or capacitors in this stage.

(4) Adjust the wavemeter to one half of the output frequency ($38.9/2 = 19.45$ megacycles) and place the pickup coil near L106 and L107.

(5) Press push button no. 10, start the dynamotor, and adjust C114 and C116 for a maximum deflection of the panel meter at the wavemeter frequency. *Take care that the circuits are being tuned to 19.45 megacycles.* If the circuits cannot be tuned to the proper frequency, try a different setting of the L106 and L107 tuning slugs.

(6) Depress push button no. 1 and adjust the slugs in L106 and L107 for maximum deflection of the meter. Check the frequency being tuned ($27.0/2 = 13.5$ megacycles) with the wavemeter. If the frequency is incorrect, it will be necessary to recheck the frequencies to which the rectifier stage has been aligned in accordance with Paragraphs 38*e*(4) and 38*e*(6).

(7) Repeat step (5) (adjusting only the capacitance trimmers on button 10) and step (6) (adjusting only the coil slugs on button 1) until no further adjustment is required.

g. Alignment of Doubler.

(1) Set the METER SWITCH to position 5 (grid current in power amplifier).

(2) Adjust the tuning slug in L108 to about $\frac{3}{4}$ inch from the open end of the coil.

Note: This step is unnecessary if there has been no major change in the coil or capacitor in this stage.

(3) Press push button no. 10, start the dynamotor, and adjust C120 for a maximum deflection of the meter. If a tuning point cannot be found, try a different setting of the L108 tuning slug. Frequency measurements are not required in this stage if the alignment of the preceding circuits has been done correctly.

(4) Press push button no. 1 and adjust the slug in L108 for a maximum meter deflection.

(5) Repeat step (3) (adjusting only C120 on button 10), and step (4) (adjusting only L108 on button 1), until no further adjustment is required.

(6) Replace the bottom cover plate of the transmitter and trim all alignment adjustments previously made, by repeating the procedure described in Paragraphs 38*d*, *e*, *f*, and *g*. The bottom cover makes only small changes in the circuit capacitances or inductances and so only small changes in the trimmer capacitors or coil slugs will be required. They are necessary, however, if most satisfactory performance and tube life are to be obtained.

b. Alignment of Power Amplifier.

(1) Set the METER SWITCH to position 6 (total plate current).

(2) Throw the RECEIVER TUNE-OPERATE switch to OPERATE.

(3) Adjust the coupling of L111 to L110 until the center of coil L111 is opposite the top of coil L110 as seen through the vertical slot in L110. This may be accomplished by rotation of the knurled finger wheel accessible through a rectangular hole in the right end panel. (See Fig. 52.)

(4) Connect an antenna (artificial or real; see Paragraph 38*b*) to the transmitter. (During manufacture this stage is adjusted with the artificial antenna (Fig. 77) plugged into the A and G posts on the front panel of the transmitter.)

(5) Press push button no. 10, plug in a microphone, and start the dynamotor by operating the microphone switch. Immediately adjust C126 on top of the selector unit for minimum deflection of the panel meter (minimum plate current).

(6) Adjust antenna trimmer capacitor C136 (marked as no. 10 on the right-end panel of the transmitter) for maximum antenna current in the artificial antenna meter.

Note: If an Antenna A-83 (phantom) or a real antenna is used for these coupling adjustments it will be necessary, in order to have an indication of antenna current, to throw the TUNE-ANT CUR switch to ANT CUR and observe the deflection of the panel meter. Restore the TUNE-ANT CUR switch to the TUNE position whenever adjustments are to be made to capacitor C126 or to the inductance trimmer of L110.

(7) Adjust the coupling between L110 and L111 for maximum antenna current, then reduce the coupling to lower the antenna current to approximately 60 per cent of maximum and readjust the antenna capacitor, C136, for maximum antenna current.

(8) Press selector button no. 1 and adjust the tuning slug (inductance trimmer) of L110 for *minimum* plate current (with the TUNE-ANT CUR switch at TUNE). The tuning slug is operated by a toothed wheel which is turned by inserting a screwdriver through the hole opposite the bottom of L110 in the right-end panel of the transmitter.

(9) Adjust the antenna trimmer, C127 (no. 1), for maximum antenna current.

(10) Shift alternately between selector buttons no. 1 and no. 10, making the proper adjustment of L110 and C126 for minimum plate current until no further adjustment of L110 and

C126 is required. When on button no. 1, adjust the tuning slug L110 for *minimum* plate current, and adjust the antenna trimmer, C127, for *maximum* antenna current. When on button no. 10, adjust the trimmer capacitor, C126, for *minimum* plate current and adjust the antenna trimmer, C136, for *maximum* antenna current.

As the minimum meter reading may not be sharply defined when the inductance trimmer is turned, it is sometimes easier to adjust the capacity trimmer C126 for *minimum* plate current when on selector button no. 10, then operate selector button no. 1, and again adjust C126 for *minimum* plate current. Then adjust the inductance trimmer by a few turns and repeat the procedure already outlined, noting the position of C126 for each selector button. Turn the inductance trimmer of L110 one way or the other until the position of C126 for *minimum* plate current is the same at both ends of the band (selector buttons 1 and 10).

The radio-frequency stages have now been ganged and should track satisfactorily at all frequencies.

i. Coupling to the Antenna Circuit. When the procedure in Paragraph 38*b* has been properly accomplished, the transmitter is ready for coupling to a suitable antenna. The method of making coupling adjustments is described in Paragraph 21*a*.

39. Location of Trouble in Radio Receiver BC-683-A.

a. General. The following tests aid in isolating the source of trouble. *To be effective the procedure should be followed in the order given here.* A faulty receiver will be referred to hereafter as the "trouble" receiver.

Refer to the following figures to aid in the locating of trouble in the receiver:

- Figs. 44-46. Apparatus Location Diagrams.
- Fig. 51. Location of Alignment and Tuning Controls.
- Fig. 57. Voltage Diagram.
- Fig. 58. Resistance Diagram.
- Figs. 43, 72. Wiring Diagrams.

Remember first, servicing procedure should cause no further injury to the receiver. Second, trouble should be localized to a single stage or circuit. Third, the trouble may then be isolated within that stage or circuit by appropriate voltage, resistance, and continuity measurements. The relationship of the various steps of this suggested procedure to these considerations, graphically illustrated in Charts 2 and 3 at the end of Paragraph 39, may be summarized as follows:

The purpose of inspection is to locate any visible trouble. Through this inspection alone, you may frequently discover the trouble, or determine the stage in which the trouble exists. This inspection is valuable in avoiding additional damage to the receiver which might occur through improper servicing methods, and in forestalling future failures.

The power supply test prevents further damage to the receiver or the dynamotor from certain possible short circuits. Since this test gives an indication of the operation of the dynamotor and filter circuits, its function is not merely preventive.

The operational test is important as it frequently indicates the general location of the trouble. In many instances the information gained will determine the exact nature of the fault. To utilize this information fully, interpret all symptoms in relation to each other.

The principal advantage of the signal tracing method is that it usually enables you to localize a trouble accurately and quickly to a given stage when the general location of this trouble is not immediately evident from the above tests.

In all these tests the possibility of intermittents should not be overlooked. If present, this type of trouble may be made to appear in most cases by tapping or jarring the set. It is possible that no trouble will be found in the receiver itself but that the trouble is in the installation (mounting, interphone system, or vehicle), or, possibly, is due to external conditions. In this event, test the installation, if possible.

b. General Precautions. Whenever a receiver is to be serviced, observe the following general precautions very carefully.

(1) With the cover removed, dangerous voltages are exposed when the set is operating.

(2) Whenever a receiver is suspected of being in trouble, make the inspection and power supply test. Be sure to remedy the cause of any abnormal heating before continuing the procedure.

(3) Don't allow the dynamotor to run for any appreciable period of time at the start of the inspection until you are sure there are no short circuits which will cause burning of receiver parts.

(4) When making resistance and continuity measurements, first remove the power plug *and* dynamotor.

(5) Don't remove the shield can of the tuned units (LCU or FL) from any unit unless you definitely know that trouble exists within that unit. Whenever one part of the tuned circuit is replaced, realign the unit.

(6) Whenever you suspect intermittent trouble, make a thorough check of wiring and parts. In many cases you can make intermittent troubles appear by jarring the receiver.

(7) Take care, when inspecting wiring and soldered connections, not to damage the insulation. Don't leave the insulation in a broken or frayed condition. Don't pull or bend wires unnecessarily, nor pry cable open to trace wiring.

(8) Don't remove more than one vacuum tube from a receiver at one time. Remember to return each tube to the socket from which it was removed, unless it is defective.

c. Inspection. When a receiver is brought in from the field for check or repair, remove the cover and make the following inspection.

(1) Examine for burnt insulation and resistances. Examine for wax leakage and any discoloration of apparatus and wire. Notice any odor caused by overheated apparatus.

Note: These symptoms may have been caused by a trouble previously repaired and serve only as a guide. In general, confine examination to

parts readily visible with the cover removed. Usually more harm than good will be caused by the removal of the front panel, the FL or LCU can covers, and other enclosed parts. Trouble in these parts should be localized by signal tracing and voltage and resistance measurements.

(2) Inspect for broken connections to tube sockets, plugs, and other apparatus as well as for defective soldered connections. Examine for bare wires touching the chassis or other wires.

(3) Be sure that the labels on the tubes in the various sockets correspond to the correct tube numbers given in the technical manual for these positions. Replace any tubes which have the wrong numbers. Inspect for loose tube sockets.

(4) Inspect the active and spare fuses. Check carefully for short circuits whenever a receiver with a blown fuse is encountered.

(5) Inspect the selector mechanism for loose or bent parts. Be sure that the dial turns smoothly and that the push buttons operate satisfactorily.

(6) Inspect the power plug and replace or repair it if there are any bent or broken prongs.

(7) Inspect for loose or missing screws, especially those which fasten the tube sockets in place.

d. Power Supply Test. This test assumes that a voltmeter of at least 1000-ohms-per-volt with a range of at least 250 volts, and an ohmmeter, are available.

Throw all switches to OFF, or downward. Remove the cover from the receiver for the following procedure.

(1) The dynamotor marking must agree with the battery voltage available.

(2) Remove the dynamotor and examine it for loose or badly worn brushes and worn or dirty commutators. Test the continuity of the dynamotor plug. Clean and replace the dynamotor in the set.

(3) Connect the appropriate battery to the

receiver, using Mounting FT-237-(*) or Cord CD-786.

(4) Throw the SPEAKER switch to ON.

(5) Place the voltmeter across C25 (the positive side should go to the terminal to which the wire with the red tracer is attached). Turn the power switch to ON. Note that the meter rises immediately to approximately 200 volts when the switch is turned on. If it does not, turn the set off quickly and check C25 and C16 for a possible short circuit. Also, check the voltage divider, the dynamotor, and the associated equipment. A low reading of the voltmeter may indicate a faulty dynamotor or a short circuit in the system.

(6) If the dynamotor fails to start or if the fuse blows, turn the set off, and inspect the dynamotor and the associated equipment, as well as the fuse, plug PG2, the filament wiring, etc.

(7) Assuming that the dynamotor starts correctly and that the voltage is satisfactory, inspect the inside of the receiver with the dynamotor running. See that no sparks occur and that nothing smokes. Stop the dynamotor immediately and repair the fault if trouble is indicated.

(8) After the dynamotor has been running for a few moments, feel the tubes cautiously to see if they are all warm. No other tube should be as hot as V8, which is a VT-107-A (6V6-GT) tube. No tube should remain cold. If a tube remains cold after the others have warmed up, examine the wiring associated with the tube socket in question and examine the socket contacts. If there is no wiring trouble and the tube does not warm up, test it (or replace it if no vacuum-tube test set is available).

e. Vacuum Tube Testing Procedure. As the space around a vacuum tube is often small it is desirable either to use a tube extractor or to rock the tube with the fingers at the top while pushing it up gently from the bottom. To test a vacuum tube, use a test set if available. If not, try the tube in a receiver which is operating satisfactorily. If another receiver is not available, try replacing the tube by another one.

f. Operational Test. To make an operational test, you will need a headset and a weak signal between 27 and 39 megacycles. A signal generator, or a transmitter with its RECEIVER TUNE-OPERATE switch at RECEIVER TUNE, is a good signal source. The transmitter requires no metallic connection with the receiver. A second receiver with a lead to bring the radio frequency to the A (antenna) post of the receiver under test is satisfactory. See Paragraph 39g(6) (c).

Serious distortion and abnormally low output are trouble indications. Compare with a good receiver for output, if the condition of the trouble receiver permits. Irregularities of operation help to localize the trouble. Operating personnel may supply useful *supplementary* data.

(1) Turn the trouble receiver to ON and allow it sufficient time to warm up. All other switches should be at OFF (down).

(2) *CALL SIGNAL Lamp.* With the SQUELCH switch at OFF, the CALL SIGNAL lamp should be lighted.

(3) *Noise from Loudspeaker.* Turn the SPEAKER switch to ON, and with the VOLUME control turned to the extreme right, listen for a rushing noise from the loudspeaker.

(4) *VOLUME Control.* The speaker output should vary smoothly from maximum until the noise has vanished at the extreme left position of the control.

(5) *Headset Sidetone.* With the OUTPUT TO PHONES switch at OFF, plug the headset into one of the PHONES jacks. There should be no sound in the headset.

(6) *Noise in Headset.* With the VOLUME control adjusted for normal output from the speaker, turn the OUTPUT TO PHONES switch to ON. There should be a rushing noise in the headset.

(7) *Noise in Headset, Second Jack.* Repeat step (6) for the second PHONES jack.

(8) *Headset Volume.* Turn the SPEAKER switch on and off. The headset volume should remain constant if R30 is intact.

(9) Turn on a source of radio-frequency signal and wait for it to warm up.

(10) *Beat-Note Indication.* Now place the TUNE-OPERATE switch at TUNE. Roughly check the tuning of the receiver, both manual and push-button, against the radio-frequency test signal, using the beat note produced by the intermediate-frequency oscillator as a tuning indication. The dial should turn freely.

(11) *Beat-Note Indication, with Squelch.* With the SQUELCH switch at ON and the SENSITIVITY control adjusted for maximum sensitivity (full right rotation), repeat the beat-note test at one frequency.

(12) *Squelch Operation.* With conditions as in (11), the CALL SIGNAL lamp should light when the signal is tuned in. If it does not go out when the signal is tuned out, turn the SENSITIVITY control to the left to reduce the sensitivity until it does. The noise from the loudspeaker should cease whenever the CALL SIGNAL lamp is extinguished. When the signal is tuned in again the lamp should light.

(13) *Sensitivity Control.* Reduce the signal, with conditions as in (12), just short of the frequency where the CALL SIGNAL lamp would go out. Turn the SENSITIVITY control to the left and the lamp should go out.

(14) *Intermittents.* Test the receiver for intermittents by jarring it while listening to a beat note.

(15) *Tests Involving Transmitter and Receiver.* If the tests are being made in a mounting with a transmitter as a source of radio frequency, the following checks may be made quickly:

(a) *Disabling Action.*—Turn the transmitter RECEIVER TUNE-OPERATE switch to OPERATE. Pressing the microphone button should cut off the rushing noise in the receiver.

(b) *Sidetone.*—Plug into either PHONE jack and set the SIDETONE control on the right end of the transmitter (Fig. 14) to give sufficient headset volume. Sidetone should be heard when someone is speaking into the microphone.

g. Signal Tracing.

(1) *General.* Signal tracing tests require one of the following signal sources, listed in order of preference:

A signal generator.

A good receiver. (See (6) of this paragraph for instructions.)

A good transmitter (provides audio and radio frequencies only). (See (7) of this paragraph for instructions.)

Caution: When connecting or disconnecting these sources, turn the receiver off each time to avoid shock or equipment damage.

You will also need a voltmeter (not less than 1000-ohms-per-volt), an ohmmeter, and a headset. If no vacuum-tube test set is available, check the tubes in a good receiver, or substitute new tubes. (See Paragraph 39e.) This recommended procedure begins at the output and works back. For the location of parts, see Figs. 43, 45, 46, 51, and 72. An output meter plugged into one of the PHONES jacks, as described in Paragraph 33c(3), or an alignment meter bridged across L1 as described in Paragraph 33e(1), helps greatly in judging the performance of the receiver. If a signal generator having a 1.0-volt output at 2.65 megacycles is used, test the discriminator circuits, as described in step (3)(i), as soon as step (3)(b) is completed. In this event, apply the signal generator output to the grid of the limiter (terminal 4 of V6). In all other cases, make this test in the following order:

(a) At the beginning of the test, turn all switches to OFF (downward), and release all push buttons.

(b) *Don't remove the shield can of a tuned unit until the trouble has been traced to that particular unit. Don't remove the front panel of the receiver more often than necessary. Don't damage the wiring by pushing it back and forth during inspection. Do as little damage to the receiver as possible. Take it easy.*

(c) Use a dynamotor known to be in good condition, and of correct voltage, and place it in the set before the test.

(d) Except as otherwise noted, ground

one side of the signal generator and connect the other side to the receiver being tested.

(e) Note the volume, and listen for serious distortion from the loudspeaker at the various points in the signal tracing procedure. Experience helps. If possible, compare with a receiver known to be in good condition.

(f) Check the wiring and soldering in each stage as you proceed.

(g) Misalignment of one or more stages of the receiver will cause reduced output. Misalignment of the radio-frequency oscillator may, however, prevent *any* output.

(h) In this outline, "no signal" or "no beat note" means either no signal from the loudspeaker, a signal that is weaker than it should be, or a seriously distorted signal.

(i) When trouble is localized in a given stage, first test the tube if such a test is indicated in the procedure, then the voltage, and finally the resistance (Paragraph 39b(4)), at the tube socket of that stage.

(j) Trouble in a circuit or stage may not show in voltage and resistance measurements at the tube socket. Hints included in this section are merely a guide and should suggest other procedures, such as voltage and resistance measurements on individual parts.

(k) Remove only *one tube* at a time when testing. Check the number of the tube, test it, and return it to its proper socket before another tube is removed.

(l) If the receiver appears to be good, test the control circuits of the associated transmitter for short or open circuits. Check the wiring in Mounting FT-237-(*), as well as the remote circuit wiring.

(m) It frequently helps to connect (with a clip lead) terminal 5 of V3 to the negative side of C25 (to which blue-tracer leads are attached) when performing the audio- and intermediate-frequency tests outlined in Paragraphs 39g(2) and (3). This stops the radio-frequency oscillator and reduces interference. *Be sure to remove this clip lead before proceeding with the radio-frequency tests.*

(n) Each step assumes you have satis-

factorily completed all previous steps. Isolate and clear any trouble located before you proceed with the next step.

(o) When you have found all sources of trouble, follow the procedure for routine check of the receiver as described in Paragraph 30.

(2) *A-f Tests.* For reference to audio-frequency-test signal sources, see Paragraph 39g(1).

(a) Secondary of T1 (Speaker Circuit).—Throw the SPEAKER switch to ON and connect an audio signal through a series capacitor to the blue-brown tracer (fifth terminal counting from the front panel) on the output transformer T1. Listen for noise output in the speaker. Notice that it is not necessary to remove the front panel in order to gain access to the terminals of transformer T1.

The volume of noise will be *very low*.

If no output is heard, check the circuit elements such as the SPEAKER switch D3, the output transformer, the loudspeaker, etc.

Note: In replacing the front panel (if it has been removed) be sure that the wires are all pushed down beside the potentiometers P1 and P2 and preferably tied in place.

(b) Secondary of T1 (Phones Circuit).—Throw the OUTPUT TO PHONES switch to ON and connect the signal to the blue-green tracer on the output transformer T1 (third terminal counting from the front panel). Try the headset in both PHONES jacks. Noise should be heard when the headset is plugged into either jack. If no signal is heard, remove the front panel and test (by resistance measurements if possible) such items as resistors R22, R23, and R33, switch D2, the jacks, and terminals 12 and 14 of PG3 and J3. Jacks and headsets may be at fault, or a permanent ground may exist on the receiver disabling lead.

(c) Primary Circuit of T1.—Place the audio signal on the blue-yellow tracer (second terminal counting from the front panel) on the output transformer T1 and listen for the signal from the speaker or headset. If no signal is present, C33 may be shorted or terminals 16 and 17 of plug PG3 may not be making good contact.

(d) Terminal 5 of V8 (Grid of Second Audio Amplifier).—Turn the receiver on. Put the signal on terminal 5 of V8. Listen for output in the speaker. If there is no output, test the tube and the voltages at the socket terminals (see Figs. 57 and 58). C21, R19, or R18 may be faulty. Check continuity to terminals 5, 6, and 10 of PG3 or J3.

(e) Terminal 2 of V10 (Plate of First Audio Amplifier).—Introduce the signal at terminal 2 of V10, and listen for a signal from the loudspeaker. If there is no signal, R18, C19, or C21 may be at fault. Check terminals 5, 6, and 10 of PG3 or J3 for continuity.

(f) Terminal 1 of V10 (Grid of First Audio Amplifier).—Put the signal on terminal 1 of V10. Reduce the signal input. If there is no signal from the loudspeaker, test the tube. Circuit elements such as C11, C12, C13, C26, or R10 may be faulty. Note that when the SQUELCH switch is at OFF it should connect ground to R12—the side away from the tube.

(g) Terminal 5 of V10 (Plate of the I-f Oscillator).—Place the signal on terminal 5 of V10. Throw the TUNE-OPERATE switch to OPERATE. If there is no signal from the loudspeaker, R6, C26, C10, or D5 may be faulty.

(h) Junction of C11 and R10.—Put the signal at the junction of C11 and R10. If the signal is not heard from the speaker, R10 or C11 may be faulty.

(i) Terminal 4 of V7 (Output of the Discriminator).—Place the signal across the output resistance (R81 in series with R83) of the discriminator (terminal 4 of V7). If there is no signal in the loudspeaker, check circuit elements such as V7, C81, C82, R81, R82, R83, or R84.

(3) *I-f Tests.* For reference to intermediate-frequency-test signal sources, see Paragraph 39g (1).

(a) Terminal 8 of V6 (Plate of the Limiter).—With the intermediate-frequency signal applied through a series capacitor to the plate of the limiter (terminal 8 of V6), place the SQUELCH switch at OFF and the TUNE-OPERATE switch at TUNE and listen for a beat note from the loudspeaker. If this beat note is not heard,

note the setting and then vary the slug adjustment in LCU4 to obtain a beat note. If the beat note cannot be obtained, such circuit elements as C10, LCU4, FL4, or D5 may be faulty. Retune the slug in LCU4 for a beat note with the intermediate-frequency source after the trouble has been cleared.

(b) Terminal 4 of V6 (Grid of the Limiter).—Put the signal on terminal 4 of V6. If there is no beat note from the speaker, with the TUNE-OPERATE switch at TUNE, test V6 and other circuit elements. Voltage and resistance measurements at the tube socket terminals may be useful. (See Figs. 57 and 58.)

(c) Terminal 8 of V5 (Plate of the Second I-f Amplifier).—With the signal on terminal 8 of V5 repeat the procedure given for the preceding stage. If there is no signal, FL3A may be misaligned or faulty. If the alignment is not at fault, test such elements as V5, R13, C14, C15 or C7. If the alignment has been altered, re-align FL3A after the trouble has been corrected.

(d) Terminal 4 of V5 (Grid of the Second I-f Amplifier).—Place the signal on terminal 4 of V5. Repeat the procedure which was followed on the limiter stage. If the test of the tube is satisfactory, there may be trouble in circuit elements such as FL2A, C7, or R8.

(e) Terminal 8 of V4 (Plate of the First I-f Amplifier).—Feed the signal to terminal 8 of V4. If no beat note is obtained from the speaker, test the tube. FL2A may be misaligned or may be faulty.

(f) Terminal 4 of V4 (Grid of the First I-f Amplifier).—Introduce a signal on terminal 4 of V4. If no beat note is obtained and the tube is satisfactory, the trouble may be in FL1A, C6, or associated circuit elements.

(g) Terminal 8 of V2 (Plate of the Modulator).—With the signal on terminal 8 of V2, listen for a beat note from the loudspeaker. If none is obtained, test the tube and make voltage and resistance measurements. (See Figs. 57 and 58.) FL1A may be misaligned or faulty. Check the associated circuit elements.

(h) Terminal 4 of V2 (Grid of the Modulator).—Place the signal on terminal 4 of V2.

If a beat note is not obtained, test the tube. The trouble may be in LCU2A. Check for a short circuit of C1.5 or C1.6.

(i) Terminal 4 of V2 (Discriminator Test).—With the intermediate-frequency signal still on the grid of the modulator (terminal 4 of V2), measure the voltage across the series combination of R81 and R83 (between terminals 4 and 8 of V7, or between 3 and 7 of FL4). Turn off the intermediate-frequency oscillator by setting the TUNE-OPERATE switch at OPERATE. Align the secondary of FL4 to obtain a zero reading on the voltmeter. As the alignment is varied either way from this point, the reading of the voltmeter should change polarity. In order to test the primary of FL4, connect the meter between terminals 3 and 8 of FL4. Adjust the primary slug of FL4 for maximum reading on the voltmeter. This is not an alignment but merely a check on the alignment capability of this circuit. Leave the circuit in approximate alignment after clearing any trouble that may have been present in FL4 or associated circuits.

(4) *R-f Tests.* For reference to radio-frequency-test signal sources, see Paragraph 39g (1).

(a) Terminal 4 of V2 (Grid of the Modulator).—Apply a radio-frequency signal through a capacitor to the grid of the modulator (terminal 4 of V2). Set the TUNE-OPERATE switch to TUNE. Manually set the dial of the trouble receiver to approximately the frequency of the radio-frequency source and tune for a beat note. If it is impossible to obtain a beat note, either the source of radio frequency is not providing voltage on the grid of V2 or the radio-frequency oscillator of the trouble receiver is not functioning. In the latter case check V3, LCU3A, R4, R5, C5, and associated circuit elements. C1.7 and C1.8 may be shorted. Make resistance and voltage measurements at the tube socket terminals. (See Figs. 57 and 58.) In order to isolate the trouble in the oscillator stage, put the radio-frequency signal on the suppressor grid of the modulator (terminal 3 of V2). If the characteristic no-signal rushing noise is heard from the loudspeaker with the test signal but is

not heard when the test signal is absent, then the oscillator stage is faulty. However, if the oscillator stage is operating but not properly aligned, the rushing noise may be present, but a weak beat note may appear more than one channel away from the proper setting. A realignment of the oscillator is indicated.

Caution: Any attempt to vary the adjustment of the slug in LCU3A will result in a change in the tracking of the oscillator stage. This stage probably will then require careful alignment. This procedure is described in Paragraphs 34b(5) and 37e. No adjustment of LCU3A and C1.7 should be attempted until the method is fully understood.

(b) Terminal 8 of V1 (Plate of the R-f Amplifier).—Place the signal on terminal 8 of V1. If no beat note is heard in the speaker, test V1. It may be that LCU2A, C1.3, or C1.4 are shorted. Make voltage and resistance measurements.

(c) Terminal 4 of V1 (Grid of the R-f Amplifier).—Place the signal on terminal 4 of V1 and listen for the beat note. If no beat note can be obtained and the tube is not at fault, check LCU1A, C1.1, and C1.2 for short circuits. LCU2A may be misaligned.

(d) Antenna Post.—Put the signal on the A (antenna) post. If there is no beat note, LCU1A may be misaligned or faulty. Test the antenna connections to LCU1A.

(e) Squelch Circuit and Sensitivity Control.—Check these functions as described in Paragraphs *f(12)* and *f(13)* preceding. If operation of the squelch circuit and sensitivity control is not normal, test V9. Circuit elements such as R15, R16, R17, C17, C18, C20.2, or C12 may be faulty.

Note: The voltage divider circuits bear an important relation to proper squelch action. See Figs. 57 and 58.

(f) Tuning.—When all troubles have been removed, the tuning for all channels should be checked. If an LCU or an FL unit has been repaired or replaced or if its adjustment has been changed, that unit should be realigned. If several

units have been changed or there is any question of alignment, the whole receiver should be realigned.

(5) *Short Cuts.* Signal tracing procedure may be simplified by determining at the outset, whether the trouble is in the audio-, intermediate-, or radio-frequency circuits. This may be determined in the following order:

(a) *A-f Circuits.*—Put an audio-frequency signal on the output of the discriminator (terminal 4 of V7). If output from the speaker is missing or weak, the trouble is probably located in the audio-frequency circuit.

Caution: Unless you are familiar with these sets, you may fail to recognize a loss of amplification in the set in these tests. It's a good idea to make a comparison with a receiver known to be in good condition.

(b) *I-f Circuits.*—Put an intermediate-frequency signal on the grid of the modulator (terminal 4 of V2). When the TUNE-OPERATE switch is at TUNE, a beat note should be heard. If step (a) gave a beat note but none is heard now, the trouble is probably in the intermediate-frequency part of the circuit.

(c) *R-f Circuits.*—Place a radio-frequency signal on the A (antenna) post. Tune the receiver to the frequency of the test signal. Throw the SQUELCH switch to ON. The squelch circuit should operate satisfactorily with the SENSITIVITY control near its minimum or extreme left position. Throw the SQUELCH switch to OFF; a beat note should be heard from the speaker. The tuning dial setting should agree approximately with the test signal frequency. Test the squelch and sensitivity control operation as described in Paragraphs *f(12)* and *f(13)* preceding.

(6) *Use of a Second Receiver as a Signal Generator.* If you have no signal generator, it will help a lot to have a second receiver handy. Keep it in good operating condition at all times to use as a source of test signals. The audio-, intermediate-, and radio-frequency signals may be obtained from the following points in the good receiver, in the following manner:

(a) *Audio Frequency.*—Audio-frequency signals may be obtained from one of the PHONES jacks of the good receiver. The VOLUME control of this receiver may be adjusted to give a satisfactory level of no-signal noise for use in testing the audio stages of the trouble receiver. If the signal strength is too great, the audio stages of the trouble receiver may be overloaded, thereby giving deceptive results. Connect the *tip* of a plug to a capacitor of 0.001 microfarad or greater capacitance. Insert the plug into one of the PHONES jacks to obtain an audio-frequency source. Connect the chassis of the two receivers together to complete the circuit. Throw the OUTPUT TO PHONES switch to ON.

(b) *Intermediate Frequency.*—You may obtain the intermediate frequencies from the second receiver, with the TUNE-OPERATE switch at TUNE, at terminal 7 of FL4. You can pick up a somewhat higher output on terminal 2 of FL4; use the former (lower level) point for all cases except where the circuits are badly misaligned. In all cases make the connection through a capacitor, preferably 0.001 microfarad or larger, located close to the source of test tone. If you have no capacitor, twist two *insulated* wires for about 18 inches, making sure that there is *no metallic connection between the wires*. These two wires (at the far end) form the two ends of the lead which carries the test frequencies. In order to prevent unwanted pickup and singing, combine this lead (in a twisted pair) with the ground wire which forms the circuit return. Mark each wire so it may be identified, equip each end of the pair with clips, and run it directly from the signal source to the point of use, preferably under the bottom of the good receiver (if it is at the left side). Leave the untwisted part as short as possible. This twisted pair for pickup and test frequency will then consist of:

(1) An insulated wire about 3-feet long used for connecting the chassis of the trouble receiver to the chassis of the source.

(2) Another insulated wire about 4-feet long cut in the middle and with the two

CAUTION: DANGEROUS VOLTAGES ARE EXPOSED

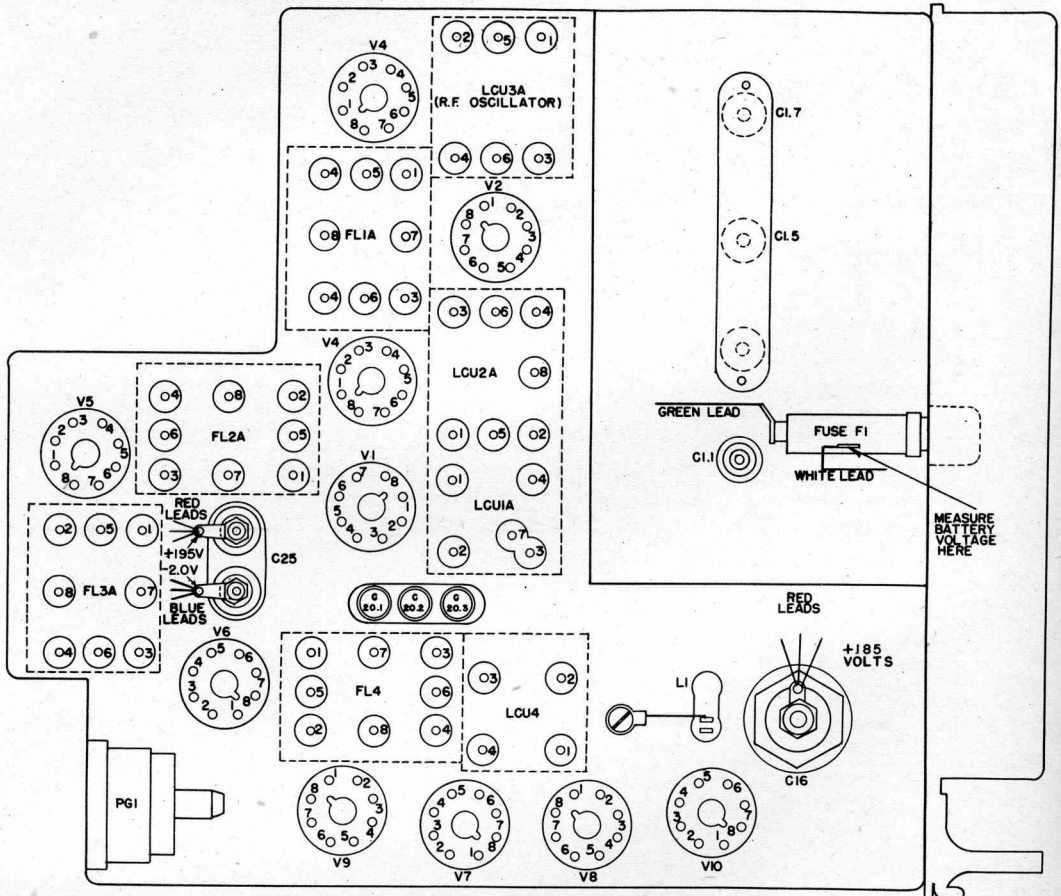

LEFT SIDE VIEW OF RECEIVER, COVER REMOVED, SHOWING DC POTENTIALS BETWEEN THE DESIGNATED TERMINALS AND THE RECEIVER CHASSIS ON METER OF 1,000 OHMS PER VOLT.

NOTES:

1. ALL VOLTAGES SHOULD BE MEASURED BETWEEN THE DESIGNATED TERMINAL AND THE RECEIVER CHASSIS.
2. ALL SWITCHES EXCEPT THE TUNE-OPERATE AND THE ON-OFF SHOULD BE IN THE DOWNWARD POSITION.
3. VOLTAGES GIVEN ARE AVERAGE READINGS. A RECEIVER WHICH IS OPERATED SATISFACTORILY NEED NOT BE SERVICED JUST BECAUSE CERTAIN READINGS DIFFER FROM THOSE GIVEN AS DIFFERENCES IN MANUFACTURED EQUIPMENT CAUSE VARIATION IN VOLTAGES.
4. FIGURES GIVEN ARE BASED ON 12 OR 24 VOLTS FROM THE BATTERY. FOR OTHER BATTERY VOLTAGES THE READINGS GIVEN SHOULD BE ADJUSTED IN PROPORTION.
5. ACCURACY REQUIRES THAT ON MEASUREMENTS WITH A METER OF 1000 OHMS PER VOLT, FULL-SCALE READING MUST BE HIGHER THAN THE EXPECTED VOLTAGE.
6. VACUUM TUBE VOLTMETER MEASUREMENTS ARE BASED ON A VOLT-OHMMEETER 1-107 OR EQUIVALENT.
7. \diamond MEANS NOT TO EXCEED 0.5 VOLTS ON METER OF 1,000 OHMS PER VOLT.

Fig. 57. Radio Receiver BC-6

STAGE-BY-STAGE GAIN DATA FOR TROUBLE LOCATION

INPUT CONNECTION *	TEST FREQUENCY	INPUT REQUIRED TO OPERATE	SQUELCH	INPUT REQUIRED FOR EQUIV. CATHODE METER READINGS**	OUTPUT METER READING ***
TERM. 4 OF V6 AND CHASSIS	2.65 MC			1 VOLT	16 VOLTS (APPROX.) 400 GFS.
" " " " " "	"	2 VOLTS (MAX.)			
TERM. 4 " V5 " " "	"	0.1 VOLT (APPROX.)		0.05 VOLT (APPROX.)	16 VOLTS (APPROX.) 400 GFS.
" " " " " "	"			1500 MICROVOLTS (APPROX.)	16 VOLTS (APPROX.) 400 GFS.
" " " " " "	"	3000 JUV (APPROX.)			
" " " " " "	"			50 MICROVOLTS (MAX.)	16 VOLTS (APPROX.) 400 GFS.
" " " " " "	"	100 JUV (MAX.)			
" " " " " "	39 MC			300 MICROVOLTS (APPROX.)	16 VOLTS (APPROX.) 400 GFS.
" " " " " "	"	600 JUV (APPROX.)			
TERM. 8 " V1 " " "	"			100 MICROVOLTS (APPROX.)	16 VOLTS (APPROX.) 400 GFS.
" " " " " "	"	200 JUV (APPROX.)			
TERM. 4 " V1 " " "	"			1.5 MICROVOLTS (APPROX.)	16 VOLTS (APPROX.) 400 GFS.
" " " " " "	"	3 JUV (APPROX.)			
ANT. AND GND. TERMINALS	27 MC				
" " " " " "	39 MC		1 MICROVOLT INPUT		11 VOLTS (APPROX.) 150 GFS.
" " " " " "	"		" " "		20 " " 400 GFS.
" " " " " "	"		" " "		20 " " 1000
" " " " " "	"		" " "		11 " " 2500
" " " " " "	"		" " "		4 " " 5000
TERM 5 OF V8 AND CHASSIS	1000 GFS. Δ			1 VOLT "	2 " " 1000
" " " " " "	"			" " "	18 " " 1000

- * THE SIGNAL GENERATOR CONNECTION SHALL ALWAYS BE MADE THROUGH A .006 MF SERIES CONDENSER.
- ** APPLY 1 VOLT OF 2.65 MEGACYCLES BETWEEN TERMINAL 4 OF V6 AND CHASSIS TO OBTAIN THE EQUIVALENT "CATHODE" METER (FIG. 65) READING. BETWEEN 4 AND 8 MICROAMPERES SHOULD BE OBTAINED.
- *** SQUELCH SWITCH OFF AND VOLUME CONTROL IN MAXIMUM CLOCKWISE POSITION. A FREQUENCY MODULATED SIGNAL GENERATOR (±15 KC DEVIATION) IS REQUIRED FOR OUTPUT MEASUREMENTS INVOLVING RF AND I.F. INPUTS. SPEAKER SWITCH SHOULD BE IN OFF POSITION WHEN MEASUREMENTS ARE MADE.
- Δ THIS MEASUREMENT MAY BE MADE IF AN AUDIO FREQUENCY SOURCE IS AVAILABLE.

MEASURE BATTERY VOLTAGE HERE

VOLTAGES AT TERMINALS OF FL AND LCU UNITS					
FL UNITS			LCU UNITS		
TERMINAL	VOLTAGE		TERMINAL	VOLTAGE	
	1000 OHM PER VOLT METER (NOTE 5 & 7)	VACUUM TUBE VOLT METER (NOTE 6)		1000 OHM PER VOLT METER (NOTE 5 & 7)	VACUUM TUBE VOLT METER (NOTE 6)
FL1A			LCU1A		
1	70	75	1	0	-2
2	70	75	2	0	0
3	0	0	3	0	0
4	0	0	4	0	0
5	185	185			
6	0	-2	7	0	-2
7	0	-2			
8	0	-2			
FL2A			LCU2A		
1	175	180	1	175	180
2	175	180	2	175	180
3	0	0	3	185	185
4	0	0	4	0	0
5	185	185	5	0	0
6	0	-2	6	0	0
7	-	-2	8	175	180
8	-2	-2			
FL3A			LCU3A		
1	55	60	1	0	0
2	55	60	2	135	145
3	0	0	3	0	0
4	0	0	4	135	145
5	60	60	5	2	-10
6	0	-2	6	0	-2
7	-	-2			
8	-2	-2			
FL4			LCU4		
1	25	25	1	185	185
2	55	60	2	0	0
3	5.5	25	3	135	160
4	5	20	4	0	-0.5
5	55	60			
6	5	25			
7	5	25			
8	5	25			

VOLTAGES AT VACUUM TUBE SOCKET TERMINALS										
1000 OHM PER VOLT VOLT METER MEASUREMENTS (SEE NOTES 5 & 7)										
12 VOLT BATTERY										
TERM. NOS.	V1	V2	V3	V4	V5	V6	V7	V8	V9	V10
1	0	0	0	0	0	0.5	5.5	0	0	0
2	0	12	0	12	12	6	12	6	0	7.0
3	0	0	135	0	0	0.5	5	185	15	0.5
4	0	0	0	0	0	0	5.5	170	0	0
5	0	12	0	0	0	0.5	5	0	0	135
6	145	40	0	115	90	55	0	0	5	0
7	6	6	6	0	12	6	0	0	5	6
8	175	70	0	175	55	55	5.5	6	0	12
24 VOLT BATTERY										
1	0	0	0	0	0	0	0	0	0	0
2	0	12	0	12	12	6	12	6	0	7.0
3	0	0	135	0	0	0.5	5	185	15	0.5
4	0	0	0	0	0	0	5.5	170	0	0
5	0	12	0	0	0	0.5	5	0	0	135
6	145	40	0	115	90	55	0	0	5	0
7	6	6	6	0	12	6	0	0	5	6
8	175	70	175	175	55	55	5.5	6	24	12
VOLTAGES AT VACUUM TUBE SOCKET TERMINALS										
VACUUM TUBE VOLT METER MEASUREMENTS (SEE NOTE 6)										
12 VOLT BATTERY										
TERM. NOS.	V1	V2	V3	V4	V5	V6	V7	V8	V9	V10
1	0	0	0	0	0	0	0	0	15	0
2	0	12	0	12	12	6	12	6	0	7.5
3	0	-2	145	0	0	0.5	20	190	15	1
4	-2	0	0	-2	-2	-2	25	180	-2	-1.5
5	0	1.3	-10	0	0	0.5	20	-2	-2	160
6	155	55	0	120	90	60	0	0	20	0
7	6	6	6	0	12	6	0	0	20	6
8	180	75	0	180	60	60	25	6	0	12
24 VOLT BATTERY										
1	0	0	0	0	0	0	0	0	15	0
2	0	12	0	12	12	18	12	18	0	7.5
3	0	-2	145	0	0	0.5	20	190	15	1
4	-2	0	0	-2	-2	-2	25	180	-2	-1.5
5	0	1.3	-10	0	0	0.5	20	-2	-2	160
6	155	55	0	120	90	60	0	0	20	0
7	6	6	6	0	12	6	0	0	24	18
8	180	75	0	180	60	60	25	6	24	12

RESISTANCE AT TERMINALS OF PG 2 (OHMS)	
TERMINAL	RESISTANCE VALUES
1	0
2	6
3,4,5,6	OPEN
7	50
8	OPEN
9	6
10,11	OPEN
12	5.4
13	18,000
14	OPEN
15	9
16,17,18	OPEN

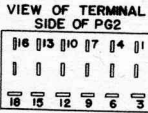

RESISTANCE AT TERMINALS OF PG1 (OHMS)	
TERMINAL	RESISTANCE VALUES
1	OPEN
2	0
A1	OPEN
3	800
4,5	OPEN
6	3,600
7	250
8,9	OPEN
10	155,000
18	400,000
19,20,21	OPEN
22	50
23	OPEN
24	250,000
25	OPEN

VIEW OF PRONG SIDE OF PG1

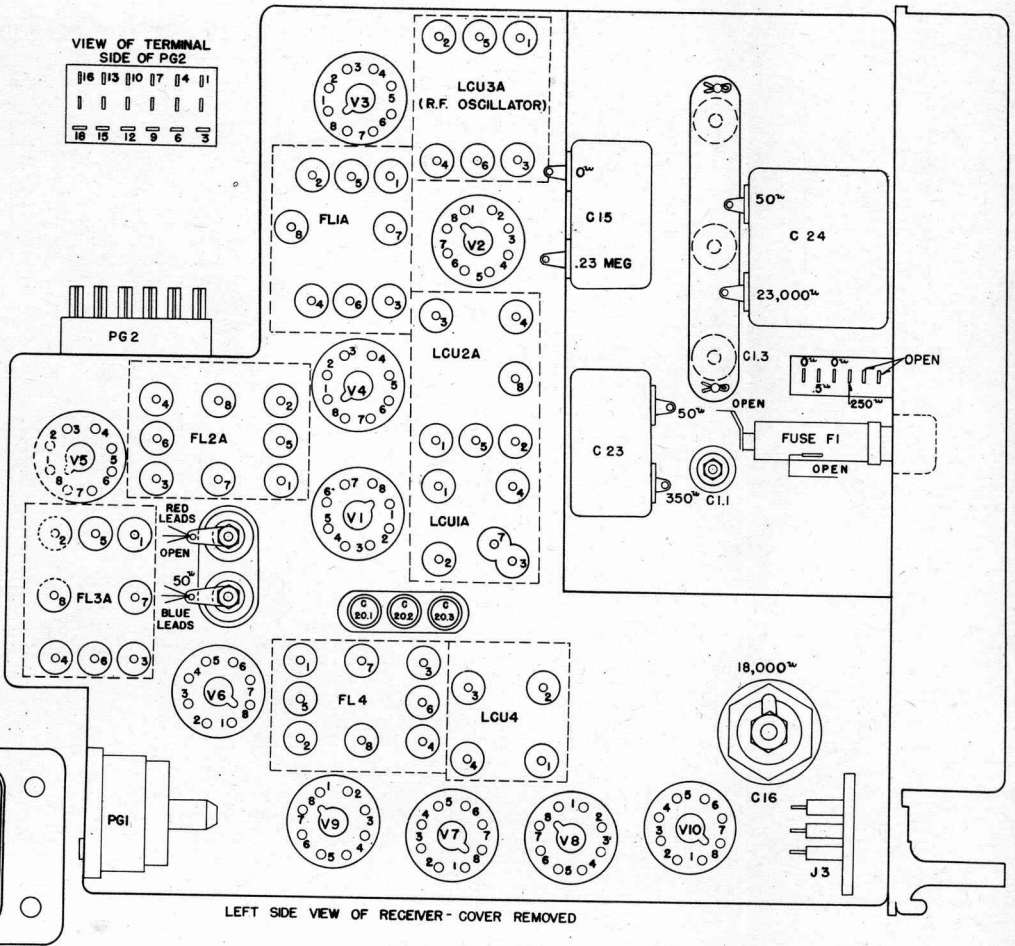
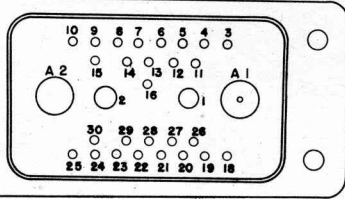

LEFT SIDE VIEW OF RECEIVER - COVER REMOVED

NOTES:

1. ALL RESISTANCE VALUES SHOWN ARE MEASURED BETWEEN THE RECEIVER CHASSIS AND DESIGNATED TERMINAL POINT.
2. A VARIATION OF $\pm 20\%$ FROM THE INDICATED VALUES SHOULD NOT BE REGARDED AS AN INDICATION OF A DEFECTIVE RECEIVER.
3. CERTAIN DISCREPANCIES MAY BE OBSERVED BETWEEN THE SCHEMATIC DRAWING CONTAINED IN THESE INSTRUCTIONS AND THE CIRCUIT LABEL APPEARING ON THE RECEIVER. THESE DISCREPANCIES ARE DUE TO CHANGES MADE IN MANUFACTURE. IN SUCH CASES THE CIRCUIT LABEL APPLIES. NATURALLY, SUCH DISCREPANCIES MAY BE AFFECT THE RESISTANCE VALUES INDICATED.
4. THE DYNAMOTOR MUST BE REMOVED BEFORE MAKING ANY RESISTANCE MEASUREMENTS.
5. PLACE ALL SWITCHES IN THE "OFF" OR DOWNWARD POSITION EXCEPT THE TUNE-OPERATE AND THE OUTPUT TO PHONES SWITCHES WHICH SHOULD POINT UP.
6. TURN THE VOLUME AND SENSITIVITY CONTROLS TO THEIR MAXIMUM CLOCKWISE ROTATION.
7. TO CHECK THE VOLUME CONTROL, CONNECT THE OHM-METER TEST LEAD TO TERMINAL 5 OF J3. WITH THE VOLUME CONTROL AT MAXIMUM THE MEASURED RESISTANCE SHOULD BE APPROX. 100,000 OHMS AND SHOULD DECREASE TO 50 OHMS AS THE VOLUME CONTROL IS TURNED TO ITS EXTREME COUNTERCLOCKWISE POSITION.
8. TO CHECK THE SENSITIVITY CONTROL, MEASURE THE RESISTANCE FROM THE TERMINAL OF C25 TO WHICH THE BLUE LEADS ARE ATTACHED. THE RESISTANCE AT THIS POINT SHOULD VARY BETWEEN 50 AND 250 OHMS AS THE SENSITIVITY CONTROL IS ROTATED. WHEN THIS CHECK IS MADE THE SQUELCH SWITCH MUST BE IN THE "ON" POSITION. ALL OTHER CHECKS ARE MADE WITH THIS SWITCH OFF.

Fig. 58. Radio Receiver BC-683-A: F

RESISTANCES AT VACUUM TUBE SOCKET TERMINALS (OHMS)										
TERMINAL	V 1	V 2	V 3	V 4	V 5	V 6	V 7	V 8	V 9	V 10
1	0	0	0	0	0	0	0	0	2 MEG	1.1 MEG
2	0	4**	0	9**	9**	5**	5**	5**	0.25 MEG	.1 MEG
3	0	100,000	25,000	0	0	800	165,000	OPEN	2,500	2,000
4	500,000	0	OPEN	500,000	110,000	260,000	155,000	25,000	250,000	100,000
5	0	500	50,000	0	0	800	165,000	100,000	250,000	40,000
6	40,000	270,000	OPEN	50,000	90,000	10,000	OPEN	OPEN	165,000	0
7	2.5**	2.5**	4**	0	5**	4**	5**	5**	5**	4**
8	21,000	70,000	0	21,000	9,000	10,000	155,000	350	5**	5**

** TUBE FILAMENT RESISTANCE SUBJECT TO LARGE VARIATION WITH HEAT

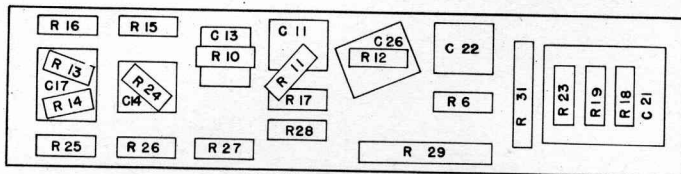

RESISTANCE STRIP

RESISTANCES AT RESISTANCE STRIP		
UNIT	LEFT SIDE (OR BOTTOM)	RIGHT SIDE (OR TOP)
R 16	2 MEG	1 MEG
R 13	0.25 MEG	0.25 MEG
C 17	0	1 MEG
R 14	50	0.25 MEG
R 25	0	2,500
R 15	1 MEG	165,000
R 24	50	0
C 14	0.25 MEG	0
R 26	2,500	3,700
R 10	0.155 MEG	0.4 MEG
C 13	0	12 MEG
R 27	3,700	6,000
C 11	0.4 MEG	1.1 MEG
R 11	0.25 MEG	1.1 MEG
R 17	0.25 MEG	0
R 28	6,000	8,700
C 26	1.1 MEG	150,000
R 12	0	2,000
R 29	8,700	17,000
C 22	OPEN	OPEN
R 6	150,000	40,000
R 31	17,000	20,000
R 23	23,000	20,000
R 19	1 MEG	20,000
R 18	1 MEG	1 MEG
C 21	0.1 MEG	1 MEG

VIEW OF TERMINAL SIDE OF J3

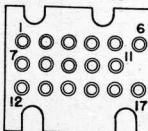

RESISTANCES AT FILTER TERMINALS		
FILTER	TERMINAL	RESISTANCE
LCU1A	1	0.26 MEG
	4	0
	3,2	OPEN
	7	0.5 MEG
LCU2A	1,2,3,8	20,000
	4,5,6	0
	1	0
LCU3A	2	25,000
	3	OPEN
	4	25,000
	5	50,000
	6	0.1 MEG
LCU4	1	18,000
	2	2.5
	3	40,000
	4	0.1 MEG
FL1A	1,2	70,000
	3,4	0.5 MEG
	5	20,000
FL2A	6	0.26 MEG
	1,2	20,000
	3	0
FL3A	4	3.5
	5	18,000
	6	110,000
	7	10,000
	8	50
	1,2	10,000
	3	0
	4	3.5
5	9,000	
FL4	6	260,000
	7	10,000
	8	50
	1	3,700
	2	10,000
	3,4,6,8	150,000
	7	155,000
	5	8,700

RESISTANCES AT TERMINALS OF J3 (OHMS)	
TERMINAL	RESISTANCE VALUES
1, 2	OPEN
3	20 000
4	1 MEG
5	80 000
6	50
7,8	OPEN
9	6,000
10	100,000
11	50
12	250
13	0
14	OPEN
15	18,000
16,17	OPEN

ends connected through a capacitor or wrapped together for about 18 inches where they overlap.

(c) Radio Frequency.—The radio frequency may be obtained from the good receiver at the suppressor grid of the modulator (terminal 3 of V2). For most alignment purposes, the stray pickup between two receivers placed about 2 feet apart is sufficient. For signal tracing, more pickup may be necessary. In this event, connection may be made by using a capacitor or two wires twisted together as described in (b). This frequency will be about 2.65 megacycles above the frequency indicated by the dial. Therefore, tune the receiver being tested to a frequency which is approximately 2.65 megacycles above that to which the good receiver is tuned.

(7) *Use of a Radio Transmitter BC-684-A as a Signal Generator.* If neither a signal generator nor a good receiver is available, you may use a transmitter in good operating order to provide a tone for tracing signals in the audio- or radio-frequency stages of a trouble receiver.

(a) Audio Frequency.—If the transmitter is in a mounting, an audio-frequency tone can be obtained from terminal 1 of the terminal strip TS401. You can see this terminal in the base of

the mounting when the door in the mounting at the left receiver position is opened.

Caution: Use a 0.001 to 1.0-microfarad capacitor in series with the lead, as one side of the audio source is grounded.

If the receiver is placed in a Mounting FT-237-(*) with this transmitter, throw the OUTPUT TO PHONES switch of the receiver to OFF. Turn the transmitter on. Audio frequencies will be available if the operator presses the microphone button of the transmitter and whistles or hums into the microphone. Use a throat microphone if you have it.

(b) Intermediate Frequency.—Since no source of 2.65 megacycles is available in the transmitter, no direct method of signal tracing in the intermediate-frequency section is available with the transmitter.

(c) Radio Frequency.—In general no direct connection between transmitter and receiver is necessary for picking up test radio frequencies for alignment work. In signal tracing where direct connection may be needed, use a shielded wire, with one end connected to the antenna terminal and the other hung near the transmitter. Connect a capacitor in series with this wire to prevent accidental short circuits.

Chart I. Equipment Required for Servicing of Radio Receiver BC-683-A

1. Schematic Diagram of Circuit

2. Voltage Measurements

Multirange d-c voltmeter of at least 1,000-ohms-per-volt

Maximum range required: 0-250 volts

Intermediate range: 0-30 volts approximately

Low range: 0-3 volts approximately

3. Resistance Measurements

Ohmmeter with a maximum range of 5 megohms

4. Tube Tests

a. Suitable tube tester with short circuit tests, *or*

b. A second Radio Receiver BC-683-A in good condition, *or*

c. Complete set of new tubes.

5. Signal Tracing

a. Suitable signal generator, *or*

b. A second Radio Receiver BC-683-A in good condition, *or*

c. A Radio Transmitter BC-684-A in good condition.

Chart II. Servicing Procedure for Radio Receivers BC-683-A Not Mounted in a Vehicle

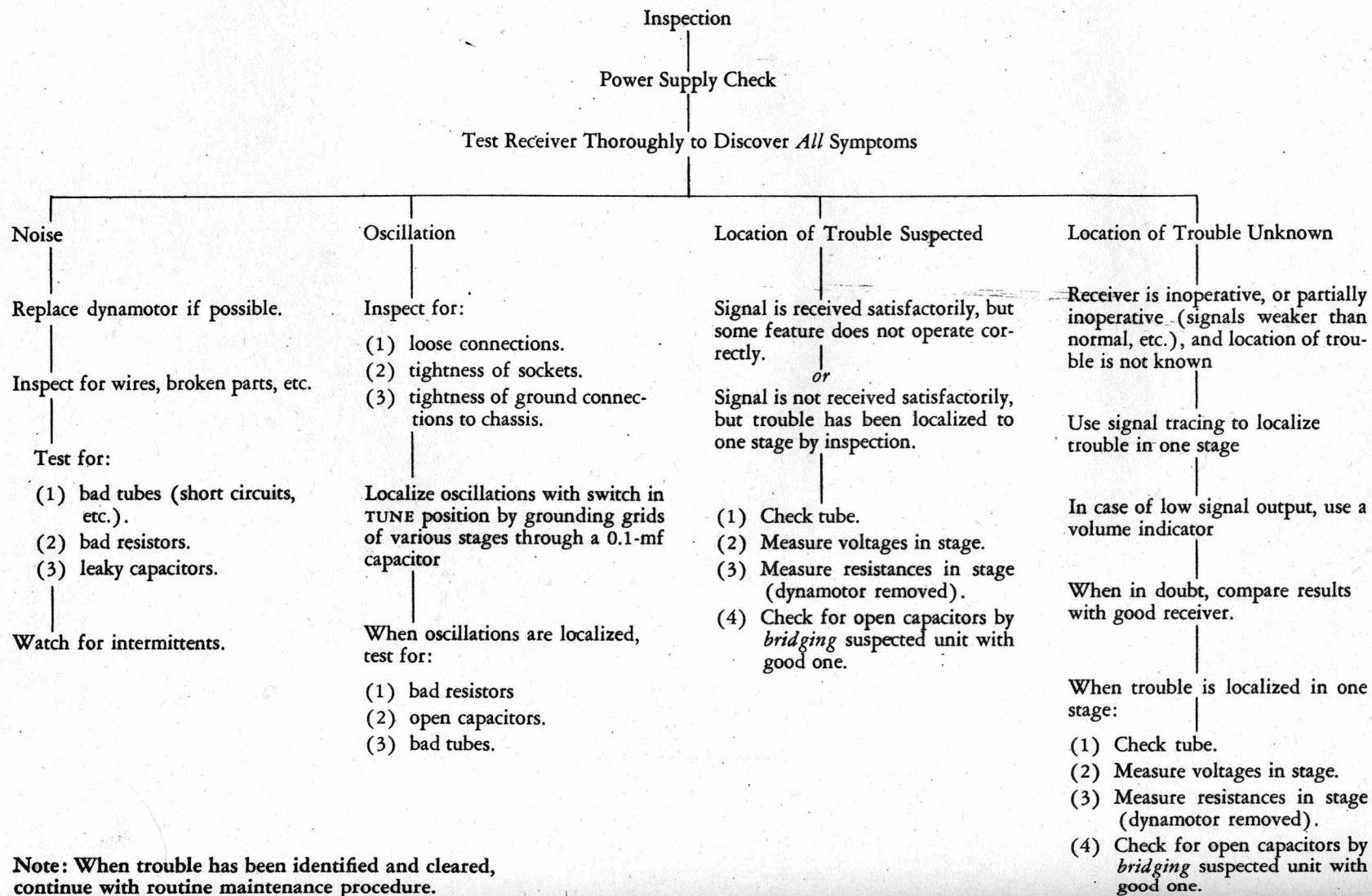
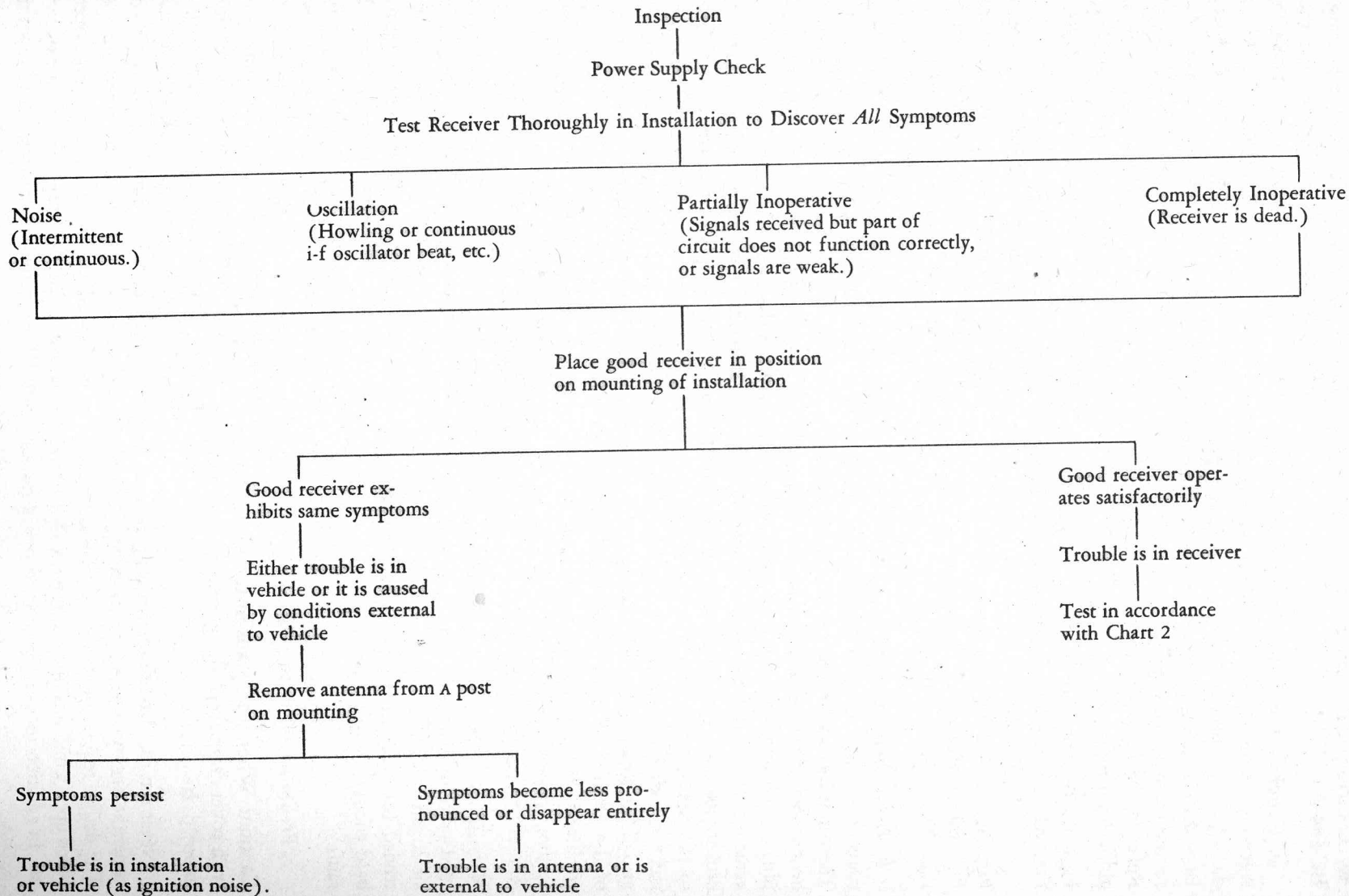

Chart III. Servicing Procedure for Radio Receivers BC-683-A Mounted in a Vehicle



40. Location of Trouble in Radio Transmitter BC-684-A.

a. General. The following procedure is designed to locate trouble quickly and with as little damage as possible to the transmitter. A report from the operating personnel on the trouble experienced will usually aid in making repairs. Refer to the following figures as an additional aid in locating trouble:

Figs. 47-50. Apparatus Location Diagrams.

Fig. 52. Location of Alignment and Tuning Controls.

Fig. 59. Voltage Diagram.

Fig. 60. Resistance Diagram.

Fig. 75. Wiring Diagram.

b. Inspection. Remove all covers from the transmitter and inspect for obvious defects. These may include broken parts, burned resistors, bent capacitor plates, bent pins on the connection plugs, or loose pieces of wire or metal. Smell for evidence of overheated parts. There may be broken gears, or the rack connecting the selector to the tuning capacitors may be out of alignment. Check for loose tubes or looseness in the grip of the socket receptacles on the contact pins of the tubes. Check for loose wires and repair any broken leads. Clean the inside, both top and bottom, with compressed air, paying especial attention to the selector mechanism.

Note: If an air hose is used, be sure any water condensed in it is blown out before applying the air stream to the equipment. Use only air intended for cleaning purposes and don't blow hard enough to dislodge or damage any apparatus.

c. Preliminary Precautions.

Caution: When the transmitter is operated with covers removed, dangerous voltages are exposed. *Be careful.*

Never run the dynamotor for long periods in either the RECEIVER TUNE or OPERATE position. The design requirements of the dynamotor are based upon 5 minutes operation with 15 minutes off. In addition to this, prolonged operation of

the set may cause objectionable heating effects within the transmitter. Never start the dynamotor with the transmitter ON-OFF switch (filament switch). Start the dynamotor with the RECEIVER TUNE-OPERATE switch or the microphone switch after the filaments have been heated for about 5 seconds (by closing the ON-OFF switch).

d. Power Supply Check. Lay the transmitter on its side with the panel up so you can read the meter and see the under chassis parts. Don't connect a microphone to the set.

Plug in auxiliary Cord CD-786 to connect the battery to the power receptacle on the transmitter. If the dynamotor starts, look for a stuck dynamotor relay or shorted relay contacts.

Turn the main ON-OFF switch to ON. The green signal lamp should light. If the lamp does not light, check for a burned-out pilot lamp or loose wiring at terminals 1 and 2 of PG101. Watch carefully for other obvious trouble as soon as the switch is turned on.

If desired, a voltmeter may be connected across the power supply during these tests. Operating the filament supply switch (Paragraph 40c) should not cause an appreciable change in the voltage reading if no trouble is present. If the dynamotor is short-circuited, the main fuse will open or there will be a continuous low-voltage reading when the dynamotor starts.

Assuming that the dynamotor does not start when the filament supply switch is operated and that no other trouble is noticed after operating the switch, connect a microphone to the set. Momentarily operate the microphone push button and note that the dynamotor starts. If the dynamotor does not start, inspect relay S102 for breakage, contact failure, or defective wiring. Inspect the dynamotor jacks and wiring. Check the dynamotor and also the microphone cord and jack. The dynamotor may start but may indicate by high-speed whine that it is operating at no load. Inspect for an open high-voltage fuse and other open-circuit trouble on the high-voltage supply leads. If the dynamotor starts but operates at low speed, check for a high-voltage overload. Remove the high-voltage fuse. If the dynamotor still labors, remove the battery cord from the set

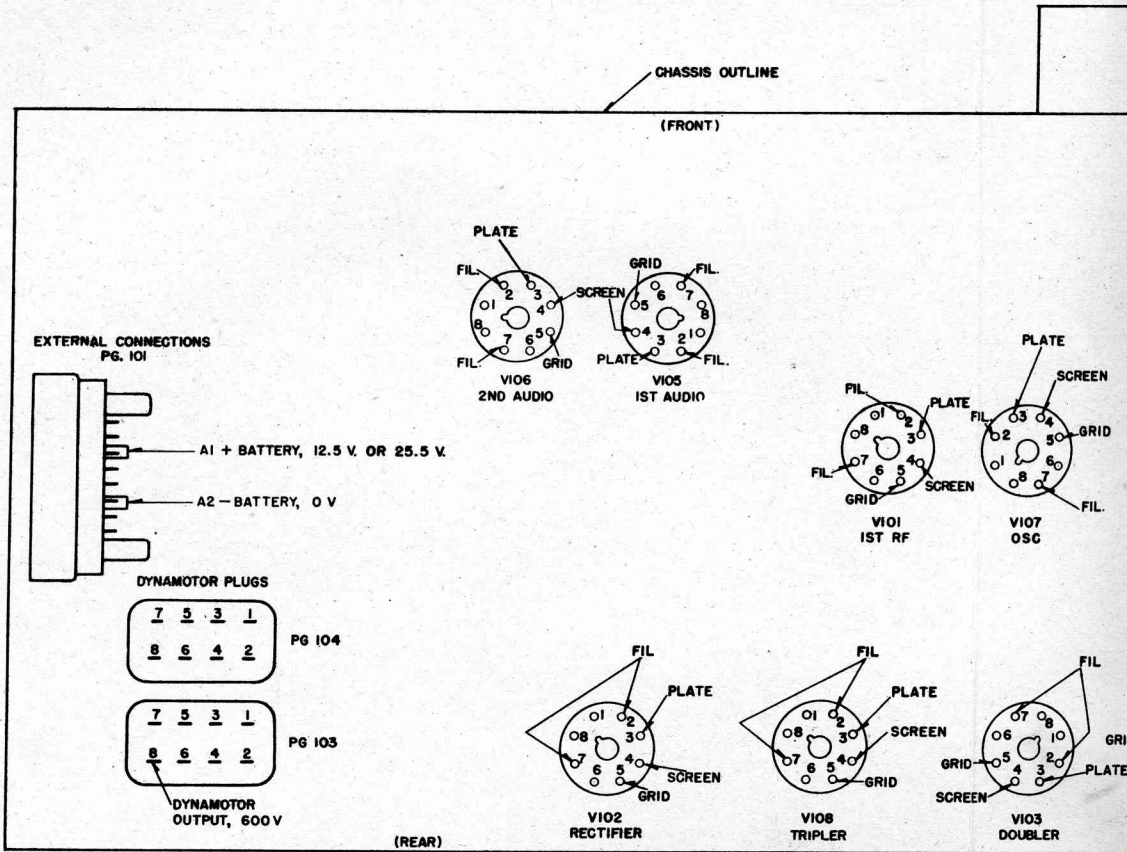

CAUTION: DANGEROUS VOLTAGES ARE EXPOSED.

NOTES:

1. LAYOUT CORRESPONDS WITH BOTTOM OF TRANSMITTER. DATA TAKEN WHILE TRANSMITTER IS OPERATING ON CHANNEL 330 INTO A 400 OHM LOAD. VOLTAGES ARE MEASURED FROM DESIGNATED POINTS TO FRAME OF TRANSMITTER.
2. OBSERVED METER READINGS MAY EXCEED THE VALUES SHOWN BECAUSE OF RF VOLTAGE SUPERIMPOSED ON DC VOLTAGE AT SOME POINTS.
3. MEASUREMENTS TO BE MADE WITH CRYSTAL OVEN THERMOSTAT UNOPERATED.
4. FOR VOLTAGE MEASUREMENTS, USE VOLTMETER SCALES AS FOLLOWS:
 - 0 - 3 V., 3 VOLT SCALE
 - 3 - 30 V., 30 VOLT SCALE
 - 30 - 300 V., 300 VOLT SCALE
 - 300 - 600 V., 600 VOLT SCALE

APPROXIMATE VOLTAGES AT VACUUM TUBE SOCKET TERMINALS									
MEASUREMENTS WITH VOLTMETER OF 1000 OHMS PER VOLT					MEASUREMENTS WITH VACUUM TUBE VOLTMETER				
TERM. NOS.	VIO1	VIO2	VIO3	VIO4	VIO5	VIO6	VIO7	VIO8	
1	0	0	0	2.5	0	0	0	0	
2	10	7.5	2.5	300	2.5	12.5	2.5	7.5	
3	400	400	400	-13	200	345	100	400	
4	130	245	160	-	22	180	80	270	
5	-75	-22	-15	0	0	0	-1.4	-4.5	
6	-	-	-22	-	-	-	-	370	
7	7.5	10	5	-	5	10	0	5	
8	0	0	0	-	0	0	0	0	
CAP	-	-	-	600	-	-	-	-	

Fig. 59. Radio Transmitter BC-684-A: Voltage Diagram

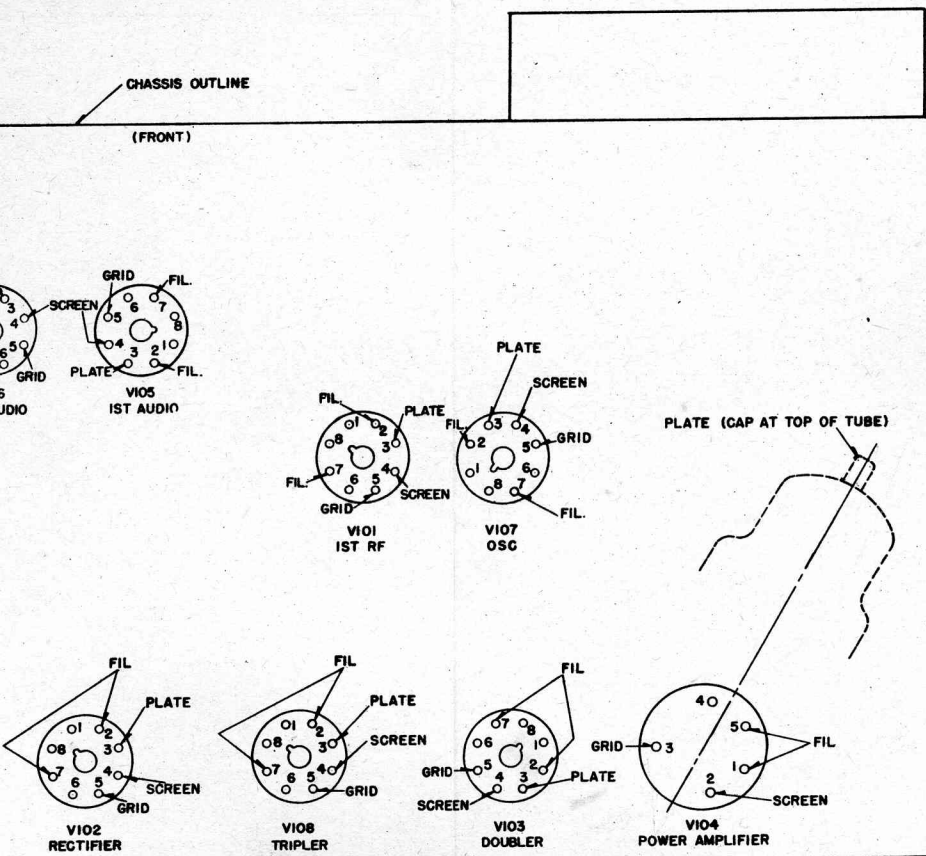

APPROXIMATE VOLTAGES AT PLUG TERMINALS		
12.5 VOLT BATTERY		
TERMINAL NOS.	PG 103	PG 104
1	0	12.5
2	0	12.5
3	0	12.5
4	-22	12.5
5	0	0
6	—	12.5
7	0	0
8	600	0
25.5 VOLT BATTERY		
TERMINAL NOS.	PG 103	PG 104
1	0	25.5
2	0	12.5
3	12.5	25.5
4	-22	25.5
5	0	0
6	—	12.5
7	12.5	0
8	600	0

CAUTION: DANGEROUS VOLTAGES ARE EXPOSED.

TER. DATA TAKEN WHILE TRANSMITTER IS OPERATING ON CHANNEL 330 INTO A 40 OHM ANTENNA. ALL POINTS TO FRAME OF TRANSMITTER.

VALUES SHOWN BECAUSE OF RF VOLTAGE SUPERIMPOSED ON DC VOLTAGE AT SOME TERMINALS. THERMOSTAT UNOPERATED.

SCALES AS FOLLOWS:
 0-3 V., 3 VOLT SCALE
 3-30 V., 30 VOLT SCALE
 30-300 V., 300 VOLT SCALE
 300-600 V., 600 VOLT SCALE

APPROXIMATE VOLTAGES AT VACUUM TUBE SOCKET TERMINALS									
VOLT	MEASUREMENTS WITH VACUUM TUBE VOLTMETER (RCA VOLTOHMYST OR EQUIVALENT)								
	TERM. NOS.	VIO1	VIO2	VIO3	VIO4	VIO5	VIO6	VIO7	VIO8
0	1	0	0	0	2.5	0	0	0	0
7.5	2	10	7.5	2.5	340	2.5	12.5	2.5	7.5
400	3	400	400	400	-90	220	370	120	400
270	4	180	270	180	—	40	220	85	290
-4.5	5	-90	-45	-60	0	0	0	-9	-60
370	6	—	—	-23	—	—	—	—	400
5	7	7.5	10	5	—	5	10	0	5
0	8	0	0	0	—	0	0	0	0
—	CAP	—	—	—	600	—	—	—	—

Fig. 59. Radio Transmitter BC-684-A: Voltage Diagram

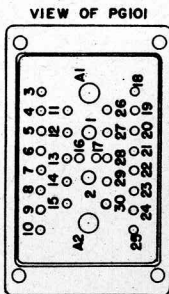

RESISTANCES AT PG101	
TERM.	OHMS
A 1	40
1	1
2	0
A 2	OPEN
3	OPEN
4,5	7.5
6,7,8	OPEN
9	310
10	OPEN
16,19	OPEN
20	OPEN
21	11,300
22,23,24	OPEN
25	22

EXTERNAL CONNECTIONS
PG101 (SEE TABLE)

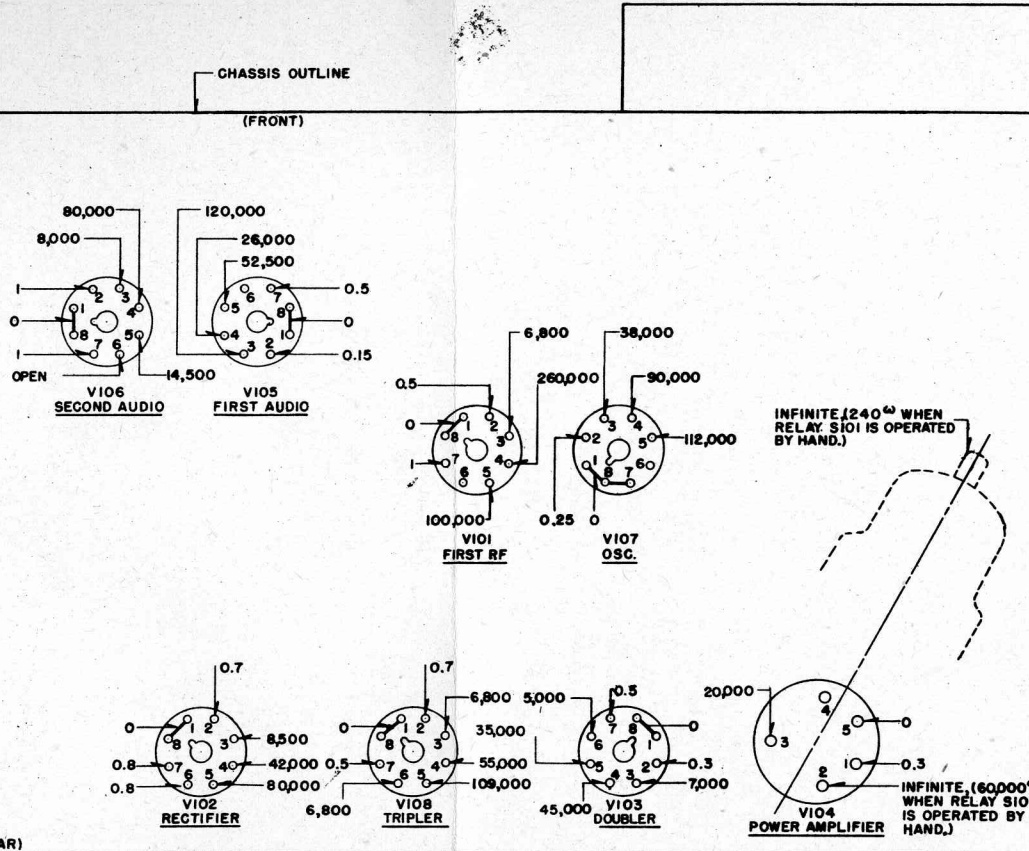
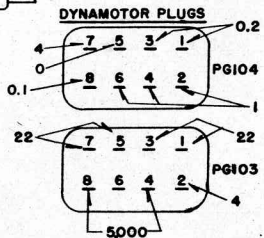
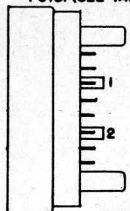

CAUTION: REMOVE BATTERY BEFORE MEASURING RESISTANCE

BOTTOM VIEW OF TRANSMITTER WITH COVER PLATE REMOVED. ALL VALUES SHOWN ARE OHMS BETWEEN POINT INDICATED AND FRAME OF SET. NO BATTERY CONNECTED. DYNAMOTOR IN PLACE. ON-OFF SWITCH ON. ALL VACUUM TUBES IN PLACE. RECEIVER TUNE-OPERATE SWITCH IN OPERATE POSITION.

Fig. 60. Radio Transmitter BC-684-A: Resistance Diagram

Table VI. Meter Switch Readings*

Switch position	1	2	3	4	5	6
Circuit	Doubler Grid	First R-f Grid	Rectifier Grid	Tripler Grid	Power Amplifier Grid	Total Plate and Screen
Meter reading (27.0 mc)	30	30	20	20	30	30
Meter reading (38.9 mc)	20	25	25	25	30	30

*Transmitter RECEIVER TUNE-OPERATE switch at RECEIVER TUNE.

and determine where the short circuit is and check the dynamotor.

e. Check of R-f Stages. Assuming that the dynamotor starts satisfactorily and that no other trouble is noticed upon operating the microphone push button, proceed to a rough check of the operation of the radio-frequency stages.

Check that all crystals are in place.

Caution: High voltage is present on the crystal pin-jacks when the transmitter is operating. Don't take chances.

Operate the push button for the highest frequency channel. Place the RECEIVER TUNE-OPERATE switch on RECEIVER TUNE and the TUNE-ANT CUR switch on TUNE. Turn the METER SWITCH on the right end of the transmitter to position 2 and observe the oscillator output to the first radio-frequency stage. This current will be considerably different for crystals of different activity. Any reading is probably satisfactory. (Note: This current may be high for sets with a 1000-ohm resistor R106; see Paragraph 44.) Operate the METER SWITCH successively to positions 3, 4, 1, and 5, observing the grid current to the rectifier, tripler, doubler, and power amplifier. The current readings given in Table VI may be used as a guide, but it is recommended (on account of possible wide tube and circuit variations) that the normal current readings for each transmitter be recorded for use in locating trouble. (Also see Paragraph 31e.) If you obtain a considerably different reading from that shown in Table VI at one point, your trouble may be near the point of such reading. Voltage and resistance readings in accordance with Figs. 59 and 60 should be made at the stage in which trouble is suspected to be present; if necessary, replace the tube in that stage. Low-voltage readings

indicate short circuits or high series resistance; high-voltage readings in general indicate defective tubes or open circuits or shorted series resistors.

Start the transmitter and check the selector adjustment by depressing the no. 1 push button and observing the maximum meter deflections with the METER SWITCH in positions 3, 4, 1, and 5, as the gang capacitor is varied slightly against the restoring force of the selector springs. Do not attempt to rotate the capacitor control more than a few degrees. The meter should indicate a maximum deflection at the capacitor setting determined by the selector. If the selector does not properly position the gang capacitor, it should be reset in accordance with Paragraph 21a. If the transmitter has been incorrectly tuned to the crystal frequency, incorrect peaking with METER SWITCH positions 1 and 3 will probably result. Improper alignment (assuming that the tuning was done properly) will probably result in low meter readings in positions 1 and 5.

Do not operate with the switch on RECEIVER TUNE for more than a few minutes at a time. If no trouble is indicated by the meter readings with the push button for the highest-numbered channel operated, take similar readings on the other channels in sequence.

f. Tuning Check. If your meter readings indicate need for tuning the channels, perform the tuning adjustments in accordance with Paragraph 21a and check as discussed in Paragraph 40e preceding.

g. Power Amplifier Check. To check the operation of the power amplifier, throw the RECEIVER TUNE-OPERATE switch to OPERATE. Throw the TUNE-ANT CUR switch to ANT CUR and see if the power output can be varied by

variation of the antenna trimmer capacitor. An antenna (see Paragraph 38*b*) must be connected for this test. Also read the plate current (METER SWITCH in position 6 and TUNE-ANT CUR switch on TUNE) with the RECEIVER TUNE-OPERATE switch first at RECEIVER TUNE and then at OPERATE (microphone button pressed). The difference in readings should give the normal power amplifier plate current. Watch for sparking and overheating in the power amplifier tube itself. If there is output from the preceding stage and none from the power amplifier, check the voltage and resistance readings for the stage and the tube itself. Also check alignment of the power amplifier stage.

b. Check of Audio Stages. Replace the bottom cover plate and place the transmitter on the mounting for check with the associated receiver. Turn the SIDETONE control to maximum. Speak into a microphone. Sidetone should be heard in the associated receiver. As an over-all check of the audio stages and the transmitter itself, operate the transmitter and listen on the receiver of another set. This should give a satisfactory check for both operation and noise in the transmitter. If there is trouble in the audio stages, make a voltage and resistance check of both stages. Operating the transmitter with its own receiver will also give you a satisfactory check of the operation of the control circuits.

i. Intermittent Trouble. Whenever a complete inspection of a transmitter is made, every effort should be made to locate and clear intermittent trouble. Do this by complete inspection of parts and wiring and by gently shaking or jarring the transmitter.

41. Maintenance of Dynamotors.

a. Service Tools. No special tools are required for the ordinary care of Dynamotors DM-34-(*), DM-35-(*), DM-36-(*), and DM-37-(*). The following tools and material are desirable:

- 1—3 1/2-inch cabinet screwdriver.
- 1—Small pair of pliers.
- 1—Toothbrush.
- 1—Clean cloth.

- 1—Can of light machine oil.
- 1—Can or tube of Type S-58 lubricant, or its equivalent.
- 1—Light hammer.
- 1—Center punch.
- A few sheets of grade 0000 (4/0) sandpaper.

b. Troubles and their Remedy.

(1) Failure to Start, or Dynamotor Stops:

<i>Possible Cause</i>	<i>Correction</i>
No d-c supply; open or loose connection.	Check d-c supply and tighten connections.
Brushes not seating properly; dirty, sticking, or worn brushes.	Remove brushes. Clean thoroughly and reseal or replace as required.
Poor commutation; dirty or rough commutator.	Clean commutator and brushes; if rough, sand with 4/0 sandpaper; turn commutator.
Worn bearings; armature strikes pole faces or connections.	Replace bearings.
Defective armature; short-circuited or open-circuited.	Replace dynamotor.

(2) Excessive Arcing at Brushes:

<i>Possible Cause</i>	<i>Correction</i>
Poor commutation; dirty or rough commutator.	Clean commutator and brushes; if rough, sand with 4/0 sandpaper; turn commutator.
Brushes not seating properly; dirty, sticking, or worn brushes.	Remove brushes. Clean thoroughly and reseal or replace as required.
Defective brush spring.	Replace brush assembly.
Short circuit between bars; dirty commutator.	Clean commutator, or replace dynamotor.
Open-circuited armature coil.	Replace dynamotor.

(3) Rapid Brush Wear:

<i>Possible Cause</i>	<i>Correction</i>
Excessive arcing.	See (2).
High mica.	Replace dynamotor.
Dirty commutator.	Clean commutator and brushes; smooth with 4/0 sandpaper.

(4) *Excessive Noise Picked Up in Radio Receiver BC-683-A:*

<i>Possible Cause</i>	<i>Correction</i>
Sparkling at commutator.	See (2).
Loose connections.	Tighten connections.
Capacitor open- or short-circuited.	Replace capacitor.

(5) *Excessive Noise and Vibration:*

<i>Possible Cause</i>	<i>Correction</i>
Armature striking internal wiring.	Rearrange wiring.
Armature striking pole pieces.	Replace dynamotor.
Worn bearings.	Replace dynamotor.

c. Routine Maintenance. If the radio equipment is operating normally, the dynamotors should need servicing (including lubrication) only about every 300 hours of use. The life of the dynamotor will be extended substantially if the end bells are removed and the dust wiped from the commutators and the brush holders every 100 hours or oftener. Unnecessary dressing of commutators, manipulating of brushes, or excessive greasing is likely to be harmful.

Note: In the following paragraphs, numbers in parentheses correspond to numbers in Figs. 41 and 42, exploded views of the two dynamotors, which are found on pages 67-68.

(1) *Lubrication.* Remove the end covers (13) by cutting the safety wires on the ends of the dynamotor and removing screws (14), washers (16), and lock washers (15). Wipe out loose dust and dirt. Take out the screws (28) holding the bearing bracket end plate (27) and remove the end plate, being careful not to lose any shims from the end of the shaft. With the toothbrush and cloth remove all old and hardened grease. Apply two or three drops of light machine oil to the ball bearings, and repack the outer side of the bearing with a small amount of Type S-58 lubricant as made by the New York and New Jersey Lubricant Company, or the equivalent. Do not get oil or grease on the commutator or brushes.

If there is grit in the bearings, you can clean them temporarily by removing the armature and swishing the bearings back and forth in cleaning fluid, such as petroleum spirits, kerosene, gasoline, or carbon tetrachloride. Be careful not to insert the armature far enough into the fluid to permit the windings to become wet. After cleaning, shake off as much cleaning fluid as possible, then insert the bearings into a bath of light machine oil, remove, and allow to drain before repacking with grease as outlined in Paragraph 41c(1).

(2) *Commutators.* A highly polished commutator surface is very desirable. Don't mistake a dark color for a burned condition. If the surface is smooth and is polished and the commutation satisfactory, leave it alone. Slight sparking does not necessarily mean poor commutation. If the surface of a commutator becomes dirty, wipe with a clean cloth. If necessary, wipe with a cloth moistened with cleaning fluid such as petroleum spirits, kerosene, or gasoline, followed by a dry cloth. Keep bearings and housing clean. Remove the covers and clean out the dust and dirt frequently. This cleaning should include removing the brushes and wiping the inside of the brush holders and the external surfaces of the brushes.

(3) *Brushes.* Each brush has a flexible pigtail and spring designed to limit the rotation of the spring and pigtail to a minimum when replacing a brush cap. Replace brushes when they are less than 1/4-inch long as measured from the bearing surface to the spring. Brush pressure is satisfactory if 1/4 inch or more of the spring extends out of the brush holder when the holder cap is removed and the end of the brush is bearing on the commutator. Run in new or re-dressed brushes for several hours at no load when possible, to obtain proper fit before the dynamotor carries full load. It is desirable that the brushes be so seated that they bear over 100 per cent of their arc and have at least 75 per cent of their area in contact with the commutator. When brushes are replaced after removal, be sure you return them to the same holders from which they were removed. Insert the brushes in their re-

spective holders with the polarity mark facing upwards. When checking or replacing brushes make sure they slide easily in the brush holder; if they do not, the spring cannot force the brush against the commutator.

It is very important to keep brush resistance

as low as possible, so make sure the brush pigtail is in good condition. If a brush pigtail is broken or loose in the brush or end cap, the current has a tendency to go through the brush spring. This causes the spring to overheat, lose its temper, and give low brush pressure.

WAR DEPARTMENT TECHNICAL MANUAL

TM 11-620

RADIO SETS

SCR-608-A AND SCR-628-A

WAR DEPARTMENT • 1 JANUARY 1944

SECTION V. SUPPLEMENTARY DATA

42. Replacement of Parts.

a. Mounting FT-237-(*)

(1) Method of Removing Coaxial Cables from L and T Connectors.

(a) Remove the covers from the rear and end channels of the mounting.

(b) Unsolder at the ground clips the ground wires running from the ferrule of the coaxial cable to the ground clips in the channel;

remove the varnished sleeving and bend the wires back from the channel.

(c) Remove the cover clips from the connectors and unsolder the connections inside the connectors.

(d) Loosen the Bristo set screw on the under side of the connectors, cut the tie strings which hold the coaxial cable in position, and pull out the coaxial cable and connectors from the rear channel.

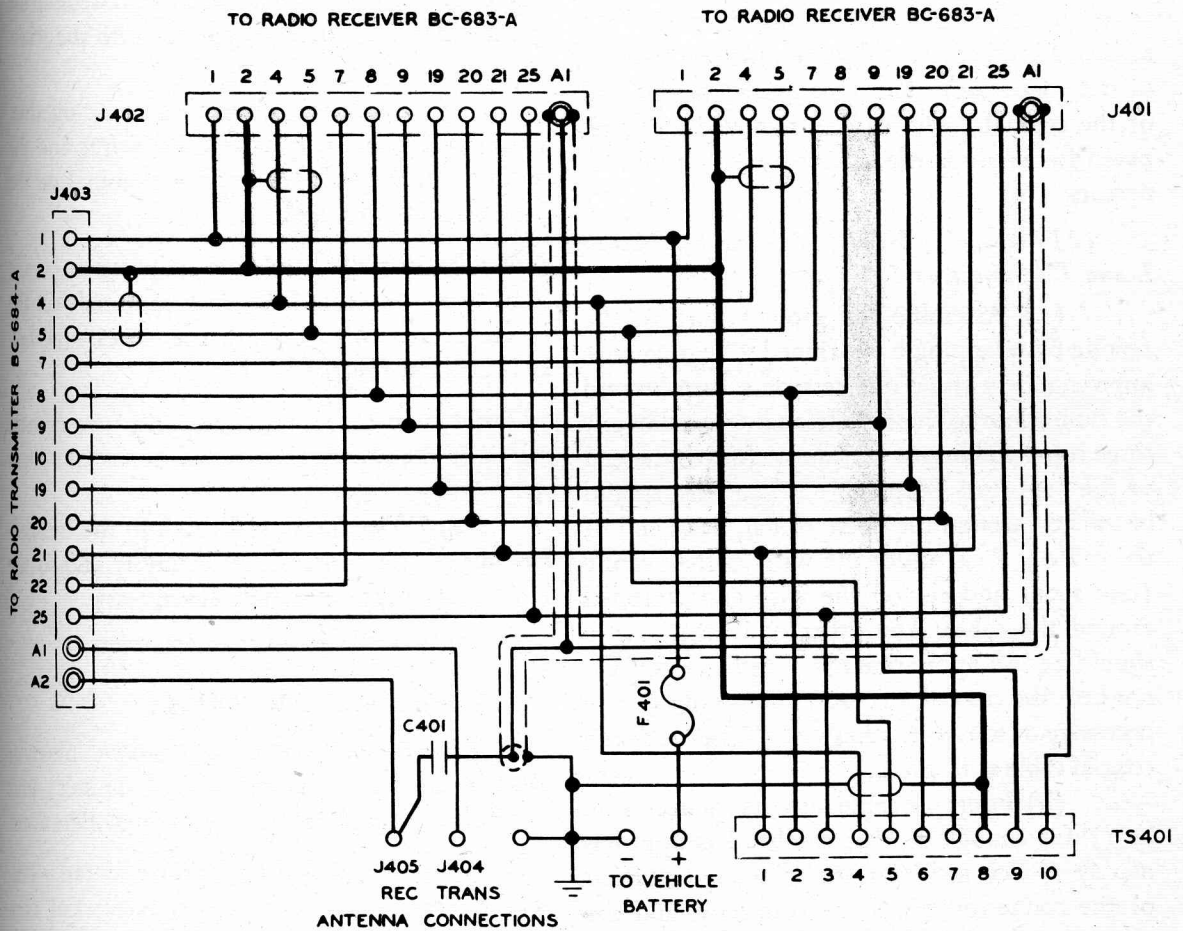

APPARATUS LEGEND

- C401 0.0001 UF 500V
- F401 75 AMPERE FUSE (W.E.66B)

JACKS

- J401 RECEIVER A CONNECTION

- J402 RECEIVER B CONNECTION
- J403 TRANSMITTER CONNECTION
- J404 TRANSMITTER ANT CONNECTION
- J405 RECEIVER ANT CONNECTION
- TS401 TERMINAL STRIP

Fig. 61. Mounting FT-237-(*): Schematic Diagram

(e) Cut the tie strings holding the coaxial cable in position in the end channel, unsolder the connection between the coaxial cable and the capacitor, remove the screw and nut from the coaxial cable ground clamp, and pull out the coaxial cable from the end channel.

(f) With the connector held in a pair of gas pliers in the left hand, place the connector against the tip of a 200-watt soldering iron (held stationary), and remove the cable from the connector by pulling with the right hand when the solder in the connector has been heated sufficiently to become fluid. Remove the excess solder from the connector by tapping it while hot against a solid object. (This permits ready re-use of the connector). The ground clip at the end of the coaxial cable may be removed and prepared for re-use in the same manner as for connectors.

(2) Method of Soldering Coaxial Cables to L and T Connectors.

(a) Assemble the ground wire to the ferrule by wrapping bare, tinned 22-gauge wire approximately three quarters of a turn around the cable close to the ferrule and approximately three turns around the ferrule as close to the end of the ferrule as practicable. (The wire should be twisted around the open, or flat, bead end of the cable.) Spot solder the wire to the ferrule (one spot) and cut off the wire end wrapped around the cable. The other end of the wire should be left approximately 3 inches long. Do not heat the coaxial any more than is absolutely necessary to solder it, otherwise the beads in the coaxial cable will soften.

(b) Insert the cable into the connector (L or T) far enough so that the bead is approximately $\frac{1}{8}$ -inch inside of the milled-out portion of the connector. Hold the connector and the cable in a vertical position; solder the ferrule of the cable and the ground wire to the connector, using a 200-watt soldering iron. Avoid unnecessary heating of the cable.

(c) With the cable in a horizontal position, solder the ground clamp to the ferrule at the end of the cable. To avoid twisting the cable, solder the ground clamp at approximately 90

degrees to the long axis of the portion of the connector having the Bristo set screw.

(d) Place the cable in a position adjacent to and approximately parallel with the rear channel. Assemble the varnished tubing on the ferrule ground wires and connect and solder the ground wires to the ground clip at the J401 and J402 receptacles.

(e) Place the coaxial cable in the channel, push the connectors into position on the radio-frequency terminals of the J401 and J402 receptacles, and tighten the Bristo set screws with a $\frac{3}{32}$ -inch Bristo hexagonal wrench. Assemble the ground clamp in the end channel with the screw and nut.

(f) Inside the connectors, twist together, solder, and clip the coaxial cable wires and the wires from the radio-frequency terminal on the J401 and J402 receptacles.

Note: Be sure the beads are in position on the wire from the radio-frequency terminals on the receptacles before twisting the wires together. If necessary, replace the beads.

Twist together, solder, and clip the coaxial wire and the capacitor terminal in the end channel.

(g) Tie the coaxial cable to the hexagonal nut of the plunger pin assembly and to the local cable (approximately seven ties).

(h) Replace the channel covers.

b. Radio Receiver BC-683-A.

(1) *Replacement of a Channel Selector Unit.* To replace a channel selector (tuner) unit in a receiver, perform the following operations.

(a) Connections to be Unsoldered.—Unsolder seven (sometimes eight) electrical connections at the tuner unit (channel selector) to release it from other receiver apparatus.

(b) Screws to be Removed.

(1) Remove the four screws releasing the front guard of the receiver.

(2) Remove the eight screws releasing the front panel.

(3) Loosen the five screws in the rear

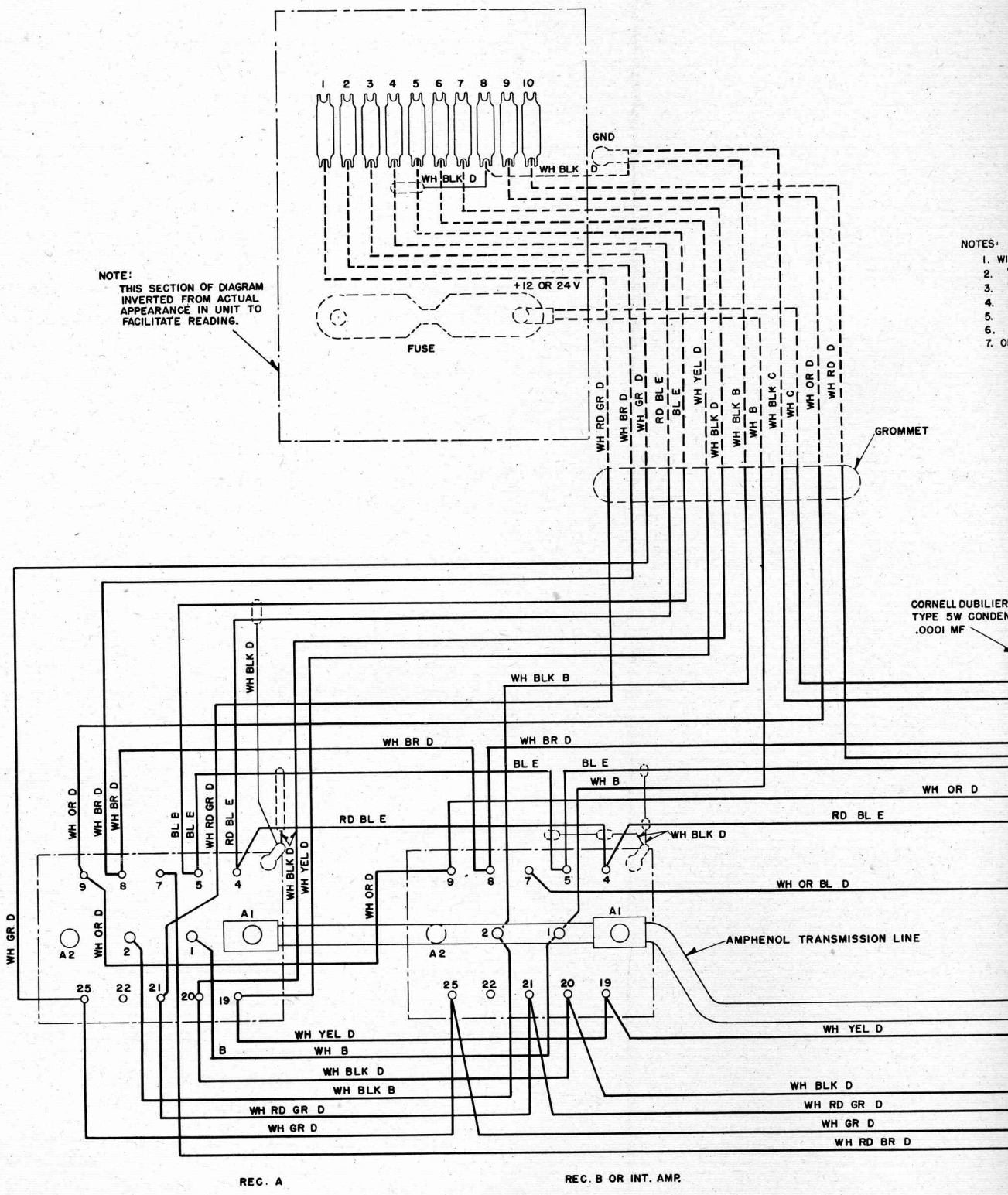

- NOTES:
1. WH
 2. "
 3. "
 4. "
 5. "
 6. "
 7. ON

REC. A

REC. B OR INT. AMP.

Fig. 62. Mounting FT-237-(*): Wiring Diagram

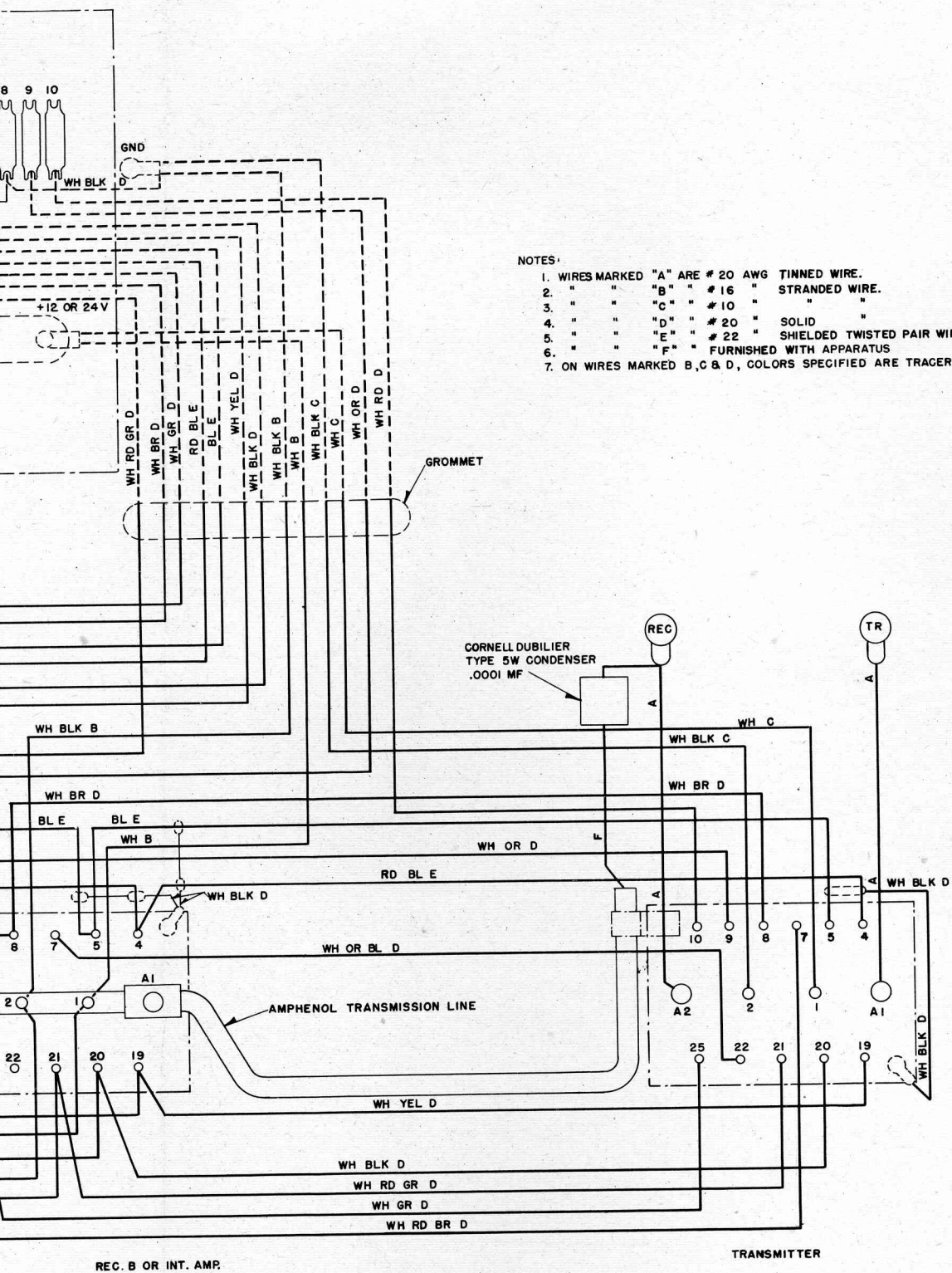

NOTES:

1. WIRES MARKED "A" ARE # 20 AWG TINNED WIRE.
2. " " "B" " # 16 " STRANDED WIRE.
3. " " "C" " # 10 " " " "
4. " " "D" " # 20 " SOLID " "
5. " " "E" " # 22 " SHIELDED TWISTED PAIR WIRE.
6. " " "F" " FURNISHED WITH APPARATUS
7. ON WIRES MARKED B, C & D, COLORS SPECIFIED ARE TRACERS ON WHITE WIRE.

Fig. 62. Mounting FT-237-(*): Wiring Diagram

of the tuner, releasing the tuner unit from the receiver chassis.

(c) Method of Replacing Channel Selector.

(1) With the front panel guard and front panel removed from the receiver, insert the tuner unit through the front panel opening into the chassis.

(2) Loosely fasten the unit to the chassis by five screws. *Do not tighten these screws.* See operation (5) for tightening.

(3) With the tuner loosely in place add the front panel with its apparatus, and fasten securely to the chassis (six screws) and the tuner unit (two screws).

(4) Add the front panel guard to the receiver, secure it firmly with four screws.

(5) Supplement operation (2) by securing the tuner firmly to the chassis with the five screws in the rear of the tuner. Be sure to follow this procedure of fastening the five rear screws as it avoids setting up a strain while tightening the two front screws which hold the tuner in position. (The six other screws which hold the front panel do not affect the tuner.) Such possible strain might permanently impair the accuracy of the tuner. Check to see that all push buttons operate smoothly and do not bind on the receiver panel.

(6) Resolder the seven (sometimes eight) electrical connections at the tuner unit.

(2) *Replacement of a Push-button (Plunger) Assembly in a Channel Selector.*

(a) Release the push button setting as described in Paragraph 21*b*. Release all push buttons.

(b) Screw Removal Operation.

(1) Remove four screws to release the front panel guard.

(2) Remove eight screws to release the front panel.

(3) Remove four flathead screws to release the tuner front plate and the latch-plate assembly.

(c) Removal of Latch-plate and Push-button Assembly.—Pull the lower end of the latch-plate assembly outward slightly. Grasp the

edges of the latch plate just behind the face plate and pull the latch plate downward. Pull the entire assembly outward gently to prevent jamming, and nurse the top end of the latch plate past the edge of the mounting bracket. Pull the assembly further until it separates from the connecting rods.

(d) Substitution of Push Button.—With the push buttons hanging downward, pull the latch plate back against its spring. Remove the faulty button and replace it with a new button making sure that the notch is in line with the notch on other buttons. Allow the latch plate to return to normal.

(e) Replacement of Latch-plate and Push-button Assembly.—Line up the latch-plate assembly with the connecting rods. Release the latch plate and mesh each button separately, starting at the top. When all are properly meshed, pull all buttons forward so that the latch plate can release and hold them. Push the assembly into place carefully by nursing the latch plate past the mounting bracket while the latch plate is pulled down. When it is in position, release the latch plate and replace the flathead screws to hold it in place. Replace the front panel and the front panel guard. Set the push buttons for the desired channels as described in Paragraph 21*b*.

c. Radio Transmitter BC-684-A.

(1) *Replacement of a Channel Selector Unit.* To replace a channel selector (tuner) unit in a transmitter, perform the following operations.

(a) Connections to be Unsoldered.

(1) Unsolder the short and long coaxial cables at antenna post A on the rear of the front panel. Also unsolder R155 from this post.

(2) Unsolder the short coaxial cable at the antenna relay S101.

(3) Unsolder at the relay (S101) the capacitor (C161) which connects a long coaxial cable to this relay.

(4) Unsolder, at the relay, the bare wire which connects the top of the L111 coil to the antenna relay.

(5) Unsolder, at the bottom of the L110 output coil, the bare wire (covered with varnished tubing) which leads to the power amplifier screen resistor (R114) located in the bottom compartment of the chassis. Also unsolder the black-red wire leading from the coil to the local cable of the transmitter.

(6) Unsolder, at the insulated stud E, the bare wire leading to the bottom of the left-hand tuner contact spring assembly.

(7) Unsolder, at the crystal oven, the ten electrical connections to the tuner spring contact assembly.

(b) Screws to be Removed.

(1) Remove the screw on top of the selector to release the ground terminal lug and wire leading to ground post G on the rear of the front panel.

(2) Remove six screws from the thermocouple, releasing it from its electrical connections and mounting.

(3) Remove the screw which secures the ground lug to the top of the tuner,—the lug to which the ground wires leading to the short and long coaxial cables ferrules are connected.

(4) Remove the screw from the top of the tuner, releasing the clamp that holds the long coaxial cable in place across the top of the unit. Carefully bend this cable to the left so that it will not interfere with vertical movement of the tuner.

(5) Remove four screws, releasing the antenna relay (S101) from its location. Rotate the relay upward and to the right.

(6) Remove the gear from the bottom end of the tuner shaft by loosening the set screws with the Bristo wrench, and remove the rack connecting the tuner to the six-gang capacitor.

(7) Remove the three screws at the base of the tuner, releasing it from the chassis.

(8) Remove the four screws in the panel guard and remove the guard; unscrew the seven front panel screws and rotate the panel about its right-hand edge (where cables are located) to remove the panel apparatus from the panel opening. Lift the channel selector unit out through the top opening of the transmitter.

(c) Method of Replacing Channel Selector.

(1) With the front panel guard removed and the front panel swung out of the way, insert the selector unit into the chassis through the top opening of the transmitter.

(2) Loosely fasten the unit to the chassis by the three screws applied into the base of the selector through the bottom opening of the transmitter.

(3) Repeat, in reverse order, the remaining steps of (a) and (b) preceding with the exception of (b)(6).

Caution: When fastening the tuner firmly in position (after the front panel and its apparatus have been secured to the transmitter), observe that the tuner shaft rotates freely; if it does not, loosen the three mounting screws and shift the tuner until the tuner shaft is free to rotate without binding action. When locating the front panel and the tuner in position, be sure the push buttons do not rub in the panel openings.

(4) With the six-gang capacitor fully engaged and the pin (on the disk by which this capacitor is manually rotated) resting against the front stop in the semicircular opening in the right end of the chassis, and with the single-section tuning capacitor at the top of the tuner also fully closed (maximum capacitance), insert the gear on the tuner shaft, assemble the rack in place, and securely tighten the set screw on the gear. Note that the rack is centrally located and that it moves freely back and forth over its total travel.

(2) *Replacement of Capacitor Assembly (Including Six-gang Capacitor and Trimmer Capacitors).* To replace a capacitor assembly in a transmitter, perform the following operations.

(a) Connections to be Unsoldered.—Unsolder, through the bottom opening of the transmitter, all wires connecting to the six-gang capacitors.

(b) Screws to be Removed.

(1) Remove, at the left-hand end of the gang capacitor, the screw which holds a bracket and insulated terminal in place.

(2) Through the bottom of the transmitter remove four screws from the trimmer capacitor assembly bracket, releasing the entire capacitor assembly from the chassis.

(c) Replacement of Capacitor Assembly. —Remove the capacitor assembly, replace with a new unit, and reassemble in reverse order from (a) and (b).

(3) *Replacement of Gang Capacitor in the Gang-capacitor Assembly.*

(a) Repeat operations of (2) (a) and (2) (b) preceding to release the entire capacitor assembly from the transmitter chassis.

(b) Unsolder all electrical connections between the six-gang capacitor assembly and the trimmer capacitors.

(c) Remove four elastic stop nuts on the six-gang capacitor assembly to release the bracket on which the associated trimmer capacitors are mounted.

(d) Separate the six-gang capacitor from the trimmer capacitor assembly bracket released by the stop nuts.

(e) Replace the six-gang capacitor with a new unit and reassemble, with the trimmer capacitor assembly, into the transmitter chassis.

(4) *Replacement of Trimmer Capacitor Assembly.*

(a) Repeat the operations of (3) (a) and (3) (d) preceding.

(b) Replace the trimmer capacitor section with a new unit and reassemble, with the six-gang capacitor assembly, into the transmitter chassis.

(5) *Replacement of a Push-button (Plunger) Assembly in a Transmitter Channel Selector.* To replace a channel selector push button in a transmitter, perform the following operations.

(a) Unsolder the long and short coaxial cables at antenna post A on the rear of the front panel.

(b) Remove the screw from the frame at the top of the selector unit to release the ground terminal wire leading to ground post G on the rear of the front panel.

(c) Remove the tie-string which supports the short coaxial cable in the position near the left-hand post of the panel meter.

(d) Remove the four screws holding the front panel guard.

(e) Remove the seven screws holding the front panel and rotate the panel outward about its right-hand edge.

(f) Remove the four screws on the tuner front plate and latch-plate assembly in order to release the push buttons.

(g) Pull the defective plunger (push button) forward to separate it from its associated rod.

(h) Replace plunger and reassemble.

(6) *Removal of Tuning Coils in Low Power Stages.*

(a) Unsolder the leads to the upper and lower terminals of the defective coil winding (L106, L107, L108, L118, or L119).

(b) Break the Glytral seal at the bottom of the cylindrical metal tube in the top compartment.

(c) Unscrew the metal tube from the coil form.

(d) Remove the coil winding assembly from the chassis by withdrawing it from its location hole into the bottom compartment of the transmitter.

(7) *Removal of Coaxial Cable Terminals from Plug PG101.*

(a) Unsolder the ground straps between the coaxial cable ferrules and the chassis.

(b) Remove two screws and hexagonal nuts from each end of the plug to release the two metal plates (clamps) that hold the cable terminals in place.

(c) Remove the metal clamps and pull the cables and terminals from their locations in the plug.

43. Modifications during Manufacture.

a. General. The radio equipment described in this manual has been produced in large quantities over a relatively long period of time. Dur-

ing this period the equipments have been under continual study in the manufacturing plants and in the field. Some changes in the equipment have resulted from these studies. By far the greatest number of changes has been due to the necessity of using a different material, or a part from a different manufacturer. In general, you will find that the units which comprise your radio set will differ in some slight respect from other similar units bearing the same order number.

This apparatus has not only been made in large quantities but also has been constructed by a number of different subcontractors, which means that there may be minor differences in construction or parts. Watch for these variations although in most cases they will not affect servicing procedure.

Changes in materials or in the source from which similar parts are obtained do not in general affect the servicing procedure, so this type of change is not described in this manual. Circuit and apparatus changes which should be known to aid the proper servicing of the unit are described in some detail in Paragraph 43*b* for the receiver and Paragraph 43*c* for the transmitter.

Figure 70 is a schematic diagram of the receiver showing how it was before these changes were made. The parts that have been changed are crossed out and the new arrangements shown. Figure 73 gives corresponding information for the transmitter.

If you wish to make any of these changes in an earlier equipment and if the change has been authorized, all the items listed under a particular minor heading in the change must be made as a group in order to obtain the desired improvement.

b. Radio Receiver BC-683-A.

(1) *Changes Affecting R17 and R19.* R17 has been changed from 1 megohm to 0.25 megohm. R19 has been changed from 1 megohm to 2 megohms. The purpose of this change was to increase the voltage on the CALL SIGNAL lamp.

(2) *Changes Affecting L72 and L71.* In earlier drawings these two inductors were shown interchanged. L72 should be the primary wind-

ing in the plate circuit of V5. L71 should be the secondary winding in the grid circuit of V6.

(3) *Changes Affecting C11.* C11 has been reduced from 0.01 to 0.006 microfarad. The purpose of this change was to reduce the number of 0.01-microfarad capacitors.

(4) *Changes Affecting C82 and C20.3.* C82 has been reduced from 0.01 to 0.006 microfarad. C20.3 has been connected in parallel with C82. (It was previously in parallel with C20.2.) The purpose of this change was to reduce the number of 0.01-microfarad capacitors. It was found that the audio-frequency impedance of the circuit at the points across which C82 is connected should be reduced to improve circuit operation. This was accomplished by connecting C20.3 across C82 after which C82 could be reduced. It was found, also, that when C20.3 was so connected, the stability of the circuit was better than it had been with C20.3 connected across C20.2.

(5) *Changes Involving R8, R21, R71, R72, R74, and C71 (Limiter Characteristics of V5).*

R8 has been increased from 20,000 to 70,000 ohms (1/2-watt type).

R21, which is a 30,000-ohm (2-watt) type, has been added.

R71 has been increased from 100,000 ohms to 250,000 ohms.

R72 has been decreased from 43,000 ohms to 30,000 ohms.

R74 has been decreased from 10,000 to 1,000 ohms (1/2-watt type).

C71 has been decreased from 100 to 50 micromicrofarads.

These wiring changes were desirable because, on very strong signals, the output of the limiter previously fell off so much as to interfere with the operation of the squelch circuit under some conditions. In addition, the changes improved the reception of weak signals through high noise levels. In general, the changes were:

To make the second intermediate-frequency amplifier, V5, a more effective limiter by lowering screen and plate voltages. This involves R8 and R21 and a change in the plate return of V5. R74, formerly 10,000 ohms, could be reduced to 1000 ohms as drop in this resistor was no longer re-

quired. R71 was increased to improve the limiting action. This necessitated reducing C71 to maintain the proper time constant. R72 was decreased to obtain optimum load cross L71.

To remove the second intermediate-frequency amplifier from the influence of the delayed-automatic-volume-control circuit. This improved reception through strong noise. It involved moving the grid return of V5 from the automatic-volume-control circuit to the negative end of the dynamotor.

These changes are indicated graphically in Fig. 70 which shows the old arrangement crossed out and the new arrangement added.

The actual changes in wiring are as follows:

- (a) Move one pigtail of R8 from terminal 5 of FL2A to terminal 2 of FL2A.
- (b) Remove a wire (covered with a black sleeve) from terminal 6 of VS5 and terminal 5 of FL3A.
- (c) Connect one pigtail of R21 to terminal 5 of FL2A and the other pigtail to terminal 5 of FL3A.
- (d) Remove the green (tracer) wire from terminal 4 of VS9 and connect it to that terminal of C25 to which the blue (tracer) leads are connected.
- (e) Add a blue-brown (tracer) wire from terminal 5 of FL3A to terminal 5 of FL4.

(6) *Change Involving C44.* This 30-microfarad capacitor in the radio-frequency oscillator circuit was changed from silver mica to an N-080 Ceramicon. The change was made to improve temperature stability.

(7) *Change Involving C26.* C26 has been reduced from 0.001 to 0.0005 microfarad. This was done to permit the use of a ceramic capacitor as an alternate. This change also improved the operation of the beat oscillator by reducing the pull-in at low frequencies.

(8) *Changes in Capacitors of Dynamotors.* In Dynamotors DM-34(*) and DM-36(*), all the filter capacitors in some units have been reduced from 0.005 to 0.003 microfarad. No reduction in circuit performance results from this

change. Where a replacement problem involves a substitution of a filter capacitor, either a 0.003 or a 0.005-microfarad unit may be used in any position in the dynamotor without regard to the capacitance of the remaining units, but the replacements must meet the voltage rating prescribed in Paragraph 45, Table of Replaceable Parts.

(9) *Change in C35.* This unit was reduced from 0.01 to 0.006 microfarad.

(10) *Changes Affecting C53, C54, C55, C56, C63, C64, C65, C66, C73, C74, C75, C76, C84, C85, C86, C87, C88.* These changes are tabulated as follows:

Filter	Original Unit	Capacitance Value	
		Original	Replacing
FL1A	C53 and C54	*50 + †10	‡60
FL1A	C55 and C56	†10 + *50	‡60
FL2A	C63 and C64	*50 + †10	‡60
FL2A	C65 and C66	†10 + *50	‡60
FL3A	C73 and C74	*50 + †10	‡60
FL3A	C75 and C76	†10 + *50	‡60
FL4	C84, C85, and C86	†5, *50, and *50	‡60 and ‡60
FL4	C87 and C88	*25 + †10	‡35

*Silver-mica.
 †Ceramic N-680.
 ‡Ceramic N-080.

In filter units FL1A, FL2A, FL3A, and FL4 of the receiver, small ceramic capacitors were used originally in combination with silver-mica capacitors to provide temperature-compensated tuning capacitances. In later equipments these combinations of two capacitors have been replaced by single ceramic units each having capacitance and temperature compensation equal to those of the combination which it replaced. This is possible because a ceramic capacitor can be provided with any desired temperature coefficient (over a substantial range of positive and negative values). The single ceramic capacitor may be used as a direct replacement for the combination or vice versa. All the changes listed here fall in this class. Most of them are combinations where two units were in parallel and the changes involved a single ceramic with capacitance equal to the sum of the two and a temperature coefficient equivalent to their combination. In FL4, however, C85 and C86 (each a 50-micro-

farad silver-mica capacitor) were in series and C84 (a 5-micromicrofarad Ceramicon) was in parallel with the combination, making a total of 30 micromicrofarads. C85 and C86 have been changed to 60-micromicrofarad Ceramicons with the desired temperature coefficient which makes C84 unnecessary.

(11) *Change in Designation of Switch D2.* Switch D2 on the receiver was originally designated RADIO & EXT-EXT ONLY. This designation was changed to OUTPUT TO PHONES ON-OFF to provide a better conception of the function of this switch.

(12) *Change to Sealed Unit LCU3-C.* LCU3-C units are sometimes supplied as spare parts in place of LCU3-A units to replace the LCU3-A oscillator unit. The LCU3-C unit is essentially the same as the LCU3-A unit, except that it has been sealed to exclude moisture, thereby improving frequency stability of the receiver under high humidity conditions. The terminal numbers molded in the bakelite seals of the LCU3-C unit correspond to the terminal numbers of the unsealed LCU3-A unit.

If difficulty is encountered with frequency stability of a receiver under high humidity conditions, replace the LCU3-A unit with an LCU3-C sealed unit as follows:

Wire the LCU3-C unit in place without disturbing the cap. The adjustable slug of the LCU3-C unit has been preset at the factory and should seldom require adjustment during the alignment procedure. The capacity trimmer C1.7 should be adjusted for dial tracking at 38 megacycles and the dial tracking checked at 28, 32, and 35 megacycles. In many instances a slight readjustment of C1.7 will improve alignment.

A maximum dial tracking error at any frequency of three-fourths channel division is considered quite satisfactory providing the maximum error at the other two check frequencies is less than one-half dial division. When dial errors somewhat in excess of these values are found, they can frequently be tolerated; in such cases, it is preferable to avoid tampering with the seal of the unit, even though the tracking is not all that might be desired.

Caution: This unit is sealed against moisture. Do not remove the cap unless absolutely necessary.

Should a slug adjustment at 28 megacycles be found necessary, use the following procedure:

- (a) Find as dry a place as possible.
- (b) Run the receiver about an hour with the dust cover in place to warm the unit.
- (c) To remove the cap, heat the single point solder seal of the cap with a soldering iron while exerting a turning motion on the cap.
- (d) Complete the alignment as quickly as possible.
- (e) Replace the cap and re-solder in place.
- (f) If the cap was off for more than five minutes, run the receiver at least an hour with the dust cover in place and the cap off the unit.
- (g) Remove dust cover, replace cap, and re-solder.

c. Radio Transmitter BC-684-A.

(1) *A Change that Should be Made in Existing Equipment: Fuse F101.* Fuse F101 should be of 1/2-ampere rating. Some of the early equipment had 1-ampere fuses which do not always give adequate protection. One-half ampere fuses (as supplied in the spare parts groups) should be substituted for any 1-ampere fuses in this position.

(2) Changes in Parts.

(a) Change in C147.—The unit used in later production is a ceramic-type capacitor of cylindrical form covered with a black bakelite finish. This is the preferred replacement part. It is specified with plus or minus 2 per cent tolerance and rated at 800 volts, working. If it cannot be obtained it is satisfactory to use the single 175-micromicrofarad unit of the C-D Type 1R capacitor or four 175-micromicrofarad units of the C-D Type 5R capacitor in series-parallel. It is *not* satisfactory to use a single C-D Type 5R unit.

(b) Changes in Dynamotor Relay S102.—This relay has been changed from a Type AO to a Type BO relay with increased contact pres-

sure in the operated position. The latter unit is preferable but either can be used as available.

(c) Change in R107.—R107 was changed from 1/2-watt to 1-watt rating at 30,000 ohms in order to care for the higher current taken by some vacuum tubes.

(d) Changes in Resistors R119 and R155.—Two resistors R119 and R155 were originally specified as IRC Type F resistors. The IRC BT or BW types are just as satisfactory at these places and are or may be used interchangeably with Type F. The BT and BW types are preferred, however, because they mount in the transmitter more easily and with less chance of short-circuiting to adjacent parts or the chassis.

(e) Changes in Capacitors C138 and C142.—Capacitors C138 and C142 have been obtained from a number of different manufacturers and therefore it will be found that the "common" terminal (marked C on the capacitor can and in the wiring diagrams) will be located at one end of some capacitors and on the other end of other capacitors. Be careful in replacing a capacitor of this type to see that the C terminal is connected to the proper wires as shown in the wiring diagram of the transmitter.

(f) Changes in Transformers T101 and T102.—Some of these transformers were wound in the reverse direction from the majority. In many instances this will not cause poor operation but in some transmitters a reverse-wound transformer will be indicated by a high noise level on the radio carrier or on the interphone output. This can be cured by reversing (interchanging) the leads (red and blue) to terminals 5 and 6 on transformer T102. Transmitters using reversed transformers will have the wires interchanged at these terminals. Replacement transformers should be checked in this respect.

(3) Changes in Arrangement.

(a) Change in Connections of C122 and C123 and Addition of L123.—C122 was connected previously from the screen of V104 (power amplifier) to ground. Its ground terminal has been moved to the ungrounded side of the filament of V104. C123 was connected previously

from the ungrounded side of the filament of V104 to ground. It has been changed to connect between ground and the filament of V103. L123 has been added in the filament lead between V103 and V104. The purpose of these changes was to eliminate a tendency to spurious oscillation at very high frequency, which occurred in tube V104 of a few transmitters if a selector button was not depressed.

(b) Change in R118 and Addition of R162 and R163.—R118 has been changed to decrease the power dissipated in it. It was a 30,000-ohm, 2-watt unit, but has been changed to a 100,000-ohm, 2-watt unit, shunted by two other similar units (R162 and R163) mounted in the same resistance group. Thus the total resistance of the combination is not greatly changed but the power capacity is substantially increased. If a field replacement becomes necessary, it is desirable to use three 100,000-ohm, 2-watt units if possible. If they are not available a single 30,000-ohm, 2-watt unit may be used until the 100,000-ohm, 2-watt units can be obtained.

(c) Change in R102 and R107 and Addition of R160.—Some manufacturing variations caused the total current through dropping resistors R102 and R147 to exceed the allowable dissipation in these resistors. The later production units, therefore, were changed to add another resistor, R160, so that the three resistors could reliably dissipate the maximum heat. The total resistance of the three units was kept the same by reducing R102 and R147 from 1000 ohms each to 667 ohms each. R160 is 667 ohms.

(d) Change in R111 and Addition of R161.—R111 was changed from 15,000 ohms to 30,000 ohms, and R161 (30,000 ohms, 1 watt) was added in parallel to care for the increased grid current occurring with some tubes.

(e) Change in L106, L107, C111, C112, and Addition of C164.—During production it was found that some variations in wiring caused the coupling between L106 and L107 to be decreased below a suitable value. This was corrected by interchanging the coils and adding C164. The wiring changes are shown in the wiring diagram, Fig. 75. In the revised circuit some

of the coupling is obtained by mutual inductance between the two coils and additional coupling is obtained by the capacitor network C164, C111, and C112. It will be noted in the wiring diagram that in order to assure satisfactory operation, the leads to C111, C112, and C164 must be held to the length indicated. The tolerances of these capacitors must be held to those shown in Paragraph 45, Table of Replaceable Parts. If these capacitors are properly placed as shown by the wiring diagram and the leads correctly dimensioned, there should be no trouble in making this change in the field. This change need not be made in transmitters which are operating satisfactorily.

(f) Change in Wiring of R109.—One end of R109 was formerly connected to the bottom terminal of L106. This connection was moved in later transmitters to terminal 6 of VS108 in order to reduce the current through resistor R157.

(g) Shortening of Studs E and F and Relocation of L117-R149.—In the early production these studs were longer than necessary. This excess length produced coupling which caused poor oscillator operation in a few cases. Along with the shortening of the studs there were some wiring changes which are discussed in paragraph (3) following. The arrangements can be visualized by reference to Figs. 50 and 75. If this change is found necessary it will be facilitated by inspection of a late model transmitter as a guide. The steps in making the change are as follows:

(1) On stud F, interchange the top and bottom halves of the stud insulator and clip off the unnecessary part of the stud at the under side.

(2) On stud E, interchange the top and bottom halves of the stud insulator and clip off the unnecessary part of the stud at the under side.

(3) The coil-resistor combination (L117-R149) was previously connected from the end of stud E to R101 (the end away from the chassis). It crossed L102 on the side away from the chassis. This unit should be reconnected from the shortened stud E to R101—the end

nearest to the chassis. The wire previously connected to that end of R101 should be removed and reconnected to R101 at the end away from the chassis. With this rearrangement the coil-resistor combination passes between the chassis and coil L102.

(4) The two wires coming to L102 should be interchanged.

(h) Arrangement of Thermocouple Connections.—In order to permit adjusting the antenna current (TUNE-ANT CUR) meter reading over a wider range, the slide-wire adjustment was removed from between the terminals of the thermocouple and placed between the ends of the short coaxial transmission line connecting the antenna relay and the antenna binding post (A) on the front panel of the transmitter. This change cannot be made unless the replacement metering length of coaxial line is available. In installations where the antenna current reading on M101 is too low for convenient use, the reading may be raised by unsoldering the thermocouple slider tap and moving the tap to increase the reading. Take care that the antenna current reading will not go off scale under the highest voltage conditions. If the antenna current reading is too high, the direction of change should be reversed. This adjustment is most effective with the newer type arrangement of the thermocouple circuit.

(i) Meters and Thermocouples.—Meters from three manufacturers and thermocouples from two manufacturers have been used in the transmitters in order to maintain production when the meter or thermocouple from any one manufacturer became temporarily unavailable. Any of the meters and thermocouples will operate satisfactorily in a transmitter although there may be an inconsequential difference in meter readings when different meters are substituted, and the slide-wire tap may need slight adjustment when different thermocouples are substituted. The Weston thermocouples are somewhat faster in operation than the vacuum type marked with a number (ES-680241-7). The Weston meter originally had three connection studs, the two top ones going to the meter movement, the lower one going to the scale plate and magnet.

The lower stud is not and should not be used (see the wiring diagram, Fig. 75). In later meters this third stud has been eliminated. During the change-over from three to two studs, a number of the meters (about 1000) were incorrectly constructed to include a strap connection from the moving coil to the magnet and scale plate. This does not affect its operation at the TUNE position of D121 nor its operation with vacuum thermocouples for ANT CUR position of D121. However, in some transmitters a Weston meter having the incorrect connection may not operate properly with a Weston thermocouple. This will be indicated by very sluggish action of the meter when the antenna trimmer (usually at the highest frequency) is tuned. The meter reading will not drop to low values as it should when the antenna circuit is detuned by the trimmer. The approximately 1000 transmitters which have the incorrectly wired meter are satisfactory because they are equipped with vacuum thermocouples. When a Weston thermocouple is to be substituted for a vacuum thermocouple, tests as mentioned should be made to check the operation of the thermocouple-meter combination. If the trouble appears to be present, three methods of correction are available.

(1) Use a vacuum thermocouple if available; or

(2) Use a Hickok or Triplett meter if available; or

(3) Remove the Weston meter and unscrew and lift off the front portion of the case; open-circuit the connection between the scale plate and moving coil by clipping the strap which runs from the left screw and nut on the moving coil support and under the scale plate to the scale plate screw. Do not remove the nut on the moving coil support as that might cause the moving coil to become incorrectly positioned in its bearings and cause unsatisfactory operation of the meter.

(4) *Changes in Values.*

(a) Reduction in the Capacitance of C501, C502, C601, and C602.—C501 and C502 in the 12-volt dynamotor have been reduced from

0.003 to 0.002 microfarad. The same is true for C601 and C602 in the 24-volt dynamotor. Either value (0.002 or 0.003 microfarad) is satisfactory, however.

(b) Change in the Voltage Rating of the Postage-stamp Capacitors.—Some of the postage-stamp type of mica capacitors were changed to ones having a higher voltage rating. Capacitors having the voltage ratings shown in Paragraph 45, Table of Replaceable Parts, should be used for replacement purposes. Many capacitors of this type used in sets of early production did not show a designation as to voltage rating. More recently the voltage rating has been color coded, as shown in Paragraph 44. The sixth dot on the capacitor indicates the voltage rating—green for 500 volts, gray for 800 volts, and gold for 1000 volts.

(c) Change in Resistor R106.—R106 has been decreased from 1000 ohms to 100 ohms. The purpose was to keep the meter reading from going off scale when the battery voltage is high and switch D125 is in position 2. The resistor furnished in the spare parts has a resistance of 100 ohms. Replacement of a good existing 1000-ohm unit is not necessary unless the meter reading goes off scale when the battery voltage is high. Since this affects the meter reading you should allow for this when checking the operation of different transmitters.

(5) *Elimination and Addition of Parts.*

(a) Addition of R159.—R159 was added in later transmitters from the screen of the doubler V103 to ground, in order to make this tube operate more uniformly with wide variations of input voltage.

(b) Elimination of Capacitors C102 and C110.—C102, formerly connected to the filament of V101, and C110, formerly connected to the filament of V102, have been eliminated from the later transmitters. The purpose of this change was to reduce the use of mica capacitors. Either or both of these units may be omitted or removed without impairing the operation of the transmitter.

(c) Elimination of C160.—Capacitor C160 (across the primary of T102) has been

omitted from most transmitters. Some of these capacitors have failed due to surges occurring in the carbon microphone circuit. The omission of this unit in new equipment or removal of it from the existing equipment does not impair the performance of the transmitter. Its removal may cause a slight increase in response at the higher audio frequencies.

(d) Elimination of C107.—This capacitor has been found unnecessary because the units with which it was associated can be held to close tolerances during manufacture.

(e) Elimination of C503 and C603.—These capacitors across the low-voltage end of the 12- and 24-volt dynamotors, respectively, can be eliminated without causing trouble.

d. Changes Affecting All Units. All units of Radio Sets SCR-608-A and SCR-628-A use fasteners to hold covers in place. Most of the units employ Dzus fasteners but a number employ a Shakeproof fastener. Spare Shakeproof fasteners should not be used as replacements on units that have Dzus fasteners and vice versa.

e. Relative Characteristics of Various Types of Capacitors and Resistors. It has been necessary to substitute other types of capacitors in some places where mica units were specified. This has been done where such substitutions do not interfere with satisfactory operation of the radio equipment. In many cases the replacing units differ from the original units in size or

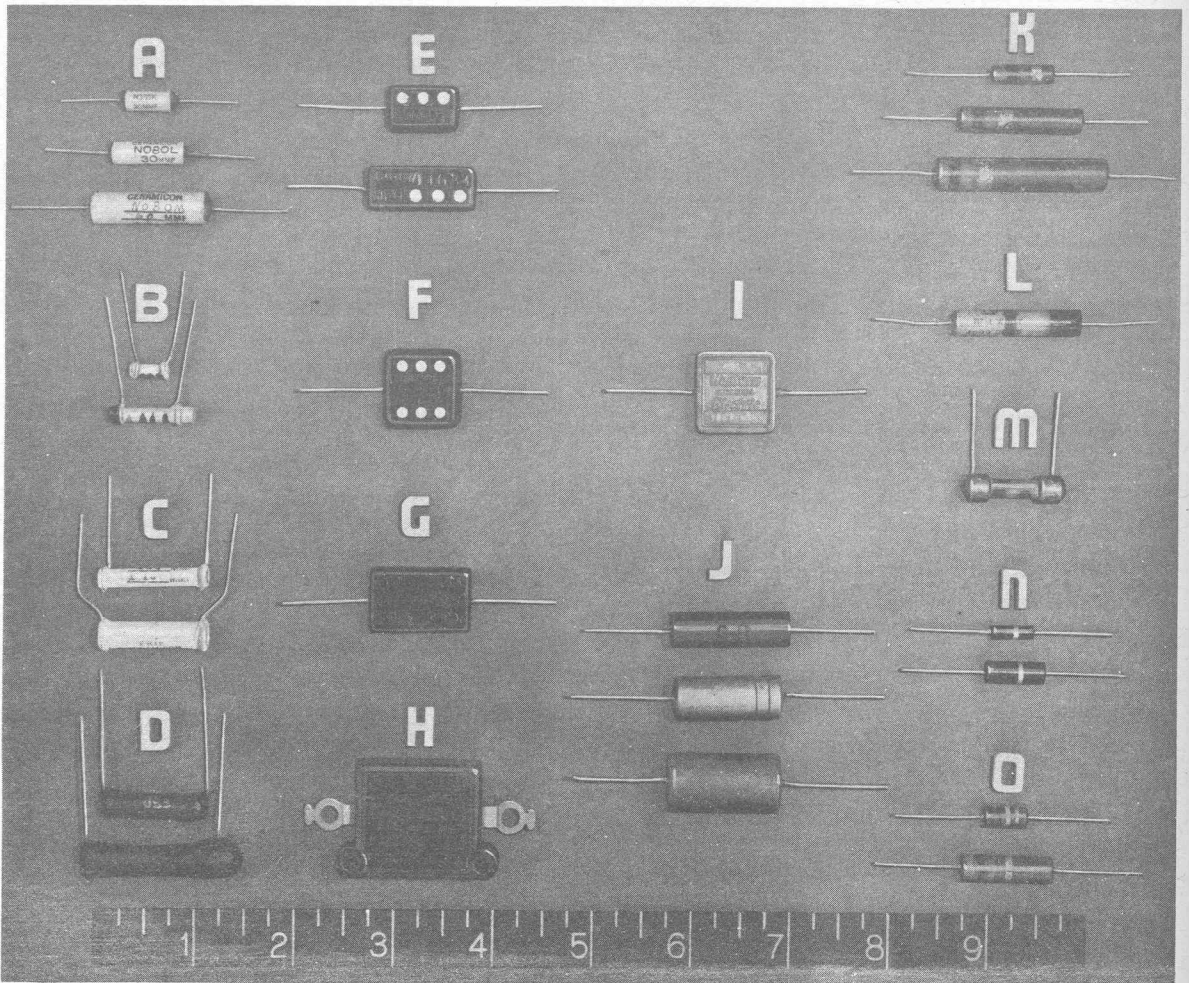

Fig. 63. Types of Capacitors and Resistors

shape or both. The relative appearance of the various capacitors and resistors used in these radio sets is shown in Fig. 63. The first column (A-D) shows ceramic capacitors. The second (E-H) shows mica capacitors and the third (I-J) shows oiled paper capacitors. In the fourth column (K-O) are various kinds of resistors. The general characteristics of such units are given in Table VII and discussed in more detail later. While Fig. 63 covers the range of types, it does not necessarily include all the variations produced by different manufacturers.

The units listed in Paragraph 45, Table of Replaceable Parts, have been selected because

they are the most suitable for the use for which they are specified. Other units, particularly ceramic capacitors, should not be used indiscriminately as replacements.

There are two general types of dielectric (insulation) which are often used in capacitors in place of mica. They are (1) ceramic material and (2) oiled paper. The ceramic capacitor consists of silver fired on ceramic insulation, the composition of the ceramic being varied to obtain different temperature coefficients. These are extremely stable and can be made to cover a wide range of values of temperature coefficients (from plus 120 to minus 750 parts per million

Table VII. Capacitor Characteristics

Group Letter (Fig. 63)	Type	Maximum as Used in This Equipment		Advantages	Disadvantages	Typical Use
		D-C Volts, Working Rating	$\mu\mu\text{f}$ Capacitance			
First Column						
A	Insulated Ceramicon (trade name)	800	200	Stability and choice of temperature compensation	Size limitation for large capacitance; also B, C, and D must not touch metal	Temperature compensation and replacement for small silver- mica units
B	Uninsulated ceramic	800	500			
C	Uninsulated Ceramicon	800	500			
D	Uninsulated ceramic	800	500			
*Second Column						
E (red)	Insulated silver-mica	800	700	Stability		Tuned circuits
E (brown)	Insulated mica	800	500	Ease of manu- facture		By-pass
F (red)	Insulated silver-mica	1000	1000	Stability		Tuned circuits
F (brown)	Insulated mica	1000	10,000	Ease of manu- facture		By-pass
G (brown)	Insulated mica	1000	10,000	Ease of manu- facture		By-pass
H (brown)	Insulated mica	1200	10,000	Ease of manu- facture		By-pass
*Third Column						
I	Insulated oiled paper	800	10,000	Does not require mica, a critical war material	Not suitable for tuned circuits or large r-f currents	By-pass, replacing F and G
J	oiled paper	800	10,000			

*These capacitors are not obtainable with controlled temperature coefficients.

per degree Centigrade.) For a given size of unit, the capacitance increases as the temperature coefficient becomes more negative. Therefore, no range of capacitance values can be assigned to a particular size without specifying the temperature coefficient. For a given temperature coefficient, the capacitance of a ceramic unit can be increased only by increasing the length or diameter of the tube.

The three sizes shown under group A (Fig. 63) cover the range of physical sizes in which these insulated ceramic capacitors are manufactured. These units were supplied originally in small sizes to provide temperature compensation for the combination of coil and mica capacitor in a tuned circuit. More recently, they have been specified in larger sizes in some tuned circuits to eliminate the need for a mica capacitor and provide temperature compensation for the coil. Since ceramic units with equal capacitance may differ greatly in temperature coefficient, it is not safe to use a ceramic unit for a replacement (where stability is needed) unless the temperature coefficient is known to be correct for that use.

The units illustrated under A and C have the value, tolerance, and temperature coefficient stamped on the unit. The black units shown under D are stamped with the capacitance and a letter signifying the temperature coefficient. Those shown under B are marked with dots in accordance with the color code described in Paragraph 44. Of all these ceramics, the A items are the only ones having adequate insulation to permit installing them where they might touch metal parts. Groups B and C are merely enameled. Group D has a black bakelite coating for moistureproofing but this is not sufficient insulation to permit contact with metal.

Five sizes of ceramic capacitors are shown in Fig. 63. The two smallest are those in B. The next two are those in C, and the largest is the lower unit in D. Except for insulation the largest unit in group A corresponds in characteristics to the small unit in group C.

It will be noticed that with uninsulated ceramic capacitors, the leads are sometimes at

unequal distances from the ends of the unit. The lead which is farther from the end is connected to the outer surface of the capacitor. Whenever possible, this lead should be connected to the ground, or low potential, side of the circuit.

In the conventional type of mica capacitor, strips of metal foil are interleaved between sheets of mica dielectric (insulation). Changes in temperature cause an undesirable amount of variation in the capacitance of such units. The silver-mica unit gives a much more stable capacitor which is suitable for tuned circuits. It consists of sheets of mica with electrodes of silver bonded to each surface.

Groups E and F illustrate the two types of color code discussed in Paragraph 44. Groups E, F, and G are made in both foil-mica and silver-mica units. Group H is used in the transmitter. It is a larger capacitor with higher voltage rating and has a more rigid mounting arrangement.

All the mica capacitors shown in the second column of Fig. 63 are insulated by a molded bakelite jacket and can be allowed to rest against metal. In general, the foil-mica units have a brown jacket, and the silver-mica units have a red jacket. Capacitors with a straw-colored bakelite jacket, as used in this equipment, may be either foil-mica, silver-mica, or paper units.

Ceramic capacitors are used where high stability is necessary and paper capacitors elsewhere whenever possible.

The capacitors shown in the third column of Fig. 63 use oil-impregnated paper for insulation. For stability, they do not compare with silver-mica types but they can be used as replacements for foil-mica types for screen grid and filament positions of vacuum tubes where they do not need to pass much radio-frequency current. In general, they are good substitutes for mica units for most by-pass purposes. The voltage rating decreases as the capacitance increases as follows:

Capacitance (microfarads)	0.003	0.006	0.01
Rating (d-c volts, working)	800	600	400

Group I shows a molded bakelite case which is adequate insulation. In general, such units will be black though they may be straw-colored.

Group J shows tubular-shaped units. The top unit has a thin bakelite cover and may be allowed to touch metal. The second unit in this group has a metal case and may have either one or both leads insulated from this case. If one lead is not insulated, it should be connected to ground or the lower voltage connection. The bottom unit in group J is identical with the second except for a cover which gives some insulating protection but is not sufficient to permit resting the unit against metal.

In summary, the unit specified in the Table of Replaceable Parts for a particular circuit symbol may be different in appearance from the one which it replaces and may require some ingenuity in mounting. Groups I and J are intended to take the place of F and G in some applications. Groups A, B, C, and D replace silver-mica units of groups E, F, and G where stability is required but must be used only as specified because of the wide range of temperature coefficients which they cover. As described in Paragraph 43b(10), sometimes a single ceramic unit is used to replace a silver-mica plus a small ceramic.

The fourth column (groups K-O) shows various small resistors. They vary considerably in size and shape for the same wattage ratings due to differences in manufacture. The units shown in group K are $\frac{1}{2}$ watt, 1 watt, and 2 watts, respectively. They are bakelite-insulated and may touch metal. The unit shown under L is a 1-watt unit. The unit shown at M with side leads is a high-frequency resistor. This has metal ends and is not insulated. This unit is used only in a few places in the transmitter. It is rated at $\frac{1}{2}$ watt. The units shown at group N (brown body) are bakelite-insulated resistors of the $\frac{1}{2}$ - and 1-watt sizes made by another manufacturer. (This manufacturer also makes a similar uninsulated resistor with a black body.) These are directly interchangeable with the upper two units in group K, above. The units shown at O are $\frac{1}{2}$ - and 1-watt sizes from still another manufacturer and are interchangeable with corresponding units already mentioned.

Similar units of other manufacture not shown may be used to replace those illustrated.

44. Color Codes on Components. The various types of capacitors and resistors used in Radio Sets SCR-608-A and SCR-628-A are illustrated in Fig. 63 and discussed in Paragraph 43e. Some capacitors and resistors have their values stamped on the unit, but in many cases colored dots and bands are used instead. The various color codes used for capacitors and resistors are shown in Figs. 64 to 68 inclusive, and are discussed in the following paragraphs.

a. Molded Mica Dielectric Capacitors. Capacitors of this type are illustrated in groups E, F, G, and H of Fig. 63. Three different color codes are used on these units:

The three-dot code.

The RMA (Radio Manufacturers Association) six-dot code.

The AWS (American War Standard) six-dot code.

(1) *Three-dot Code for Molded Mica Capacitors.* This code, which was widely used for a number of years, is gradually being replaced by the other two codes. However, many components so marked are used in Radio Sets SCR-608-A and SCR-628-A. Also, this code is likely to be encountered in parts stocks. As indicated in Fig. 64, the basis of the code is a series of three colored dots which indicate the capacitance, in micromicrofarads, of the unit. Two auxiliary colored dots indicating, respectively, the voltage rating and the capacitance tolerance, are sometimes, but not always, added. There is usually a molded or stamped arrow to show the sequence in which the dots are to be read. Dots one and two indicate the first two digits, while dot three tells the decimal multiplier to be used. Take, for example, a 0.006-microfarad capacitor. Its capacitance in micromicrofarads is 6000; the three dots, in sequence, are: blue (6), black (0), red (100).

The dot indicating the tolerance, when used, is usually located above or below the third (decimal multiplier) dot. As shown in Fig. 64, the various colors correspond to tolerances between plus or minus 1 per cent and plus or minus 20 per cent.

The voltage dot, when used, is ordinarily located above or below the first (first digit) dot. The various colors tell, according to the code of Fig. 64, the d-c working voltage.

When either or both of the auxiliary dots are omitted, it indicates that the capacitance tolerance is plus or minus 20 per cent and that the d-c working voltage is the lowest rating for the particular type and size of capacitor.

(2) *RMA Code for Molded Mica Capacitors.* The RMA (Radio Manufacturers Association) code illustrated in Fig. 65 is used to a limited extent. It uses six colored dots with an arrow to show the sequence. The first three dots give the first three digits of the capacitance in micromicrofarads; the fourth dot (directly below the third) gives the decimal multiplier. The fifth indicates the tolerance in capacitance, and

the sixth, the d-c working voltage. For example: a capacitor of 0.006 microfarad (6000 micromicrofarads) plus or minus 10 per cent, 800 volts d-c, working, would be marked with dots in the following order: blue (6); black (0); black (0); brown (multiplier 10); silver (plus or minus 10 per cent); gray (800 volts).

(3) *AWS Code for Molded Mica Capacitors.* The AWS (American War Standard) code for molded mica capacitors is shown in Fig. 66a. Like the RMA code, it uses six colored dots, but with somewhat different significance. The first four dots give the capacitance in micromicrofarads, as follows: first significant figure; second significant figure; third significant figure; decimal multiplier. It will be noted that this scheme makes provision for marking units in three significant figures. For example, consider a capaci-

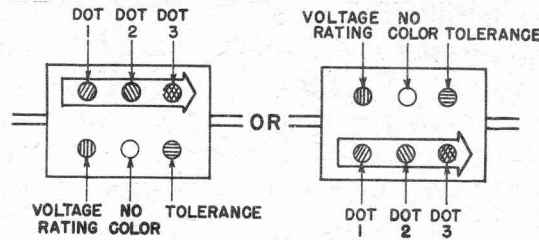

Color	First Dot	Second Dot	Third Dot	Tolerance	Voltage Rating
	First Digit	Second Digit	Decimal Multiplier		
Black	0	0	1	± 20%	
Brown	1	1	10	± 1%	100
Red	2	2	100	± 2%	200
Orange	3	3	1,000	± 3%	300
Yellow	4	4	10,000	± 4%	400
Green	5	5	100,000	± 5%	500
Blue	6	6	1,000,000	± 6%	600
Violet	7	7	10,000,000	± 7%	700
Gray	8	8	100,000,000	± 8%	800
White	9	9	1,000,000,000	± 9%	900
Gold	—	—	0.1	± 5%	1,000
Silver	—	—	0.01	± 10%	2,000
Body	—	—	—	± 20%	*

*When no color is indicated, the voltage rating may be as low as 300 volts.

Fig. 64. Molded Mica Capacitors: Three-dot Color Code

tor of 1,250 micromicrofarads. With the AWS code, the 1,250-micromicrofarad capacitor would be marked: brown (1), red (2), green (5), brown (10); the precise value of 1,250 micromicrofarads would thus be shown by the color code.

In practice, the precision markings just described are seldom necessary. In fact, none of the capacitors standardized under the AWS code requires more than two significant digits to specify its capacitance. For example, molded-mica-dielectric capacitors of the size known as "CM30" are standard in capacitances of 1000, 1100, 1200, 1300, 1500, 1600, etc., micromicrofarads. Intermediate values, such as 1,250 or 1,530, are not at present incorporated in the code. This is taken advantage of, as follows: The first dot on all capacitors now standard is black (0), and the two necessary significant figures are given by the second and third dots. The black first dot thus becomes a distinguishing feature or identification symbol, as it were, for a capacitor marked according to the AWS code. A couple of examples may serve to make this clear. Take, first, a 120-micromicrofarad capacitor; it is marked: black (0); brown (1); red (2); brown (10)—0120 micromicrofarads.

Or, consider a 9,100-micromicrofarad capacitor: black (0); white (9); brown (1); red (100)—09100 micromicrofarads. It will be noticed that in both these instances the first dot is black.

The fifth dot in the AWS code indicates the capacitance tolerance in per cent of nominal capacitance. The sixth dot indicates the design characteristics. The principal design characteristic, as indicated in Fig. 66a, is the temperature coefficient. For example a 0.006-microfarad (6000 micromicrofarads) plus or minus 10 per cent mica by-pass capacitor would be marked: black (0); blue (6); black (0); red (100); silver (plus or minus 10 per cent); black (mica by-pass, with no temperature coefficient specified).

It will be noted that this color code does not include the voltage rating. This is considered

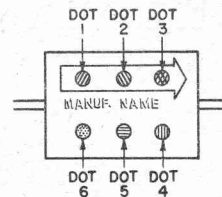

Color	First Dot First Digit	Second Dot Second Digit	Third Dot Third Digit	Fourth Dot Decimal Multiplier	Fifth Dot Tolerance	Sixth Dot Voltage
Black	0	0	0	1	—	—
Brown	1	1	1	10	1%	100
Red	2	2	2	100	2%	200
Orange	3	3	3	1,000	3%	300
Yellow	4	4	4	10,000	4%	400
Green	5	5	5	100,000	5%	500
Blue	6	6	6	1,000,000	6%	600
Violet	7	7	7	10,000,000	7%	700
Gray	8	8	8	100,000,000	8%	800
White	9	9	9	1,000,000,000	9%	900
Gold	—	—	—	0.1	5%	1,000
Silver	—	—	—	0.01	10%	2,000
Body	—	—	—	—	20%	500

Fig. 65. Molded Mica Capacitors: RMA Six-dot Color Code

unnecessary, since with few exceptions, all capacitors marked with this color code are rated at 500 d-c working volts. The exceptions, all of which are rated at 300 volts, are:

Type CM35 capacitors (53/64-inch maximum length) with capacitances of 6,800, 7,500, and 8,200 micromicrofarads.

Type CM40 capacitors (1-1/32 inch maximum length) with capacitances of 9,100 and 10,000 micromicrofarads.

Further details of the American War Standard for fixed-mica-dielectric capacitors will be found in Standard C75.3 of the American Standards Association.

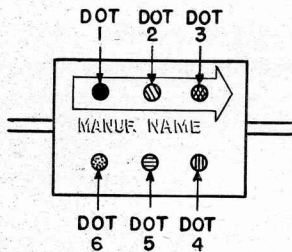

b. Molded Paper Dielectric Capacitors. A new AWS color code for small molded paper dielectric capacitors is shown in Fig. 66b. Although this code has found little application to date, it is possible that some units so marked may be encountered in future equipment or stocks. Like the code for mica capacitors just discussed, it employs six colored dots, together with an arrow to indicate the sequence. Units marked according to this system can readily be identified by the fact that both the first and fifth dots are always silver. The other dots are used as follows: the second dot gives the first digit of the capacitance in micromicrofarads; the third dot gives the second significant figure; the fourth dot indicates the decimal multiplier; the sixth tells whether the unit has a maximum operating temperature of 167 degrees or 185 degrees Fahrenheit.

No indication of the working voltage is given by the color code. In general, it can be said that molded paper dielectric capacitors meeting the AWS specification have d-c working voltages be-

Color	First Dot	Second Dot	Third Dot	Fourth Dot	Fifth Dot	*Sixth Dot
	First Digit	Second Digit	Third Digit	Decimal Multiplier	Tolerance	Characteristics
Black	0	0	0	1	± 20%	A
Brown	1	1	1	10	—	B
Red	2	2	2	100	± 2%	C
Orange	3	3	3	1,000	—	D
Yellow	4	4	4	—	—	E
Green	5	5	5	—	—	F
Blue	6	6	6	—	—	G
Violet	7	7	7	—	—	—
Gray	8	8	8	—	—	—
White	9	9	9	—	—	—
Gold	—	—	—	0.1	± 5%	—
Silver	—	—	—	0.01	± 10%	—

- *A. Ordinary mica by-pass.
- B. Same as A, low-loss case.
- C. By-pass or silver-mica capacitor (temperature coefficient: ± 200 parts/million/C).
- D. Silver-mica capacitor (temperature coefficient: ± 100 parts/million/C).
- E. Silver-mica capacitor (temperature coefficient: 0 to + 100 parts/million/C).
- F. Silver-mica capacitor (temperature coefficient: 0 to + 50 parts/million/C).
- G. Silver-mica capacitor (temperature coefficient: 0 to -50 parts/million/C).

Fig. 66a. Molded Mica Capacitors: AWS Six-dot Color Code

Color	First Dot	Second Dot	Third Dot	Fourth Dot	Fifth Dot	Sixth Dot
		First Digit	Second Digit	Decimal Multiplier		Characteristics
Black		0	0	1		*A
Brown		1	1	10		†B
Red	First dot silver to indicate AWS paper capacitor	2	2	100		—
Orange		3	3	1,000		—
Yellow		4	4	—		—
Green		5	5	—		—
Blue		6	6	—		—
Violet		7	7	—		—
Gray		8	8	—		—
White		9	9	—		—
Gold		—	—	—		—
Silver		—	—	—		—

*A. Operating temperature range, -67 to +185 F.
 †B. Operating temperature range, -67 to +167 F.

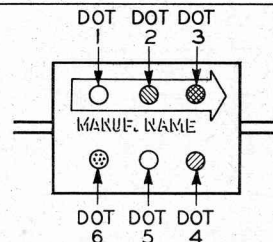
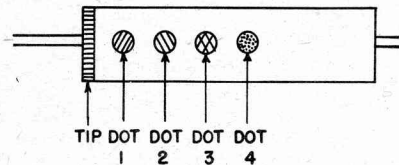

Fig. 66b. Molded Paper Capacitors: AWS Six-dot Color Code

Color	Tip	First Dot	Second Dot	Third Dot	Fourth Dot
	*Temperature Coefficient	First Digit	Second Digit	Decimal Multiplier	†Tolerance
Black	0	0	0	1	±20
Brown	0.00003 neg.	1	1	10	± 1
Red	0.00008 neg.	2	2	100	± 2
Orange	0.00015 neg.	3	3	1,000	± 3
Yellow	0.00022 neg.	4	4	10,000	± 4
Green	0.00033 neg.	5	5	100,000	± 5
Blue	0.00047 neg.	6	6	1,000,000	± 6
Violet	0.00075 neg.	7	7	0.001	± 7
Gray	—	8	8	0.01	± 2.5
White	—	9	9	0.1	±10

*The temperature coefficient is expressed in micromicrofarads per micromicrofarad per degree Centigrade. Some capacitors are marked with a numeral instead of a color code; for example, N-030 represents 0.00003 neg.
 †Tolerances for capacitors of 10 micromicrofarads or less are expressed in tenths of a micromicrofarad instead of percentages.

Fig. 67. Tubular Ceramic Capacitors: RMA Color Code

tween 300 and 800 volts. The lower voltage applies to units with high-capacitance ratings; the higher voltage applies to units with low-capacitance ratings. Further details will be found in Standard C75/221 of the American Standards Association.

c. Tubular Ceramic Dielectric Capacitors. Tubular ceramic dielectric capacitors, which are widely used for temperature compensation, are sometimes marked according to the RMA color code shown in Fig. 67. As will be seen from the figure, the negative temperature coefficient is in-

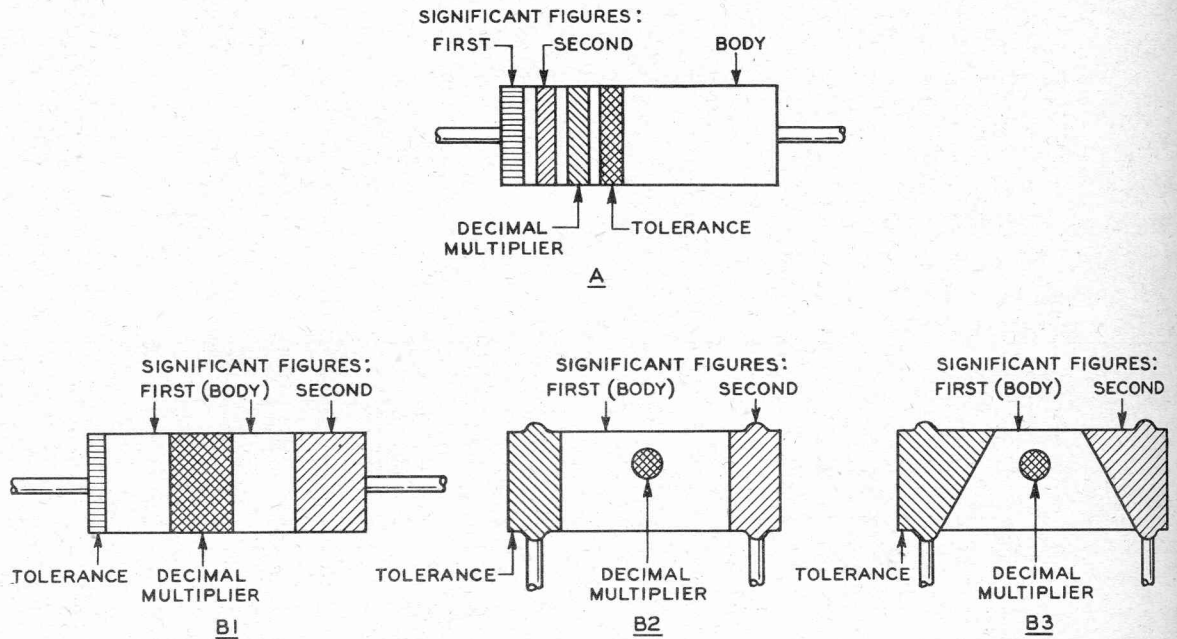

Color	First Significant Figure	Second Significant Figure	Decimal Multiplier	Tolerance
Black	0	0	1	—
Brown	1	1	10	± 1%
Red	2	2	100	± 2%
Orange	3	3	1,000	± 3%
Yellow	4	4	10,000	± 4%
Green	5	5	100,000	± 5%
Blue	6	6	1,000,000	± 6%
Violet	7	7	10,000,000	± 7%
Gray	8	8	100,000,000	± 8%
White	9	9	1,000,000,000	± 9%
Gold	—	—	0.1	± 5%
Silver	—	—	0.01	± 10%
No color	—	—	—	± 20%

Fig. 68. Fixed Resistors: RMA and AWS Standard Color Codes

indicated by the color of the band or tip at one end of the unit; the capacitance in micromicrofarads is shown by the first three dots; the capacitance tolerance, either in per cent or tenths of a micromicrofarad, depending upon the size of the unit, is indicated by the fourth and last dot. Example: a 30-micromicrofarad plus or minus 5-per-cent capacitor with a negative temperature coefficient of 80 parts per million per degree Centigrade would be marked as follows: tip, red (-80); first dot, orange (3); second dot, black (0); third dot, black (1); fourth dot, green (plus or minus 5 per cent).

d. Fixed Resistors. Small fixed resistors, both composition-type and wire-wound, are frequently marked with colored bands and dots to indicate the resistance and tolerance. Two color codes are widely used: the RMA and the AWS. The two codes are not identical in all particulars, but they are similar in many respects. One chart, applicable to both, is shown in Fig. 68. It will be seen that in all cases the various combinations of body color, bands, and dots indicate the resistance to two significant figures (the first two digits), the decimal multiplier, and the per cent tolerance in resistance.

As illustrated by Fig. 68, two basic methods are used for indicating the resistance and tolerance:

Method A. This uses four colored bands, starting at one end of the unit, to show resistance and tolerance. The bands, reading from left to right, indicate: first significant figure; second significant figure; decimal multiplier; per cent tolerance. (The significance of

the body color under this method will be explained later.)

Method B. Several variations of this method are in use (B1, B2, B3 of Fig. 68). With all of these, however, the interpretation of the code is practically the same: left end, tolerance; body, first significant figure; right end, second significant figure; central dot or band, decimal multiplier.

To illustrate the basic schemes, consider a 5,600-ohm \pm 10-per-cent fixed resistor. It would be marked:

Method A. First band, green (5); second band, blue (6); third band, red (100); fourth band, silver (\pm 10 per cent).

Method B. Left end, silver (\pm 10 per cent); body, green (5); right end, blue (6); central band or dot, red (100).

In Method A, where the body color plays no part in indicating resistance or tolerance, it may be used to indicate the type of resistor unit. Under the RMA code, a black body is frequently used to indicate an uninsulated composition unit; a tan, olive, or white body, an insulated composition unit; and a dark brown body, an insulated wire-wound unit. The AWS code requires that an uninsulated unit using Method A have a black body; the body of an insulated unit may be any color, although a natural tan is preferred.

When there is doubt as to whether a particular resistor is composition or wire-wound, it is well to remember that any resistor of 100 ohms or less is very likely to be wire-wound—also, to remember that it may be wound inductively.

45 TABLE OF REPLACEMENT PARTS (TABLE IX).

NOTE: The list of stock numbers is intended to supplement the Signal Corps General Catalog until such time as the catalog is revised to include the stock numbers in this table. Order re-
placement part by stock number and description.

Reference Number	Signal Corps Stock Number	Name and Description of Part	Function	Mfr.'s. Code and Type Number	Contractor's Drawing Number
a. Radio Receiver BC-683-A:					
	204460-683A	Radio Receiver BC-683-A		WE	
†C1.2, C1.4		Variable air capacitor, 62 µf, part of push-button tuner assembly	Tuning Control	WE	
†C1.6, C1.8		Trimmer capacitor, 16 µf, part of push-button tuner assembly	Trimming	WE	
†C1.1, C1.3		Capacitor, 0.006 µf, 300 volts dc	R-F Screen By-pass	C-D Type 1W	
†C1.5, C1.7	3DA6-10	Capacitor, 0.006 µf, 300 volts dc	Modulator Cathode By-pass	C-D Type 1W	
†C2	3DA6-10	Capacitor, 0.006 µf, 300 volts dc	Modulator Screen By-pass	C-D Type 1W	
†C3	3DA6-10	Capacitor, 0.006 µf, 300 volts dc	Beating Oscillator Plate Filter	C-D Type 1W	
†C4	3DA6-10	Capacitor, 0.006 µf, 300 volts dc	First I-F Screen By-pass	C-D Type 1W	
†C5	3DA6-10	Capacitor, 0.006 µf, 300 volts dc	Second I-F Screen By-pass	C-D Type 1W	
†C6	3DA6-10	Capacitor, 0.006 µf, 300 volts dc	Limiter Cathode By-pass	C-D Type 5W	
†C7	3DA6-10	Capacitor, 0.006 µf, 300 volts dc	Limiter Screen By-pass	C-D Type 1W	
†C8	3D9500-18	Capacitor, 500 µf, 500 volts dc	I-F Oscillator Coupling	Erie Type N680L	
†C9	3DA6-10	Capacitor, 0.006 µf, 300 volts dc	First Audio Grid Coupling	C-D Type 1W	
†C10	3D8975	Capacitor, 0.75 ± 0.25 µf, 500 volts dc	First Audio Grid Bias Filter	C-D Type 1D	
†C11	3DA6-10	Capacitor, 0.006 µf, 300 volts dc			
†C12	3DA10-48	Capacitor, 0.01 µf, 300 volts dc			

†Available in depot stock.
‡these capacitors are furnished as part of tuner assembly; see page 166.

†C13	3D9500-18	Capacitor, 500 µf, 500 volts dc	H-F Cutoff, First Audio Grid	C-D Type 5W	
†C14	3DA6-10	Capacitor, 0.006 µf, 300 volts dc	I-F AVC Filter	C-D Type 1W	
†C15	3DA500-30	Capacitor, 0.5 µf, 600 volts dc	AVC Filter	C-D Type DYR-6050	ESO-680334-2
†C16	3DB2.6020	Capacitor, 2 µf, 600 volts dc	Plate Supply Filter	C-D Type TLA-6020	ESO-680334-5
†C17	3DA10-48	Capacitor, 0.01 µf, 300 volts dc	Squelch Timing	C-D Type 1D	
†C18	3DA10-48	Capacitor, 0.01 µf, 300 volts dc	Squelch Timing	C-D Type 1D	
†C19	3DA2-16	Capacitor, 0.002 µf, 500 volts dc	H-F Cutoff, Second Audio Grid	C-D Type 1W	
†C20.1	3DA100-27	Capacitor (3 x 0.1 µf), 600 volts dc	Heater By-pass	C-D Type VC-932	ESO-680334-4
†C20.2			Squelching Voltage Filter		
†C20.3			First Audio Plate Filter		
†C21	3DA10-48	Capacitor, 0.01 µf, 300 volts dc	Second Audio Grid Coupling	C-D Type 1D	
†C22	3DA5-8	Capacitor, 0.005 µf, 300 volts dc	H-F Cutoff Second Audio Plate	C-D Type 1W	
†C23	3DB40-1	Special capacitor, 40 µf, 25 volts dc	Second Audio Cathode By-pass	C-D Per drawing	ESO-680334-1 ESO-680334-3
†C24	3DB1.6100A	Capacitor, 1 µf, 600 volts dc	Second Audio Screen By-pass	C-D Type DY-6100	
†C25	3DB2.88A	Capacitor, 2 µf, 600 volts dc	Plate Supply Filter	WE 288A	
C26	3DAL-13	Capacitor, 0.001 µf, 500 volts dc	I-F Oscillator Coupling	C-D Type 1W	
*†C26	3D9500-60	Capacitor, 0.0005 µf, 500 volts dc	I-F Oscillator Coupling	C-D Type 1W	
†R1	3Z4570	Resistor, 20,000 ohms ± 10%	R-F Screen Filter	IRC BT-1/2	
†R2	3Z4562	Resistor, 0.25 megohm ± 10%	Modulator Screen Filter	IRC BT-1/2	
†R3	3Z4524	Resistor, 500 ohms ± 10%	Modulator Cathode Bias	IRC BT-1/2	

†Available in depot stock.

*Modification during manufacture; see Paragraph 43.

Reference Number	Signal Corps Stock Number	Name and Description of Part	Function	Mfr.'s. Code and Type Number	Contractor's Drawing Number
a. Radio Receiver BC-683-A (continued).					
†R4	3Z4531	Resistor, 50,000 ohms ± 10%	Beating Oscillator Grid Leak	IRC BT-1/2	
†R5	3Z6500-8	Resistor, 5000 ohms ± 10%	Beating Oscillator Plate Filter	IRC BT-1	
†R6	3Z4550	Resistor, 0.1 megohm ± 10%	I-F Oscillator Coupling	IRC BT-1/2	
†R7	3Z6630-8	Resistor, 30,000 ohms ± 10%	First I-F Screen Filter	IRC BT-1	
R8	3Z6620-12	Resistor, 20,000 ohms ± 10%	Second I-F Screen Filter	IRC BT-2	
*†R8	3Z6670-1	Resistor, 70,000 ohms ± 10%	Second I-F Screen Filter	IRC BT-1/2	
†R9	3Z4525	Resistor, 1,000 ohms ± 10%	Limiter Screen Filter	IRC BT-1/2	
†R10	3Z4562	Resistor, 0.25 megohm ± 10%	First Audio Grid Coupling	IRC BT-1/2	
†R11	3Z4534	Resistor, 1 megohm ± 10%	First Audio Grid Leak	IRC BT-1/2	
†R12	3Z6200-17	Resistor, 2000 ohms ± 10%	First Audio Cathode Bias	IRC BT-1/2	
†R13	3Z4529	Resistor, 10,000 ohms ± 10%	AVC Filter	IRC BT-1/2	
†R14	3Z4562	Resistor, 0.25 megohm ± 10%	AVC Bias	IRC BT-1/2	
†R15	3Z4534	Resistor, 1 megohm ± 10%	Squelch Timing	IRC BT-1/2	
†R16	3Z4534	Resistor, 1 megohm ± 10%	Squelch Timing	IRC BT-1/2	
†R17	3Z4562	Resistor, 0.25 megohm ± 10%	Squelch Plate Load	IRC BT-1/2	
†R18	3Z4550	Resistor, 0.1 megohm ± 10%	First Audio Plate	IRC BT-1/2	
†R19	3Z4542	Resistor, 2 megohms ± 10%	Indicator Lamp Shunt	IRC BT-1/2	
†R20	3Z6030-11	Resistor, 300 ohms ± 10%	Second Audio Cathode Bias	IRC BW-1	

*Modification during manufacture; see Paragraph #3.
†Available in depot stock.

*†R21	3Z6630-7	Resistor, 30,000 ohms ± 10%	Voltage Divider Shunt	IRC BT-2
†R22	3Z4540	Resistor, 30,000 ohms ± 10%	Phone Series	IRC BT-1/2
†R23	3Z4528	Resistor, 5,000 ohms ± 10%	Second Audio Screen Filter	IRC BT-1/2
†R24	3Z6005-13	Resistor, 50 ohms ± 5%	Voltage Dividing Network	IRC BW-1/2
†R25	3Z6250-6	Resistor, 2,500 ohms ± 5%	Voltage Dividing Network	IRC BT-1/2
†R26	3Z6120	Resistor, 1,200 ohms ± 5%	Voltage Dividing Network	IRC BT-1/2
†R27	3Z6250-6	Resistor, 2,500 ohms ± 5%	Voltage Dividing Network	IRC BT-1/2
†R28	3Z6250-6	Resistor, 2,500 ohms ± 5%	Voltage Dividing Network	IRC BT-1/2
†R29	3Z6613	Resistor, 13,000 ohms ± 5%	Voltage Dividing Network	IRC BT-2
†R30	3Z4805	Resistor, 5 ohms ± 5%, 1 in.	Audio Output Dummy Load	W-L Type Z
†R31	3Z6568-1	Resistor, 6,800 ohms ± 5%	Voltage Dividing Network	IRC BT-1
†R32	3Z4540	Resistor, 30,000 ohms ± 10%	Phone Series	IRC BT-1/2
†R33	3Z4540	Resistor, 30,000 ohms ± 10%	Phone Series	IRC BT-1/2
†L1	2C4403A/C7	Choke (SC-1002)	Limitter Cathode Choke	W-E KS-8712
†FLLA	2C4460-683A/F1	Filter	First I-F Input	W-E Per drawing ESL-684082-3
C51	3D9100-19A	Capacitor, 100 µf ± 5%, 500 volts dc Part of FLLA	First I-F Grid Coupling	C-D Type 5R
C52	3DA1-22	Capacitor, 0.001 µf, 500 volts dc Part of FLLA	First I-F Grid Filter	C-D Type 1W
C53	3D9050-13	Capacitor, 50 µf ± 5%, 500 volts dc Part of FLLA	Modulator Plate Fixed Tuning	C-D Type 5R
C54	3D9010-5	Capacitor, 10 ± 1 µf, 500 volts dc Part of FLLA	Temperature Compensator for C53	Erie Type N680K ESL-684082-3

*Modification during manufacture; see Paragraph 43.

†Available in depot stock.

Reference Number	Signal Corps Stock Number	Name and Description of Part	Function	Mfr.'s. Code and Type Number	Contractor's Drawing Number
a. Radio Receiver BC-683-A (continued).					
C55	3D9010-5	Capacitor, 10 ± 1 μf, 500 volts dc Part of FL1A	Temperature Compensator for C56	Erie Type N680K	
C56	3D9050-13	Capacitor, 50 μf ± 5%, 500 volts dc Part of FL1A	First I-F Grid Fixed Tuning	C-D Type 5R	
C57	3DA6-10	Capacitor, 0.006 μf, 300 volts dc Part of FL1A	Modulator Plate Filter	C-D Type 1W	
R51	3Z4550	Resistor, 0.1 megohm ± 10% Part of FL1A	First I-F Grid Leak	IRC BT-1/2	
R52	3Z6643	Resistor, 43,000 ohms ± 10% Part of FL1A	First I-F Input Filter Termination	IRC BT-1/2	
R53	3Z4550	Resistor, 0.1 megohm ± 10% Part of FL1A	First I-F Grid Filter	IRC BT-1/2	
R54	3Z4550	Resistor, 0.1 megohm ± 10% Part of FL1A	Modulator Plate Filter	IRC BT-1/2	
R55	3Z4550	Resistor, 0.1 megohm ± 10% Part of FL1A	Modulator Plate Filter	IRC BT-1/2	
L51	2C4403A/C9	Coil Part of FL1A	First I-F Grid Tuned Coupling	WE Per drawing	ES0-680255-1
L52	2C4403A/C9	Coil Part of FL1A	Modulator Plate Tuned Coupling	WE Per drawing	ES0-680255-1
1FL2A	2C4460-683A/F2	Filter	Second I-F Input	WE Per drawing	ESL-684082-1
C61	3D9100-19A	Capacitor, 100 μf ± 5%, 500 volts dc Part of FL2A	Second I-F Grid Coupling	C-D Type 5R	
C62	3DA1-22	Capacitor, 0.001 μf, 500 volts dc Part of FL2A	Second I-F Grid Filter	C-D Type 1W	
C63	3D9050-13	Capacitor, 50 μf ± 5%, 500 volts dc Part of FL2A	First I-F Plate Fixed Tuning	C-D Type 5R	
C64	3D9010-5	Capacitor, 10 ± 1 μf, 500 volts dc Part of FL2A	Temperature Compensator for C63	Erie Type N680K	
C65	3D9010-5	Capacitor, 10 ± 1 μf, 500 volts dc Part of FL2A	Temperature Compensator for C66	Erie Type N680K	
C66	3D9050-13	Capacitor, 50 μf ± 5%, 500 volts dc Part of FL2A	Second I-F Grid Fixed Tuning	C-D Type 5R	

†Available in depot stock.

C67	3DA6-10	Capacitor, 0.006 μ f, 300 volts dc Part of FL2A	First I-F Plate Filter	C-D Type 1W	
R61	3Z4550	Resistor, 0.1 megohm \pm 10% Part of FL2A	Second I-F Grid Leak	IRC BT-1/2	
R62	3Z6643	Resistor, 43,000 ohms \pm 10% Part of FL2A	Second I-F Input Filter Termination	IRC BT-1/2	
R63	3Z4529	Resistor, 10,000 ohms \pm 10% Part of FL2A	Second I-F Grid Filter	IRC BT-1/2	
R64	3Z4525	Resistor, 1,000 ohms \pm 10% Part of FL2A	First I-F Plate Filter	IRC BT-1/2	
L61	2C4403A/C9	Coil Part of FL2A	Second I-F Grid Tuned Coupling	WE Per drawing	ESO-680255-1
L62	2C4403A/C9	Coil Part of FL2A	First I-F Plate Tuned Coupling	WE Per drawing	ESO-680255-1
†FL3A	2C4460-683A/F3	Filter	Limiter Input Filter	WE Per drawing	ESL-684082-2
*C71	3D9100-13	Capacitor, 50 μ f \pm 5% Part of FL3A	Limiter Input Filter	C-D Type 5R	ESL-684082-2
C71	3D9100-19A	Capacitor, 100 μ f \pm 5%, 500 volts dc Part of FL3A	Limiter Grid Coupling	C-D Type 5R	
C72	3DA1-22	Capacitor, 0.001 μ f, 500 volts dc Part of FL3A	Limiter Grid Filter	C-D Type 1W	
C73	3D9050-13	Capacitor, 50 μ f \pm 5%, 500 volts dc Part of FL3A	Second I-F Plate Fixed Tuning	C-D Type 5R	
C74	3D9010-5	Capacitor, 10 \pm 1 μ f, 500 volts dc Part of FL3A	Temperature Compensator for C73	Erie Type N680K	
C75	3D9010-5	Capacitor, 10 \pm 1 μ f, 500 volts dc Part of FL3A	Temperature Compensator for C76	Erie Type N680K	
C76	3D9050-13	Capacitor, 50 μ f \pm 5%, 500 volts dc Part of FL3A	Limiter Grid Fixed Tuning	C-D Type 5R	
C77	3DA6-10	Capacitor, 0.006 μ f, 300 volts dc Part of FL3A	Second I-F Plate Filter	C-D Type 1W	
R71	3Z4550	Resistor, 0.1 megohm \pm 10% Part of FL3A	Limiter Grid Leak	IRC BT-1/2	
*R71	3Z4562	Resistor, 250,000 ohms \pm 10% Part of FL3A	Limiter Grid Leak	IRC BT-1/2	
R72	3Z6643	Resistor, 43,000 ohms \pm 10% Part of FL3A	Limiter Input Filter Termination	IRC BT-1/2	

*Modification during manufacture; see Paragraph 43.

†Available in depot stock.

Reference Number	Signal Corps Stock Number	Name and Description of Part	Function	Mfr's. Code and Type Number	Contractor's Drawing Number
a. Radio Receiver BC-683-A (continued).					
*R72	3Z4540	Resistor, 30,000 ohms ± 10% Part of FL3A	Limiter Input Filter Termination	IRC BT-1/2	
R73	3Z4529	Resistor, 10,000 ohms ± 10% Part of FL3A	Limiter Grid Filter	IRC BT-1/2	
R74	3Z4529	Resistor, 10,000 ohms ± 10% Part of FL3A	Second I-F Plate Filter	IRC BT-1/2	
*R74	3Z4525	Resistor, 1,000 ohms ± 10% Part of FL3A	Second I-F Plate Filter	IRC BT-1/2	
L71	2C4403A/C9	Coil Part of FL3A	Limiter Grid Tuned Coupling	IRC Per drawing	ESO-680255-1
L72	2C4403A/C9	Coil Part of FL3A	Second I-F Plate Tuned Coupling	WE Per drawing	ESO-680255-1
†FL4	2C4403A/F4	Filter	Discriminator Filter Network	WE Per drawing	ESL-680250-1
C81	3D9250-9	Capacitor, 250 μf ± 10%, 500 volts dc Part of FL4	Detector R-F By-pass	C-D Type 5W	
C82	3DA6-10	Capacitor, 0.006 μf, 300 volts dc Part of FL4	Detector Cathode Filter	C-D Type 1W	
C83	3DA6-10	Capacitor, 0.006 μf, 300 volts dc Part of FL4	Limiter Plate Filter	C-D Type 1W	
C84	3D9005-13	Capacitor, 5 ± 0.5 μf, 500 volts dc Part of FL4	Temperature Compensation for Slope Circuit Secondary	Erie Type N680K	
C85	3D9050-13	Capacitor, 50 μf ± 2%, 500 volts dc Part of FL4	Half of Slope Circuit Secondary Tuning	C-D Type 5R	
C86	3D9050-13	Capacitor, 50 μf ± 2%, 500 volts dc Part of FL4	Half of Slope Circuit Secondary Tuning	C-D Type 5R	
C87	3D9025-4	Capacitor, 25 μf ± 5%, 500 volts dc Part of FL4	Limiter Plate Fixed Tuning	C-D Type 5R	
C88	3D9010-5	Capacitor, 10 ± 1 μf, 500 volts dc Part of FL4	Temperature Compensator for C87	Erie Type N680K	
R81	3Z6670-1	Resistor, 70,000 ohms ± 10% Part of FL4	Detector Load	IRC BT-1/2	
R82	3Z4562	Resistor, 0.25 megohm ± 10% Part of FL4	Detector Cathode Bias	IRC BT-1/2	

*Modification during manufacture; see Paragraph 43.
†Available in depot stock.

R83	3Z6670-1	Resistor, 70,000 ohms \pm 10% Part of FL4	Detector Load	IRC BT-1/2	
R84	3Z4562	Resistor, 0.25 megohm \pm 10% Part of FL4	Detector Cathode Bias	IRC BT-1/2	
R85	3Z4525	Resistor, 1,000 ohms \pm 10% Part of FL4	Limiter Plate Filter	IRC BT-1/2	
L81	2C4403A/C10	Coil Part of FL4	Detector Input Tuned Coupling	WE Per drawing	ES0-680254-1
L82	2C4403A/C9	Coil Part of FL4	Limiter Plate Tuned Coupling	WE Per drawing	ES0-680254-4
†LCU4	2C4460-683A/F4	Coupling Unit	Antenna Coupling	WE Per drawing	ESL-684080-1
C75	3DA6-10	Capacitor, 0.006 μ f, 300 volts dc Part of LCU4	R-F Grid Filter	C-D Type 1W	
R37	3Z4562	Resistor, 0.25 megohm \pm 10% Part of LCU4	R-F Grid Filter	IRC BT-1/2	
L32	2C4460-683A/C1	Coil Part of LCU4	Antenna Coupling	WE Per drawing	ES0-684085-5
†LCU2A	2C4460-683A/F5	Coupling unit	Modulator Input Tuning	WE Per drawing	ESL-684081-1
C36	3D9010-5	Capacitor, 10 \pm 1 μ f, 500 volts dc Part of LCU2A	R-F Plate Tuning and Compensation	Erie Type N680K	
C38	3D9005-13	Capacitor, 5 \pm 0.5 μ f, 500 volts dc Part of LCU2A	Modulator Grid Tuning and Compensation	Erie Type N680K	
C39	3DA6-10	Capacitor, 0.006 μ f, 300 volts dc Part of LCU2A	R-F Plate Filter	C-D Type 1W	
R38	3Z4525	Resistor, 1000 ohms \pm 10% Part of LCU2A	R-F Plate Filter	IRC BT-1/2	
L33	2C4460-683A/C2	Coil Part of LCU2A	R-F Plate Tuned Coupling	WE Per drawing	ES0-684083-1
L34	2C4460-683A/C2	Coil	Modulator Grid Tuned Coupling	WE Per drawing	ES0-684083-1
†LCU3A	2C4460-683A/F6	Tuned unit (unsealed)	R-F Oscillator Tuning Unit	WE Per drawing	ESL-684079-1
*†LCU3C	2C4460-683A/F6	Tuned unit (sealed)	R-F Oscillator Tuning Unit	WE Per drawing	ESL-694190-1
C41	3D9700	Capacitor, 700 μ f \pm 5%, 500 volts dc Part of LCU3A	Beating Oscillator Series Padder	C-D Type 2R	

†Available in depot stock.

Reference Number	Signal Corps Stock Number	Name and Description of Part	Function	Mfr.'s. Code and Type Number	Contractor's Drawing Number
a. Radio Receiver BC-683-A (continued).					
C42	3D9200-6	Capacitor, 200 ± 10 μmf, 500 volts dc Part of LCU3A	Temperature Compensator for C41	Erie Type N680M	
C43	3D9100-19A	Capacitor, 100 μmf ± 5%, 500 volts dc Part of LCU3A	Beating Oscillator Grid Blocking	C-D Type 5R	
*C44	—	Capacitor, 30 ± 1.5 μmf, 500 volts dc Part of LCU3A	Beating Oscillator Plate Coupling	Erie Type N150L	
C44	3D9030-3	Capacitor, 30 ± 1.5 μmf, 500 volts dc Part of LCU3A		Erie Type N080L	
*C44	—	Capacitor, 30 ± 1.5 μmf, 500 volts dc Part of LCU3A		Muter Type N200L	
C45	3D9100-19A	Capacitor, 100 μmf ± 5%, 500 volts dc Part of LCU3A	Oscillator-Modulator Coupling	C-D Type 5R	
C46	3D9020-1	Capacitor, 20 ± 1 μmf, 500 volts dc Part of LCU3A	Beating Oscillator Plate Temperature Compensator	Erie Type N680K	
R41	3Z4550	Resistor, 0.1 megohm ± 10% Part of LCU3A	Modulator Suppressor Grid Leak	IRC BT-1/2	ES0-684084-1
L41	2C4460-683A/C3	Coil Part of LCU3A	Beating Oscillator Tuning and Feedback	WE Per drawing	ESL-680247-1
1LCU4	2C4403A/21	Tuned unit	I-F Oscillator Tuning	WE Per drawing	
C91	3D9050-13	Capacitor, 50 μmf ± 5%, 500 volts dc Part of LCU4	I-F Oscillator Grid Coupling	C-D Type 5R	
C92	3D370	Capacitor, 50 ± 2 μmf, 500 volts dc Part of LCU4	I-F Oscillator Plate Shunt	Erie Type N680K	
C93	3D9100-19A	Capacitor, 100 μmf ± 5%, 500 volts dc Part of LCU4	I-F Oscillator Fixed Tuning	C-D Type 5R	
C94	3D9050-13	Capacitor, 50 μmf ± 5%, 500 volts dc Part of LCU4	I-F Oscillator Plate Coupling	C-D Type 5R	
R91	2Z4550	Resistor, 0.1 megohm ± 10% Part of LCU4	I-F Oscillator Grid Leak	IRC BT-1/2	
R92	3Z4549	Resistor, 40,000 ohms ± 10% Part of LCU4	I-F Oscillator Plate Load	IRC BT-1/2	
R93	3Z4549	Resistor, 40,000 ohms ± 10% Part of LCU4	I-F Oscillator Plate Load	IRC BT-1/2	

*Modification during manufacture; see Paragraph 43.
†Available in depot stock.

L91	2C4403A/G14	Coil Part of LOU4	I-F Oscillator Inductance	WE Per drawing	ES0-680254-2				
†D1	2C4403A/S2	Switch (SPST)	Power	H&H Per drawing	ES0-676800-6				
†D2	2C4403A/S2	Switch (SPST)	Headset	H&H Per drawing	ES0-676800-6				
†D3	2C4403A/S4	Switch (SPDT)	Loudspeaker	H&H Per drawing	ES0-676800-23				
†D4	2C4403A/S3	Switch (SPST and SPDT)	Squelch	H&H Per drawing	ES0-680937-1				
†D5	2C4403A/S2	Switch (SPST)	Tuning Oscillator	H&H Per drawing	ES0-676800-6				
†E1	2Z5893-1	Neon lamp	Indicator Lamp	GE Per drawing	ES0-680193-7				
†ES1	2Z5990-3	Socket, lamp-mounting	Socket for E1	Drake Per drawing	ES0-680506-1				
†F1	3Z1924	Fuse, 15 amperes	Power Supply	Littel Type 4AG					
†FML	3Z3282	Fuse holder	Fuse Holder	Littel No. 1212					
†FM2	3Z3282	Fuse holder	Spare	Littel No. 1212					
†J1	2C4403A/P3	Part of jack assembly	Headset	WE Per drawing	ES0-680358-1				
†J2	2C4403A/P3	Part of jack assembly	Headset	WE Per drawing	ES0-680358-1				
†J3	2C4403A/J2	Jack, socket assembly	Front Panel Socket Assembly	WE Per drawing	ES0-680358-3				
†LS1	6C35	Loudspeaker	Loudspeaker	Jensen Type PM 4FS Per drawing	ES0-678545-1				
†P1	2Z7298-1	Potentiometer, 100,000 ohms, taper C	Volume Control	IRC Type CS	ES0-680193-1				
†P2	2Z7299	Potentiometer, 200 ohms	Squelch Control	IRC Type W	ES0-680193-2				
†PG1	2C4403A/F1	Special plug	External Connections	Cannon Per drawing	ES0-677409-20				
†PG2	2Z7228	Plug	Dynamotor Plug	Jones Type P-318-AB					

†Available in depot stock.

Reference Number	Signal Corps Stock Number	Name and Description of Part	Function	Mfr's. Code and Type Number	Contractor's Drawing Number
a. Radio Receiver BC-683-A (continued).					
†PG3	2C4403A/P3	Plug, part of jack assembly	Front Panel Connections	WE Per drawing	ES0-680358-1
†T1	2C4403A/T3	Audio output transformer (SO-1005)	Audio Output	WE	KS-8714
†V1	2T112	Vacuum tube VT-112	R-F Amplifier	RCA (6AC7)	
†V2	2T112	Vacuum tube VT-112	Modulator	RCA (6AC7)	
†V3	2T94	Vacuum tube VT-94	Oscillator	RCA (6J5)	
†V4	2T209	Vacuum tube VT-209	I-F Amplifier	RCA (12SG7)	
†V5	2T209	Vacuum tube VT-209	I-F Amplifier	RCA (12SG7)	
†V6	2T112	Vacuum tube VT-112	Limiter	RCA (6AC7)	
†V7	2T90	Vacuum tube VT-90	Detector	RCA (6H6)	
†V8	2T107A	Vacuum tube VT-107-A	Second Audio Amplifier	RCA (6V6-GT)	
†V9	2T229	Vacuum tube VT-229	AVC and Squelch	RCA (6SL7-GT)	
†V10	2T229	Vacuum tube VT-229	First Audio and Oscillator	RCA (6SL7-GT)	
†VS1-VS10	2C4403A/S1	Socket	Socket	United Per drawings	ESL-678315-6 ESL-678315-10
†	2C4403A/S5.1	Push-button tuner assembly (includes Cl.1, Cl.2, Cl.3, Cl.4, Cl.5, Cl.6, Cl.7 and Cl.8)	Tuning	WE	KS-10099, List 2
†	2C6494/S6/2	Locking assembly, part of push-button tuner assembly, consisting of: Retainer yoke assembly	Tuning	WE	
		Cam			
		Yoke lock screw			ES0-684055-1
		Cam yoke			ES0-684056-2
		1/4-28 (NC3) hex. nut 3/8 in. across flats x 3/16 in. (steel-zinc plate)			ES0-684054-5
		1/4-28 (NC3) hex. nut 3/8 in. across flats x 3/32 in. (steel-zinc plate)			ES0-684056-1

†Available in depot stock.
‡Spare tubes furnished as separate item on contract.

Part Number	Description	Quantity	Unit	Notes
† 2C4403A/S5/1	Push button, part of push-button tuner assembly			
† 2C4403A/G1	Front panel guard			
† 2C4403A/B1	Binding post A			
† 2C4403A/B2	Binding post G			
† 2C4403A/B3	Bracket, hold-down			
† 2C4403A/W1	Shielded wire assembly			
† 2C4403A/W2	Shielded wire assembly			
† 2C4460-683A/K1	Knob			
† 2C4460-683A/C22	Dust cover			
† 2C6494A/F2	Shakeproof fastener			
† 2C4403A/P1/1	Special screw			
† 2C4403A/J3	Insulator			
† 2C4403A/H1	Handle			
† 2C4403A/W1	Mounting strip			
† 2S508/H1	Hardware for Radio Receiver BC-683-A			
† 2S508/1	Wire for Radio Receiver BC-683-A			
<u>b. Radio Transmitter BC-684-A.</u>				
† C101	Radio Transmitter BC-684-A			
† C103	3DA3-6 Capacitor, 0.003 µf, 800 volts dc			
	3D9100-21 Capacitor, 0.0001 µf ± 5%, 800 volts dc			
† Available in depot stock.				
	Tuning	WE	KS-10099 List 2	
	Front Panel Protection	WE Per drawing	ESO-678546-2	
	Antenna Connection	WE Per drawing	ESO-678764-16	
	Ground Connection	WE Per drawing	ESO-678764-20	
	Securing Receiver	WE Per drawing	ESO-680124-2	
	Antenna Jack Connections	WE Per drawing	ESO-680492-1	
	Antenna Post Connections	WE Per drawing	ESO-680492-2	
	Volume Control Knob	WE Per drawing	ESO-680382-3	
	Cover	WE Per drawing	ESR-678448-10	
	Securing Cover	Dzus		
	Mounting PGI	WE Per drawing	ESO-677334-11	
	Mounting Binding Posts A and G	WE Per drawing	ESO-680241-2	
	Front Panel	WE Per drawing	ESO-678672-1	
	Mounting Small Parts	WE Per drawing	{ ESO-688720-1 ESO-679393-1 ESO-680506-4	
	First R-F Screen By-pass	C-D Type IWPS		
	First R-F Plate Coupling	C-D Type IWPS		

Reference Number	Signal Corps Stock Number	Name and Description of Part	Function	Mfr.'s. Code and Type Number	Contractor's Drawing Number
†C104	3D9500-20	Capacitor, 0.0005 µf, 800 volts dc	Oscillator Plate By-pass	C-D Type 1WPS	
†C105	3D9015-2	Capacitor, 15 µf ± 10%, 500 volts dc	Oscillator Plate Tuning	WE Type N680K	
C106	See Note	Variable air capacitor, 350 µpf, Part of push-button tuner capacitor assembly	Rectifier Grid Tuning	WE	
†C108	3D9500-20	Capacitor, 0.0005 µf, 800 volts dc	Rectifier Grid Coupling	C-D Type 1WPS	
†C109	3DA3-6	Capacitor, 0.003 µf, 800 volts dc	Rectifier Screen By-pass	C-D Type 1WPS	
†C111	3DA3-6	Capacitor, 0.003 µf, 800 volts dc	Tripler Plate By-pass	C-D Type 1WPS	
†C112	3DA3-6	Capacitor, 0.003 µf, 800 volts dc	Doubler Grid By-pass	C-D Type 1WPS	
C113	See Note	Variable air capacitor, 60 µpf, Part of push-button tuner capacitor assembly	Tripler Plate Tuning	WE	
†C114	See Note	Variable air capacitor, 20 µpf, Part of push-button tuner capacitor assembly	Tripler Plate Trimmer	WE	
C115	See Note	Variable air capacitor, 60 µpf, Part of push-button tuner capacitor assembly	Doubler Grid Tuning	WE	
†C116	See Note	Variable air capacitor, 20 µpf, Part of push-button tuner capacitor assembly	Doubler Grid Trimmer	WE	
†C117	3DA3-6	Capacitor, 0.003 µf, 800 volts dc	Doubler Screen By-pass	C-D Type 1WPS	
†C118	3DA3-6	Capacitor, 0.003 µf, 800 volts dc	Doubler Plate By-pass	C-D Type 1WPS	
C119	See Note	Variable air capacitor, 80 µpf, Part of push-button tuner capacitor assembly	Doubler Plate Tuning	WE	
†C120	See Note	Variable air capacitor, 20 µpf, Part of push-button tuner capacitor assembly	Doubler Plate Trimmer	WE	

NOTE: Capacitors C106, C113, C115, C119, C152, C156, C114, C116, C120, C153, C157, C125-C136 inclusive, furnished as part of tuner assembly, page 177.
 †Available in depot stock.

†C121	3DA3-6	Capacitor, 0.003 µf, 800 volts dc	Doubler Plate Coupling	C-D Type 1WPS	
†C122	3DA3-6	Capacitor, 0.003 µf, 800 volts dc	Power Amplifier Screen By-pass	C-D Type 1WPS	
†C123	3DA10-48	Capacitor, 0.01 µf, 300 volts dc	Doubler Filament By-pass	C-D Type 1D	
†C124	3DA2-34	Capacitor, 0.002 µf, 1,200 volts dc	Power Amplifier Plate	C-D Type 4	
C125	See Note, page 168	Variable air capacitor, 60 µpf Part of push-button tuner assembly	Power Amplifier Tuning	WE	
C126	See Note, page 168	Variable air capacitor, 20 µpf Part of push-button tuner assembly	Power Amplifier Trimmer	WE	
C127 to C136 incl.	See Note, page 168	Variable air capacitor, 100 µpf Part of push-button tuner assembly	Antenna Tuning	WE	
†C137	3DA500-27	Capacitor, 0.5 µf, 600 volts dc	First Audio Grid By-pass	C-D Type DXRT-6050	ES0-680242-2
†C138.1 } C138.2 }	3DA100-28	Capacitor, 600 volts dc Two sections, each 0.1 µf	Carbon Microphone Coupling	C-D Type DXRT-6011	ES0-680242-3
†C139	3DA500-27	Capacitor, 0.5 µf, 600 volts dc	First Audio Screen By-pass	C-D Type DXRT-6050	
†C140	206494/06	Electrolytic capacitor, 30 µf 500 volts dc	Carbon Microphone Filter	Mallory Type FF	ES0-680242-6
†C141	3DA500-27	Capacitor, 0.5 µf, 600 volts dc	First Audio Plate Coupling	C-D Type DXRT-6050	ES0-680242-2
†C142.1 } C142.2 }	3DA100-28	Capacitor, 600 volts dc Two sections, each 0.1 µf	Second Audio Grid By-pass First Audio Plate By-pass	C-D Type DXRT-6011	ES0-680242-3
†C143	3DA500-27	Capacitor, 0.5 µf, 600 volts dc	Second Audio Screen By-pass	C-D Type DXRT-6050	
†C145	3DB2.21	Capacitor, 2 µf, 1,000 volts dc	Plate Supply Filter	C-D Type TLA 10020	
†C146	3DA3-6	Capacitor, 0.003 µf, 800 volts dc	Oscillator Screen By-pass	C-D Type 1WPS	
C147	3D9175	Capacitor, 175 µf ± 3%, 500 volts dc	First R-F Plate Padding	C-D Type 1R	
*†C147	3D9175-5	Capacitor, 175 µf ± 2%, 800 volts dc	First R-F Plate Padding	Muter Type N100	

*Modification during manufacture; see Paragraph 43.
†Available in depot stock.

Reference Number	Signal Corps Stock Number	Name and Description of Part	Function	Mfr.'s. Code and Type Number	Contractor's Drawing Number
b. Radio Transmitter BC-681-A (continued).					
†C148	3DA3-6	Capacitor, 0.003 pf, 800 volts dc	Power Amplifier Grid By-pass	C-D Type 1WPS	
†C149	3DA1-21	Capacitor, 0.001 pf, 1,200 volts dc	Power Amplifier Plate Coupling	C-D Type 4	
†C150	3DA1-72	Capacitor, 0.001 pf, 800 volts dc	Oscillator Plate Coupling	C-D Type 1WPS	
†C151	3D9050-53	Capacitor, 0.00005 pf ± 5%, 800 volts dc	Oscillator Grid	C-D Type 5RPS	
C152	See Note, page 168	Variable air capacitor, 60 puf Part of push-button tuner capacitor assembly	Rectifier Plate Tuning	WE	
†C153	See Note, page 168	Variable air capacitor, 20 puf Part of push-button tuner capacitor assembly	Rectifier Plate Trimmer	WE	
†C154	3DA3-6	Capacitor, 0.003 pf, 800 volts dc	Rectifier Plate By-pass	C-D Type 1WPS	
†C155	3DA3-6	Capacitor, 0.003 pf, 800 volts dc	Tripler Grid By-pass	C-D Type 1WPS	
C156	See Note, page 168	Variable air capacitor, 60 puf Part of push-button tuner capacitor assembly	Tripler Grid Tuning	WE	
†C157	See Note, page 168	Variable air capacitor, 20 puf Part of push-button tuner capacitor assembly	Tripler Grid Trimmer	WE	
†C158	3DA3-6	Capacitor, 0.003 pf, 800 volts dc	Tripler Screen By-pass	C-D Type 1WPS	
†C159	3DA10-48	Capacitor, 0.01 pf, 300 volts dc	Tripler Filament By-pass	C-D Type 1D	
†C161	3D9100-70	Capacitor, 0.0001 pf, 800 volts dc	Transmission Line Series	C-D Type 5WPS	
†C162	20649HA/05	Electrolytic capacitor, 4 pf, 50 volts dc	Dynamotor Relay Filter	C-D Type AVL	ES0-678687-5
*†C164	3DA3-6	Capacitor, 0.003 pf, 1,000 volts dc	Tripler Plate By-pass	C-D Type 1WPS	
†R101	3Z4550	Resistor, 100,000 ohms ± 10%	Oscillator Grid	IRC ET-1/2	

*Modification during manufacture; see Paragraph 43
†Available in depot stock.

Part No.	Value	Application	W-L Type
R102	3Z5410-2	Resistor, 2 in., 1,000 ohms ± 10%	High Voltage Reducing W-L Type T
*†R102	3Z5366A7	Resistor, 2 in., 667 ohms ± 10%	High Voltage Reducing W-L Type A
†R103	3Z6725-5	Resistor, 250,000 ohms ± 10%	IRC BT-1
†R104	3Z6670-1	Resistor, 70,000 ohms ± 10%	IRC BT-1/2
†R105	3Z4531	Resistor, 50,000 ohms ± 10%	IRC BT-1/2
*†R106	3Z6010-18	Resistor, 100 ohms ± 10%	IRC BW-1/2
R107	3Z4540	Resistor, 30,000 ohms ± 10%	IRC BT-1/2
*†R107	3Z6630-21	Resistor, 30,000 ohms ± 10%	A-B GB-1
†R108	3Z6003-13	Resistor, 30 ohms ± 5%	IRC BW-1/2
†R109	3Z6675-10	Resistor, 75,000 ohms ± 10%	IRC BT-2
†R110	3Z4525	Resistor, 1,000 ohms ± 10%	IRC BT-1/2
R111	3Z6615-14	Resistor, 15,000 ohms ± 10%	IRC BT-1
*†R111	3Z6630-8	Resistor, 30,000 ohms ± 10%	IRC BT-1
†R112	3Z6001-2	Resistor, 10 ohms ± 10%	IRC BW-1/2
†R113	3Z4801-1	Resistor, 1-3/4 in., 1.0 ohm ± 5%	W-L Type Z
†R114	3Z6630-7	Resistor, 30,000 ohms ± 10%	IRC BT-2
†R115	3Z4550	Resistor, 100,000 ohms ± 10%	IRC BT-1/2
†R116	3Z6630-7	Resistor, 30,000 ohms ± 10%	IRC BT-2
†R117	3Z4531	Resistor, 50,000 ohms ± 10%	IRC BT-1/2

*Modification during manufacture; see Paragraph 43.

†Available in depot stock.

Reference Number	Signal Corps Stock Number	Name and Description of Parts	Function	Mfr's. Code and Type Number	Contractor's Drawing Number
b. Radio Transmitter BC-684-A (continued).					
R118	3Z6670-7	Resistor, 30,000 ohms \pm 10%	Oscillator Plate	IRC BT-2	
*†R118	3Z6700-12	Resistor, 100,000 ohms \pm 10%	Oscillator Plate	IRC BT-2	
R119	3Z6120-1	Resistor, 1,200 ohms \pm 10%	Rectifier Plate	IRC F-1/2	
*†R119	3Z6120-8	Resistor, 1,200 ohms \pm 10%	Rectifier Plate	IRC BT-1/2	
†R120	3Z6020-9	Resistor, 200 ohms \pm 10%	Carbon Microphone Series	IRC EW-1	
†R121	3Z6010-18	Resistor, 100 ohms \pm 10%	Carbon Microphone Filter	IRC EW-1/2	
†R122	3Z6725-5	Resistor, 250,000 ohms \pm 10%	First Audio Screen	IRC BT-1	
†R123	3Z6610-11	Resistor, 10,000 ohms \pm 10%	First Audio Plate Filter	IRC BT-1	
†R124	3Z4529	Resistor, 10,000 ohms \pm 10%	Second Audio Grid Filter	IRC BT-1/2	
†R125	3Z4528	Resistor, 5,000 ohms \pm 10%	Second Audio Grid	IRC BT-1/2	
†R126	3Z6675-10	Resistor, 75,000 ohms \pm 10%	Second Audio Screen	IRC BT-2	
†R127	3Z4801-1	Resistor, 1-3/4 in., 1.0 ohm, \pm 5%	Filament	W-L Type Z	
†R128	3Z4529	Resistor, 10,000 ohms \pm 10%	Sidetone Fixed	IRC BT-1/2	
†R129	3Z5450.4	Resistor, 2 in., 5,000 ohms \pm 10%	Bias	W-L Type A	
†R130	3Z4900-1	Resistor, 1-3/4 in., 100 ohms \pm 10%	Bias	W-L Type Z	
†R131	3Z4812	Resistor, 2 in., 12 ohms \pm 5%	Filament Supply Series	W-L Type A	
†R132	3Z4812	Resistor, 2 in., 12 ohms \pm 5%	Filament Supply Series	W-L Type A	

*Modification during manufacture; see Paragraph 43.

†Available in depot stock.

†R133	3Z4880	Resistor, 1-3/4 in., 80 ohms ± 10%	Dynamotor Relay Series	W-L Type Z
†R134	3Z4540	Resistor, 30,000 ohms ± 10%	Plate Current Metering	IRC ET-1/2
†R135	3Z4830	Resistor, 1-3/4 in., 30 ohms ± 10%	Antenna and Disabling Relays Series	W-L Type Z
†R136	3Z4540	Resistor, 30,000 ohms ± 10%	First Audio Screen Shunt	IRC ET-1/2
†R137	3Z6010-8	Resistor, 100 ohms ± 10%	Meter Series	A-B EB-1/2
†R138	3Z4531	Resistor, 50,000 ohms ± 10%	Oscillator Screen	IRC ET-1/2
†R139	3Z4550	Resistor, 100,000 ohms ± 10%	First R-F Grid	IRC ET-1/2
†R140	3Z4812	Resistor, 2 in., 12 ohms ± 5%	Filament Supply Series	W-L Type A
†R141	3Z4812	Resistor, 2 in., 12 ohms ± 5%	Filament Supply Series	W-L Type A
†R142	3Z6718-1	Resistor, 180,000 ohms ± 10%	Rectifier Screen Shunt	IRC ET-1
†R143	3Z6010-18	Resistor, 100 ohms ± 10%	Tripler Grid Metering	IRC BW-1/2
†R144	3Z4550	Resistor, 100,000 ohms ± 10%	Tripler Grid Leak	IRC ET-1/2
†R145	3Z6650-7	Resistor, 50,000 ohms ± 10%	Tripler Screen	IRC ET-2
†R147	3Z5366A7	Resistor, 2 in., 667 ohms ± 10%	High Voltage Reducing	W-L Type A
†R149	3Z6005-9	Resistor, 50 ohms ± 10% with L117	Oscillator Grid Anti-Sing	IRC F-1/2 Per drawing
†R151	3Z4608	Resistor, 100,000 ohms ± 10%	First Audio Plate	IRC ET-1
†R153	3Z5998-1	Resistor, 8.3 ohms ± 10%	Heater for Crystal Oven	IRC MW-5
†R154	3Z5998-1	Resistor, 8.3 ohms ± 10%	Heater for Crystal Oven	IRC MW-5

ES0-680330-2

†Available in depot stock.

<u>Reference Number</u>	<u>Signal Corps Stock Number</u>	<u>Name and Description of Part</u>	<u>Function</u>	<u>Mfr's. Code and Type Number</u>	<u>Contractor's Drawing Number</u>
b. Radio Transmitter BC-684-A (continued).					
†R155	3Z4550	Resistor, 100,000 ohms ± 10%	Antenna Static Leak	IRC BT-1/2	
†R156	3Z6003-4	Resistor, 30 ohms ± 10%	A-F Load	IRC BW-1	
†R157	3Z6030-5	Resistor, 300 ohms ± 10%	Tripler Plate Filter	IRC BW-1	
*†R157	3Z6030-11	Resistor, 300 ohms ± 10%	Tripler Plate Filter	IRC BW-1	
†R158	3Z6005-9	Resistor, 50 ohms ± 10% with L122	Power Amplifier Grid Anti-Sing	IRC F-1/2 Per drawing	ESO-680330-2
†R159	3Z4608	Resistor, 100,000 ohms ± 10%	Doubler Screen Shunt	IRC BT-1	
†R160	3Z5366A7	Resistor, 2 in., 667 ohms ± 10%	High Voltage Reducing	W-L Type A	
†R161	3Z6630-8	Resistor, 30,000 ohms ± 10%	Amplifier Grid	IRC BT-1	
†R162	3Z6700-12	Resistor, 100,000 ohms ± 10%	Oscillator Plate	IRC BT-2	
†R163	3Z6700-12	Resistor, 100,000 ohms ± 10%	Oscillator Plate	IRC BT-2	
†P101	2Z288-3	Potentiometer, 50,000 ohms	Sidestone Control	IRC Type CP Per drawing	ESO-680243-6
†L101	206494/C8	Coil, 3 millihenries, duolateral	First R-F Plate Choke	WE Per drawing	ESO-680243-3
†L102	206494/C9	Coil, 1 millihenry, duolateral	Oscillator Plate	WE Per drawing	ESO-680243-4
†L103A	206530-684A/C10	Coil, 0.38 millihenry, duolateral	First R-F Plate Tuning	WE Per drawing	ESO-690077-2
†L104	206494/C11	Retardation coil (SC-1003)	Modulation	WE D-164820	
†L105A	206530-684A/C12	Coil, 0.38 millihenry, duolateral	Second Audio R-F Choke	WE Per drawing	ESO-690077-3

*Modification during manufacture; see Paragraph 43.
†Available in depot stock.

†LL06	206530-684A/C13	Coil, close-wound solenoid	Tripler Plate Tuning	WE Per drawing	ESO-684453-1
†LL07	206530-684A/C13	Coil, close-wound solenoid	Doubler Grid Tuning	WE Per drawing	ESO-684453-1
†LL08	206530-684A/C14	Coil, close-wound solenoid	Doubler Plate Tuning	WE Per drawing	ESO-684453-2
†LL10	206530-684A/C15	Coil, space-wound solenoid	Amplifier Output Tuning	WE Per drawing	ESO-684455-1
†LL11	206530-684A/C15	Coil, space-wound solenoid	Antenna Coupling	WE Per drawing	ESO-684455-1
†LL17	206494A/C16	Coil, wound on R149	Oscillator Grid Anti-Sing	WE Per drawing	ESO-680330-2
†LL18	206530-684A/C17	Coil, close-wound solenoid	Tripler Grid Tuning	WE Per drawing	ESO-684453-3
†LL19	206530-684A/C17	Coil, close-wound solenoid	Rectifier Plate Tuning	WE Per drawing	ESO-684453-3
†LL20	206530-684A/C1	Coil, Z1 choke	Power Amplifier Plate Choke	Ohmite	
†LL21	206530-684A/C1	Coil, Z1 choke	Power Amplifier Grid Choke	Ohmite	
†LL22	206494A/C16	Coil, wound on R158	Power Amplifier Grid Anti-Sing	WE Per drawing	ESO-680330-2
†TL01	206494A/T2	Audio input transformer (SI-1005)	Microphone Input	WE	KS-8715
†TL02	206494A/T3	Audio output transformer (SO-1006)	Audio Output	WE	KS-8716
†SL01	206494A/R2	Relay (coil resistance, 44 ohms ± 5%)	Antenna Switching	Allied Per drawing	ESO-681226-1
†SL02	206494A/R3	Relay (coil resistance, 77 ohms; min. 73 ohms, max. 84 ohms)	Dynamotor Starting	Allied Per drawing	ESO-680329-1
†SL03	206494A/R5	Relay (coil resistance, 90 ohms)	Receiver Disabling	Allied Per drawing	ESO-677080-3
†DL10 to DL10 incl.	—	Switch (SPST), part of push-button tuner assembly	Quartz Plate Selector		
†DL11 to DL20 incl.	—	Switch (SPST), part of push-button tuner assembly	Antenna Capacitor Selector		
†DL21	206494A/S3	Toggle switch (DPDT)	Panel Meter	H&H Per drawing	ESO-676800-10
†DL22	206494A/S3	Toggle switch (DPDT)	Receiver Tune	H&H Per drawing	ESO-676800-10
†DL24	206494A/S4	Toggle switch (DPST)	Power Supply	H&H Per drawing	ESO-676800-21
†DL25	206494A/S5	Switch, with slotted shaft 1/2 in. long	Circuit Test	Mallory Type 3226J	ESO-680330-3

† Available in depot stock.
‡ See tuner assembly, page 177.

Reference Number	Signal Corps Stock Number	Name and Description of Part	Function	Mfr's. Code and Type Number	Contractor's Drawing Number
b. Radio Transmitter BC-684-A (continued).					
†F101	3Z2595-3	Fuse, 1/2 ampere	High Voltage	Littel Type 4AG	
†FM101	3Z3282	Fuse post	Fuse Holder	Littel Catalog No. 1212	
†FM102	3Z3282	Fuse post	Spare Fuse Holder	Littel Catalog No. 1212	
†J101	2C6494A/R1	Jack, 4-contact connector	Dynamic Microphone	Amphenol Per drawing	ESO-680353-3
†J102	2Z5575	Jack, with nickel-plated sleeve	Carbon Microphone	WE 249B	
†PG103	2C6494A/P2	Plug, 1/16, eight-contact plug	Dynamotor Plug	Jones P-408-AB	
†PG104	2C6949A/P2	Plug, 1/16, eight-contact plug	Dynamotor	Jones P-408-AB	
†E101	2Z5896	Lamp bulb, 28 volts, 0.17 ampere	Pilot Light	GE Mazda T 1-3/4 651 Base	ESO-680243-7
†ES101	2Z5990-2	Lamp mounting	Socket for Pilot Lamp	Drake Per drawing	ESO-680243-5
†M101	3F891-7	Meter	Tuning and Antenna Current	Weston Model No. 507 Per drawing	ESO-680241-1
†TC101	3F910-7/1	Thermocouple, 120 ma. radio frequency	Antenna Current	Weston Per drawing	ESO-680241-7
†TP101	2Z9183	Thermostat	Oven Control	Spencer Per drawing	ESO-680302-7
†PG101	2C6494A/P1	Plug	External Connections	Cannon Per drawing	ESO-677409-19
†V101	2T164	Vacuum tube, VT-164	First R-F Amplifier	RCA (1619)	
†V102	2T164	Vacuum tube, VT-164	R-F Rectifier	RCA (1619)	
†V103	2T164	Vacuum tube, VT-164	Doubler	RCA (1619)	

†Available in depot stock.

‡Spare tubes furnished as separate item on contact.

†V104	2T165	Vacuum tube, VT-165	Power Amplifier	RCA (1624)	
†V105	2T164	Vacuum tube, VT-164	First Audio Amplifier	RCA (1619)	
†V106	2T164	Vacuum tube, VT-164	Second Audio Amplifier	RCA (1619)	
†V107	2T164	Vacuum tube, VT-164	Oscillator	RCA (1619)	
†V108	2T164	Vacuum tube, VT-164	Tripler	RCA (1619)	
†VS101, VS102, VS103, VS105, VS106, VS107, and VS108	2C4403A/S1	Socket	Socket	United Per drawing	ESL-678315-3
†VS104	2Z8711	Socket, Isolantite, 5-prong	Socket	National Type CIR-5	
†	2C6494A/S6	Push-button tuner assembly (includes D101-D120 incl., C125, C126, C127-C136 incl., and capacitor assembly consisting of C106, C113, C115, C119, C152, C156, C114, C116, C120, C153, and C157)	Tuning	WE	KS-10098
†	2C6494/S/2	Locking assembly, part of push-button tuner assembly, consisting of:	Tuning	WE	
		Retainer yoke assembly			ES0-684055-1
		Cam			ES0-684056-2
		Yoke lock screw			ES0-684054-5
		Cam yoke			ES0-684056-1
		1/4-28 (NC3) hex. nut 3/8 in. across flats x 3/16 in. (steel-zinc plate)			
		1/4-28 (NC3) hex. nut 3/8 in. across flats x 3/32 in. (steel-zinc plate)			
†	2C4403A/S5/1	Push button, part of push-button tuner assembly	Tuning	WE	KS-10098
†	2C6494/G1	Front panel guard	Front Panel Protection	WE	ES0-678593-2
†	2C4403/B1	Binding post A	Antenna Connection	WE	ES0-678764-16
				Per drawing	

†Available in depo. stock.
‡Spare tubes furnished as separate item on contract.

Reference Number	Signal Corps Stock Number	Name and Description of Part	Function	Mfr's. Code and Type Number	Contractor's Drawing Number
†	206494B2	Binding post G	Ground Connection	WE Per drawing	ESO-678764-19
†	206494A9	Hold-down screw (incl. hold-down cup and spring)	Securing Radio Transmitter	WE Per drawing	ESO-678634-1
†	206494A13	Hold-down spacer	Securing Radio Transmitter	WE Per drawing	ESO-678634-5
†	206494A22	Cable assembly	Coaxial Cable from R101 to Binding Post A and S101	WE Per drawing	ESO-680502-2
†	206494A23	Cable assembly	Coaxial Cable from S101 to Binding Post A	WE Per drawing	ESO-680341-18
†	206494A11	Handle	Handle	WE Per drawing	ESO-678672-7
†	206530-6A/P3	Mounting plate	Resistor and Capacitor Mounting	WE Per drawing	ESO-688838-3
†	206530-6A/P4	Mounting plate	Mounting R114 and R116	WE Per drawing	ESO-690077-4
†	206530-6A/P5	Mounting plate	Mounting R112	WE Per drawing	ESO-686543-1
†	206494A/E5	Mounting plate	Mounting R110 and R143	WE Per drawing	ESO-680240-6
†	206494A/P7	Plate	Cover Plate (D111-D120 incl.)	WE Per drawing	ESO-680273-1
†	206494A/C24	Cover	Crystal Compartment Cover	WE Per drawing	ESO-680303-1
†	206494A/C25	Cover	Bottom Cover	WE Per drawing	ESO-680262-1
†	206530-684A/C1	Cover	Top Cover	WE Per drawing	ESO-679429-2
†	206494A/C27	Cover	Back Cover	WE Per drawing	ESO-680274-1
†	206494A/S10	Crystal socket strip	Sockets	WE Per drawing	ESO-680301-2
†	206494A/F1	Fastener	Crystal Drawer	Dzus	
†	206494A/F2	Fastener	Top, Bottom, and Back Cover	Dzus	

†	2C6494A/S11	Tube lock spacer assembly	Spacer	WE Per drawing	ESO-678634-8
†	2C6494A/C30	Tube clamp	Tube Clamp	WE Per drawing	ESO-680506-3
†	2C6530-684A/C29	Crystal drawer assembly	Crystal Storage	WE Per drawing	ESO-680270-1
†	2C6494A/P1/1	Mounting screw	Mounting PG101	WE Per drawing	ESO-680506-5
†	2C6494A/J2	Insulator	Crystal Socket Stud (short insulator)	WE Per drawing	ESO-606323-5
†	2C6494A/J3	Insulator	Crystal Socket Stud (long insulator)	WE Per drawing	ESO-606323-9
†	2C6494A/J4	Insulator	Antenna Binding Post	WE Per drawing	ESO-678721-6
†	2C6494A/J5	Insulator	Ground Binding Post	WE Per drawing	ESO-680241-2
†	2C6494A/C32	Cable clamp	Securing Cabled Wiring	Diamond No. 6	
†	2C6494A/C30	Clamp assembly	Tube Clamp Assembly	WE Per drawing	ESO-680506-3
†	2C6494A/C31	Plate connector	Plate of V104	WE Per drawing	ESO-681367-1
†	2C6494A/S12	Spring	Crystal Drawer	WE Per drawing	ESO-680263-1
†	2C6494A/B3	Brass plug button		United 48161	
†	2S508/H1	Hardware for Radio Transmitter BC-684-A			
†	2S508/1	Wire for Radio Transmitter BC-684-A			KS-8640
	c. Crystal Units.		Frequency Control	WE	ESO-680100

D-150249 crystal units
U.S. Signal Corps Holders FT-241-A,
for channels 270-389 in the 27.0 to
38.9-mc range

† Available in depot stock.

<u>Reference Number</u>	<u>Signal Corps Stock Number</u>	<u>Name and Description of Part</u>	<u>Function</u>	<u>Mfr.'s Code and Type Number</u>	<u>Contractor's Drawing Number</u>
d. <u>Mounting FT-237-(*)</u> .					
† C401	2Z6721-237D	Mounting FT-237-(*)			
	3D9100-20	Capacitor, 0.0001 µf, 500 volts dc	Radio Receiver Transmission-Line Compensator	C-D Type 5W	
† J401	2Z6721-237A/R1	Receptacle	Radio Receiver A Connection	Cannon Per drawing	ESO-677409-8
† J402	2Z6721-237A/R1	Receptacle	Radio Receiver B Connection	Cannon Per drawing	ESO-677409-8
† J403	2Z6721-237A/R2	Receptacle	Transmitter Connection	Cannon Per drawing	ESO-677409-7
† J404	2Z6721-237A/T2	Terminal	Transmitter Antenna	WE Per drawing	ESO-678764-17
† J405	2Z6721-237A/T1	Terminal	Radio Receiver Antenna	WE Per drawing	ESO-678764-18
†	2Z1480	Button	Cover for Unused Cable Openings	United No. 48157	
†	2Z8500	Vibro-insulator shock mounting	Shock Absorber	USR Per drawing	ESO-680179-1
† F401	3Z2166B	Fuse, 75 amperes	Battery Fuse	WE 66B	
† FW401	2Z6721-237A/P1	Fuse mounting (part of plate assembly) (incl. TS401)	Mounting Plate	WE Per drawing	ESO-680163-1
† TS401	2Z6721-237A/P1	Terminal strip (part of plate assembly) (incl. FW401)	Mounting Plate	WE Per drawing	ESO-680163-1
	2Z9014	Ground Strap	Flexible Grounding Strap	WE Per drawing	ESO-680165-3
†	2C6494A/J4	Insulator	Antenna Binding Post Bushings	WE Per drawing	ESO-678721-6
	6L4905-9.24Z	Mounting screw, 5/16-24x9/16 hex. head-iron cap mounting screw	Securing Mounting to Vehicle		
	6L4905-22.24Z	Mounting screw, 5/16-24x1-3/8 hex. head-iron cap mounting screw	Securing Mounting to Vehicle		
	6L3505-24	Mounting nut, 5/16-24 elastic stop mounting nut	Securing Mounting to Vehicle		

† Available in depot stock.

614905-12.24Z	5/16-24x3/4 hex. head-iron cap mounting screw	Securing Mounting to Vehicle	
6171005	5/16x9/64x5/64 steel nontangling spring lock washer	Securing Mounting to Vehicle	
2Z2600	Cable clamp	Cable Clamp	Zierick No. 79
3E2278	Signal Corps Cord CO-278 (8 feet long)	Battery Connections	ES0-680504-1
2Z6721-237A/C1	Cover	Covers for Unused Receptacles	WE Per drawing ES0-684051-1
2Z6721-237A/C5	Coaxial cable	Long Coaxial Cable	WE Per drawing ES0-680341-5
2Z6721-237A/C6	Coaxial cable	Short Coaxial Cable	WE Per drawing ES0-680341-6
2Z6721-237A/C2	Cover	Cover for Connector Assembly	WE Per drawing ES0-678721-5
2Z6721-237A/C11	Connector assembly	T-Shaped Connector	WE Per drawing ES0-678721-4
2Z6721-237A/C12	Connector assembly	L-Shaped Connector	WE Per drawing ES0-680341-10
2Z6721-237A/R3	Rear guide and fastener		WE
2Z6721-237A/F2	Front fastener		WE
2Z6721-237A/C7	Clamp	Dual Cable Clamp	WE Per drawing ES0-680164-4
2Z6721-237A/C8	Clamp	Interphone Cable	WE Per drawing ES0-680164-8
2Z6721-237A/C9	Clamp	Cabled Wiring Clamp	WE Per drawing ES0-680165-2
2Z6721-237A/C3	Cover	Rear Cover	WE Per drawing ES0-680159-1
2Z6721-237A/C4	Cover	End Cover	WE Per drawing ES0-680159-3A
2Z6721-237A/F1	Fastener	Door	Dzus

e. Remote Control Unit RM-29-D.

For the Table of Replaceable Parts for this unit, see Technical Manual TM 11-308.

† Available in depot stock.

Reference Number	Signal Corps Stock Number	Name and Description of Part	Function	Mfr's. Code and Type Number	Contractor's Drawing Number
f. Dynamotor DM-35-(*) (Transmitter; 12-Volt).					
†MG501	3H1635D	Dynamotor	High-Voltage Supply, with jack to Make 12-Volt Circuit Changes	WE Per drawing	KS-5581, List 1
C501	3D9300-2	Capacitor, 0.003 μf, 800 volts dc	R-F By-pass	C-D Type LWP	
*†C501	3DA3-7	Capacitor, 0.002 μf, 800 volts dc	R-F By-pass	C-D Type LWP	
C502	3D9300-2	Capacitor, 0.003 μf, 800 volts dc	R-F By-pass	C-D Type LWP	
*†C502	3DA3-7	Capacitor, 0.002 μf, 800 volts dc	R-F By-pass	C-D Type LWP	
†J501	3H1635A/R1	Receptacle	Dynamotor Connection and 12-Volt Circuit Changes	Jones SS-8-AB	Parts of KS-5581, List 1, Item 3
†J502	3H1635A/R1	Receptacle		Jones SS-8-AB	
†	3H1635A/B4	Low-voltage dynamotor brushes	Dynamotor Input	WE	KS-5581, List 1 Detail 4
†	3H1635A/B5	High-voltage dynamotor brushes	Dynamotor Output	WE	
†	3H1635A/A1	Dynamotor armature and bearings		WE	
†	3H1635A/B2	Dynamotor bearings		WE	
†	3H1635A/E27	End bell		WE Per drawing	
†	3H1635A/S1	Screw		WE Per drawing	
†	66670	Lubricant, 1/2-lb. can		WE Per drawing	
†	6Z4919	Rubber grommets		N.Y. & N.J. Type S-58	

*Modification during manufacture; see Paragraph 43.
 †Available in depot stock.
 ‡These parts formerly furnished as spares. Present spare parts list calls for complete dynamotor unit as a spare instead of these parts.

g. Dynamotor DM-37-(*) (Transmitter; 24-Volt) (not furnished on this order; listed for information only).

MG601	3H1637D	Dynamotor assembly	WE Per drawing	KS-5581, List 2
C601	3D9300-2	Capacitor, 0.003 μ f, 800 volts dc	C-D Type LWP	
*C601	3DA3-7	Capacitor, 0.002 μ f, 800 volts dc	C-D Type LWP	
C602	3D9300-2	Capacitor, 0.003 μ f, 800 volts dc	C-D Type LWP	
*C602	3DA3-7	Capacitor, 0.002 μ f, 800 volts dc	C-D Type LWP	
J601	3H1635A/R1	Receptacle	Jones SS-8-AB	
J602	3H1635A/R1	Receptacle	Jones SS-8-AB	
†	3H1637A/B4	Low-voltage dynamotor brushes	WE	Parts of KS-5581, List 2, Item 4
†	3H1635A/B5	High-voltage dynamotor brushes	WE	
†	3H1637A/A1	Dynamotor armature and bearings	WE	
†	3H1637A/B2	Dynamotor bearings	WE	
	3H1637A/B27	End bell	WE Per drawing	KS-5581, List 2, Detail 4
	3H1635A/S1	Screw	WE Per drawing	
	6G670	Lubricant, 1/2-lb. can	N.Y. & N.J. Type S-58	
	6Z4919	Rubber grommets		

h. Dynamotor DM-34-(*) (Receiver; 12-Volt).

†MG701	3H1634D	Dynamotor assembly	WE Per drawing	KS-5582, List 1
C701	3DA5-13	Capacitor, 0.005 μ f, 800 volts dc	C-D Type 3WP	

*Modification during manufacture; see Paragraph 43.

†Available in depot stock.

‡These parts were formerly furnished as spares. The present spare parts list calls for a complete dynamotor unit as a spare instead of these parts.

Reference Number	Signal Corps Stock Number	Name and Description of Part	Function	Mfr.'s. Code and Type Number	Contractor's Drawing Number
h. Dynamotor DM-34-(*) (Receiver; 12-Volt) (continued).					
*†C701	3DA3-24	Capacitor, 0.003 μ f, 1,000 volts dc	R-F By-pass	C-D Type 3WP	
C702	3DA5-13	Capacitor, 0.005 μ f, 800 volts dc	R-F By-pass	C-D Type 3WP	
*†C702	3DA3-24	Capacitor, 0.003 μ f, 1,000 volts dc	R-F By-pass	C-D Type 3WP	
C703	3DA5-13	Capacitor, 0.005 μ f, 800 volts dc	R-F By-pass	C-D Type 3WP	
*†C703	3DA3-23	Capacitor, 0.003 μ f, 500 volts dc	R-F By-pass	C-D Type 3W	
C704	3DA5-13	Capacitor, 0.005 μ f, 800 volts dc	R-F By-pass	C-D Type 3WP	
*†C704	3DA3-23	Capacitor, 0.003 μ f, 500 volts dc	R-F By-pass	C-D Type 3W	
C705	3DA5-13	Capacitor, 0.005 μ f, 800 volts dc	R-F By-pass	C-D Type 3WP	
*†C705	3DA3-24	Capacitor, 0.003 μ f, 1,000 volts dc	R-F By-pass	C-D Type 3WP	
C706	3DA5-13	Capacitor, 0.005 μ f, 800 volts dc	R-F By-pass	C-D Type 3WP	
*†C706	3DA3-24	Capacitor, 0.003 μ f, 1,000 volts dc	R-F By-pass	C-D Type 3WP	
†L701	2C4403A/C8	Choke coil (SC-1004)	High-Voltage Filter	WE	
†L702	3H1634A/C1	Coil	Low-Voltage Filter	WE Per drawing	ES0-680352-2
†L703	3H1634A/C2	Coil	High-Voltage Filter	WE Per drawing	ES0-680352-3
†L704	3H1634A/C2	Coil	Low-Voltage Filter	WE Per drawing	ES0-680352-3
†J701	3H1634A/R1	Receptacle	Dynamotor Connection and 12-Volt Circuit Changes	Jones S-318-AB	

Parts of
KS-5582, List 1,
Item 1, Fig. 2

KS-5582, List 1,
Detail 3

N.Y. & N.J.
Type S-58

Part No.	Description	Quantity	Notes	Reference
† 3H1634A/B4	Low-voltage dynamotor brushes			Dynamotor Input Dynamotor Output
† 3H1634A/B5	High-voltage dynamotor brushes			
† 3H1634A/A1	Dynamotor armature and bearings			
† 3H1634A/B2	Dynamotor bearings			
† 3H1634A/E27	End bell			
† 3H1634A/S1	Screw			
† 6G670	Lubricant, 1-1/2 lb. can			
1. <u>Dynamotor DM-36-(*) (Receiver; 24-Volt)</u> (not furnished on this order; listed for information only).				
MG801	Dynamotor assembly		High-Voltage Supply, with Jack to Make 24-Volt Circuit Changes	WE Per drawing KS-5582, List 2
C801	Capacitor, 0.005 µf, 800 volts dc		R-F By-pass	C-D Type 3WP
*C801	Capacitor, 0.003 µf, 1,000 volts dc		R-F By-pass	C-D Type 3WP
C802	Capacitor, 0.005 µf, 800 volts dc		R-F By-pass	C-D Type 3WP
*C802	Capacitor, 0.003 µf, 1,000 volts dc		R-F By-pass	C-D Type 3WP
C803	Capacitor, 0.005 µf, 800 volts dc		R-F By-pass	C-D Type 3WP
*C803	Capacitor, 0.003 µf, 500 volts dc		R-F By-pass	C-D Type 3W
C804	Capacitor, 0.005 µf, 800 volts dc		R-F By-pass	C-D Type 3WP
*C804	Capacitor, 0.003 µf, 500 volts dc		R-F By-pass	C-D Type 3W
C805	Capacitor, 0.005 µf, 800 volts dc		R-F By-pass	C-D Type 3WP
*C805	Capacitor, 0.003 µf, 1,000 volts dc		R-F By-pass	C-D Type 3WP

*Modification during manufacture; see Paragraph 43.
 †Available in depot stock.
 ‡These parts were formerly furnished as spares. The present spare parts list calls for a complete dynamotor unit as a spare instead of these parts.

Reference Number	Signal Corps Stock Number	Name and Description of Part	Function	Mfr's. Code and Type Number	Contractor's Drawing Number
1. Dynamotor DM-36-(*); (Receiver; 24-Volt) (continued).					
C806	3DA5-13	Capacitor, 0.005 µf, 800 volts dc	R-F By-pass	C-D Type 3WP	
*C806	3DA3-24	Capacitor, 0.003 µf, 1,000 volts dc	R-F By-pass	C-D Type 3WP	
L801	2C4403A/C8	Choke coil (SC-1004)	High-Voltage Filter	WE	ESO-680352-2
L802	3H1634A/C1	Coil	Low-Voltage Filter	WE Per drawing	
L803	3H1634A/C2	Coil	High-Voltage Filter	WE Per drawing	ESO-680342-3
L804	3H1634A/C2	Coil	Low-Voltage Filter	WE Per drawing	ESO-680352-3
J801	3H1634A/R1	Receptacle	Dynamotor Connection and 24-Volt Circuit Changes	Jones S-318-AB	
	3H1636A/B4	Low-voltage dynamotor brushes	Dynamotor Input	WE	
	3H1634A/B5	High-voltage dynamotor brushes	Dynamotor Output	WE	
†	3H1636A/A1	Dynamotor armature and bearings		WE	Parts of KS-5582, List 2, Item 2, Fig. 2
†	3H1636A/B2	Dynamotor bearings		WE	
†	3H1636A/E27	End bell		WE Per drawing	
	3H1634A/S1	Screw		WE	KS-5582, List 2, Detail 3
	60670	Lubricant, 1/2-lb. can		WE Per drawing	
				N.Y. & N.J. Type S-58	

*Modification during manufacture; see Paragraph 43.
 †These parts were formerly furnished as spares. The present spare parts list calls for a complete dynamotor unit as a spare instead of these parts.

j. List of Manufacturers (Table IX).

<u>Mfr's. Code</u>	<u>Name</u>	<u>Address</u>
A-B	Allen-Bradley Co.	136 West Greenfield Avenue, Milwaukee, Wis.
Allied	Allied Control Co.	227 Fulton Street, New York, N.Y.
Amphenol	American Phenolic Corporation	1250 Van Buren Street, Chicago, Ill.
Cannon	Cannon Electric Development Co.	420 West Avenue 33, Los Angeles, Calif.
C-D	Cornell-Dubilier Electric Corp.	South Plainfield, N.J.
Diamond	Diamond Expansion Bolt Co.	Garwood, N.J.
Drake	Drake Manufacturing Co.	1713 West Hubbard Street, Chicago, Ill.
Dzus	Dzus Fastener Co., Inc.	Babylon, N.Y.
Erie	Erie Resistor Corporation	Erie, Pa.
G.E.	General Electric Co.	Schenectady, N.Y.
H&H	Arrow-Hart & Hegeman Electric Co.	Hartford, Conn.
IRC	International Resistance Co.	403 North Broad Street, Philadelphia, Pa.
Isolanlite	Isolanlite, Incorporated	233 Broadway, New York, N.Y.
Jensen	Jensen Radio Manufacturing Co.	6601 South Laramie Avenue, Chicago, Ill.
Jones	Howard B. Jones	2300 Wabansia Avenue, Chicago, Ill.
Littel	Littelfuse, Inc.	4757 Ravenswood Avenue, Chicago, Ill.
Mallory	P. R. Mallory & Co., Inc.	Indianapolis, Ind.
Muter	Muter Company	1255 South Michigan Avenue, Chicago, Ill.
National	National Company	Malden, Mass.
N.Y. & N.J.	New York and New Jersey Lubricant Co.	300 Delancey Street, Newark, N.J.
Oak	Oak Manufacturing Co.	1260 Clybourn Avenue, Chicago, Ill.
Ohmite	Ohmite Manufacturing Co.	4837 Flournoy Street, Chicago, Ill.
RCA	RCA Manufacturing Co., Inc.	Harrison, N.J.
Spencer	Spencer Thermostat Co.	Attleboro, Mass.
United	United-Carr Fastener Corp.	Cambridge, Mass.
USR	United States Rubber Co.	191 Hudson Street, New York, N.Y.
WE	Western Electric Co., Inc.	120 Broadway, New York, N.Y.
W-L	Ward-Leonard Electric Corp.	32 South Street, Mount Vernon, N.Y.
Weston	Weston Electrical Instrument Corp.	618 Freylinghuysen Avenue, Newark, N.J.
Zierick	Zierick Manufacturing Co.	385 Gerard Avenue, New York, N.Y.

"6020 - Phila. - 45 - 02 - 7482 - Dec. - 44."

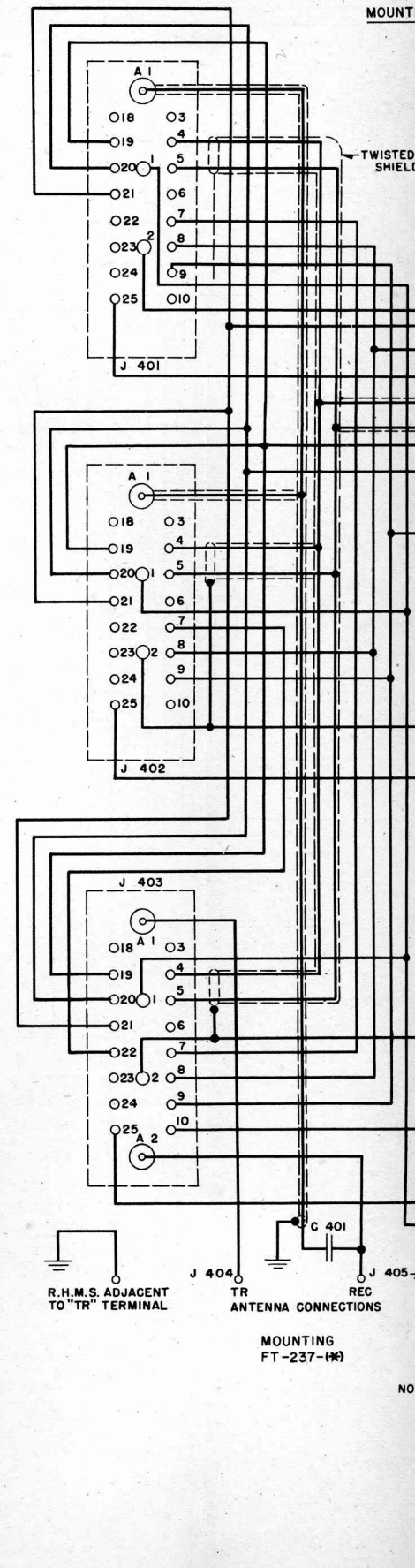
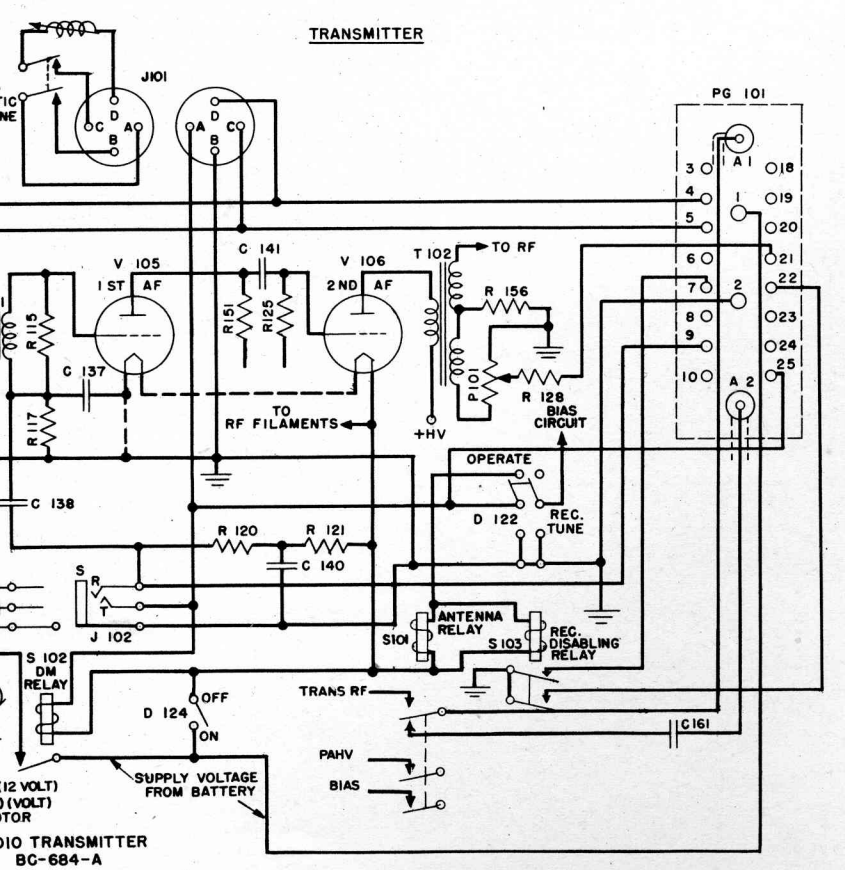
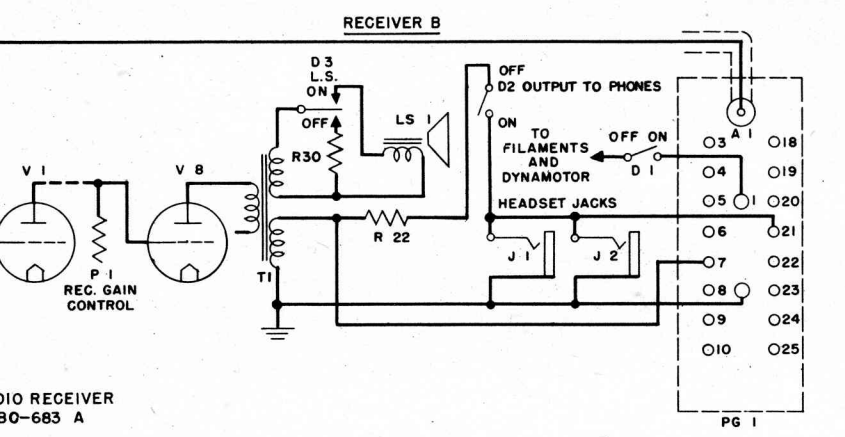
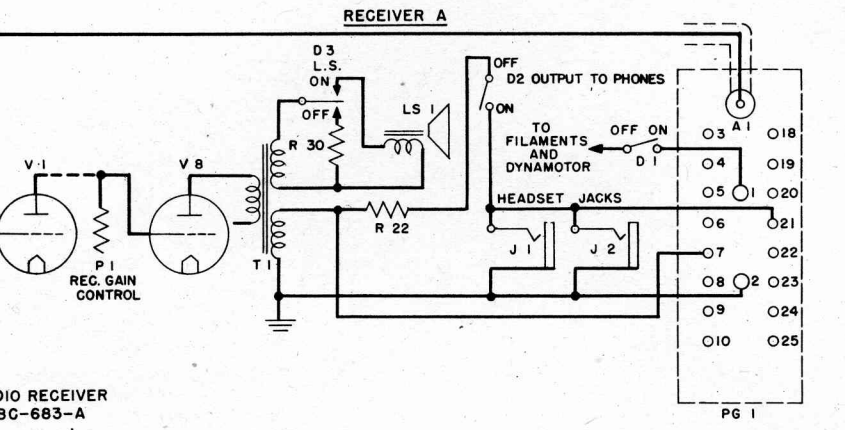
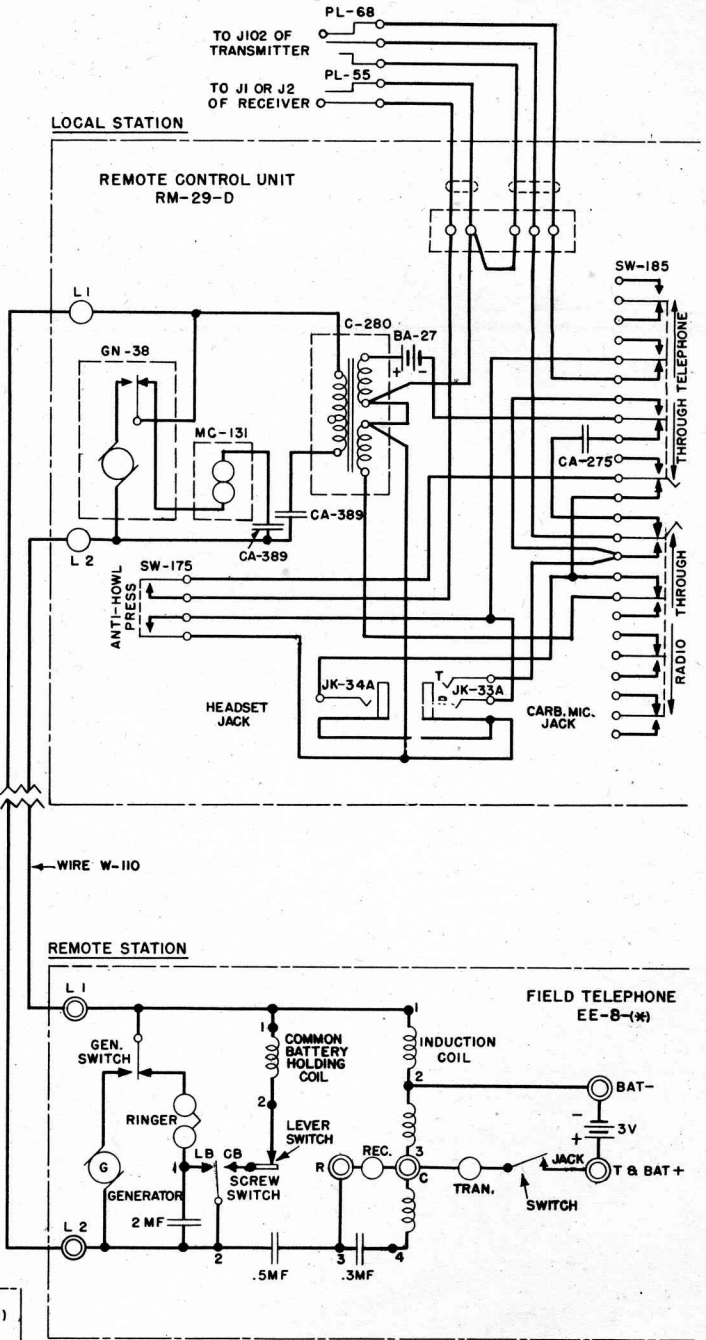
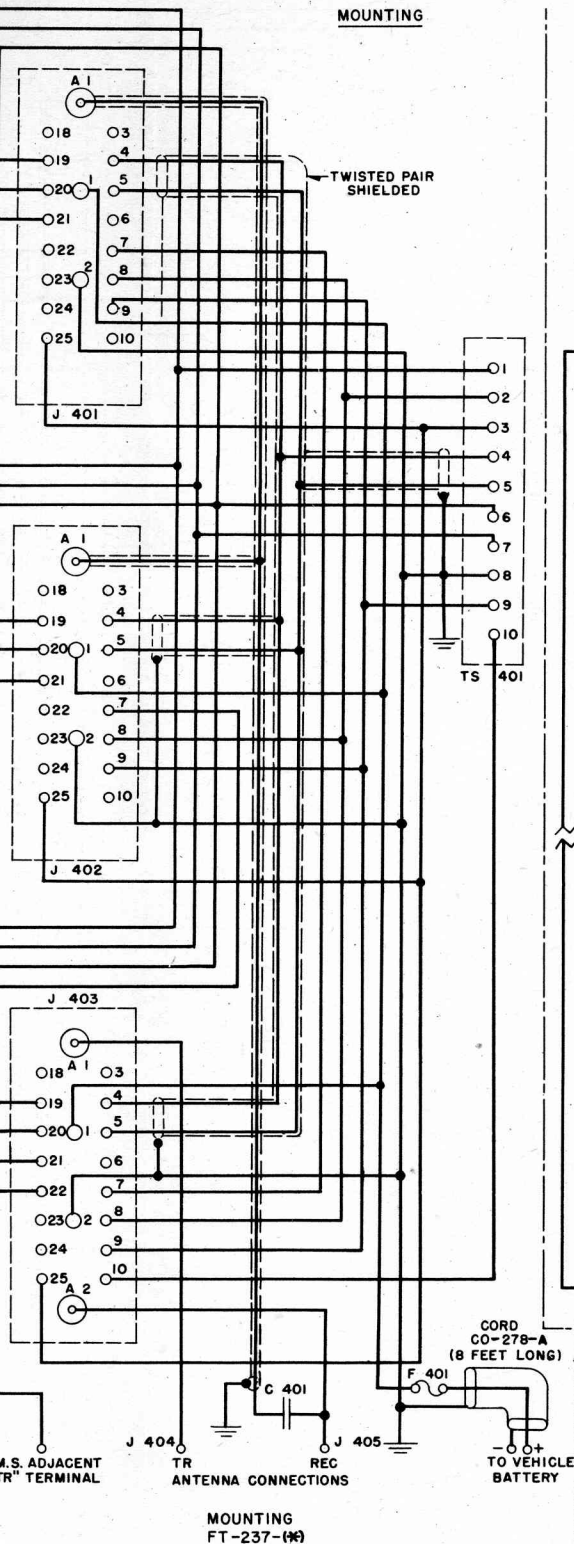
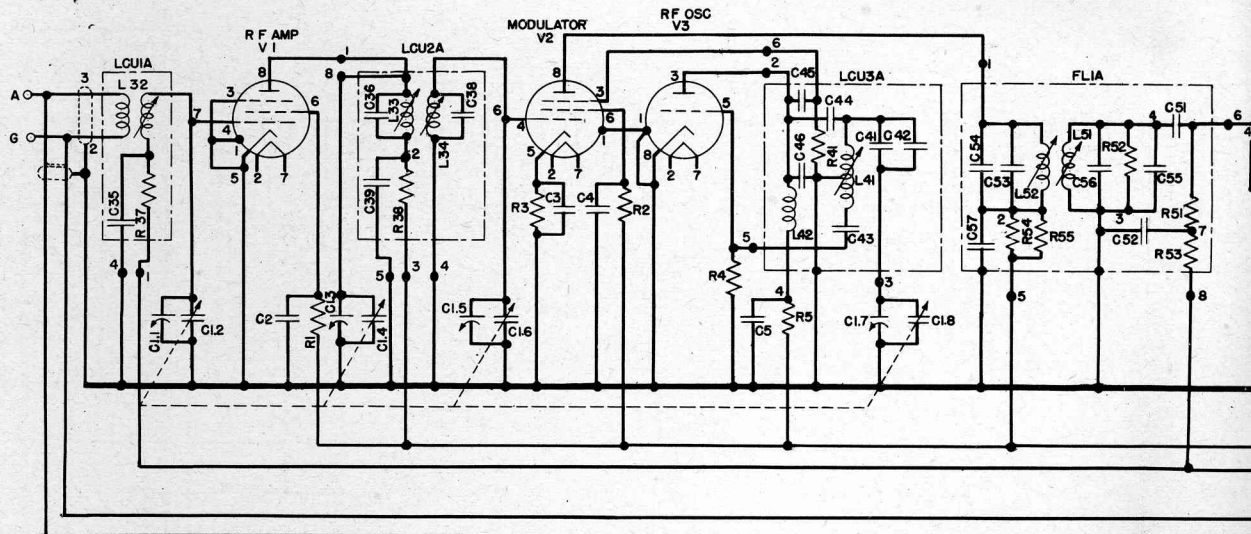

Fig. 69. Radio Set SCR-608-A: System Schematic Diagram



NOTES:
1. RADIO SET SCR-628-A TO BE SAME AS SHOWN EXCEPT ONLY ONE RADIO RECEIVER BC-683-A IS USED.



APPARATUS LEGEND

CAPACITORS				COILS		PLUGS	
SYMBOL	DESCRIPTION	SYMBOL	DESCRIPTION	SYMBOL	DESCRIPTION	SYMBOL	DESCRIPTION
C 11	16 UUF MAX	C 57	0.006 UF 300 V	C 804	-0.005 0.003 UF 800V	PG1	RECEIVER PLUG
C 13	16 UUF MAX	C 61	100 UUF 500 V	C 805	-0.005 0.003 UF 800V	PG2	DYNAMOTOR PLUG
C 15	16 UUF MAX	C 62	0.001 UF 500 V	C 806	-0.005 0.003 UF 800V	PG3	FRONT PANEL PLUG
C 17	16 UUF MAX	C 63	50 UUF	POTENTIOMETERS			
C 12	62 UUF MAX	C 64	10 UUF SEE NOTE 2	P 1	100,000 Ω		
C 14	62 UUF MAX	C 65	10 UUF	P 2	200 Ω		
C 16	62 UUF MAX	C 66	50 UUF SEE NOTE 2	RESISTORS			
C 18	62 UUF MAX	C 67	0.006 UF 300 V	R 1	20,000 Ω 1/2W		
C 2	0.006 UF 300 V	C 71	100 50 UUF 500V	R 2	250,000 Ω 1/2W		
C 3	0.006 UF 300 V	C 72	0.001 UF 500 V	R 3	500 Ω 1/2W		
C 4	0.006 UF 300 V	C 73	50 UUF 60 UUF 500 V	R 4	50,000 Ω 1/2W		
C 5	0.006 UF 300 V	C 74	10 UUF SEE NOTE 2	R 5	5,000 Ω 1/2W		
C 6	0.006 UF 300 V	C 75	10 UUF 60 UUF 500 V	R 6	100,000 Ω 1/2W		
C 7	0.006 UF 300 V	C 76	50 UUF SEE NOTE 2	R 7	30,000 Ω 1 W		
C 8	500 UUF 500 V	C 77	0.006 UF 300 V	R 8	40,000-70,000 Ω 1/2W		
C 9	0.006 UF 300 V	C 81	250 UUF 500 V	R 9	1,000 Ω 1/2W		
C 10	0.75 UUF 500 V	C 82	-0.01 0.006 UF 300 V	R 10	250,000 Ω 1/2W		
C 11	-0.01 0.006 UF 300V	C 83	0.006 UF 300 V	R 11	1,000,000 Ω 1/2W		
C 12	0.01 UF 300 V	C 84	5 UUF 500V SEE NOTE 1	R 12	2,000 Ω 1/2W		
C 13	500 UUF 500 V	C 85	50 UUF OR 60 UUF 500 V SEE	R 13	10,000 Ω 1/2W		
C 14	0.006 UF 300 V	C 86	50 UUF OR 60 UUF 500 V NOTE 2	R 14	250,000 Ω 1/2W		
C 15	0.5 UF 600 V	C 87	25 UUF	R 15	1,000,000 Ω 1/2W		
C 16	2 UF 600 V	C 88	10 UUF SEE NOTE 2	R 16	1,000,000 Ω 1/2W		
C 17	0.01 UF 300 V	C 91	50 UUF 500 V	R 17	100,000 Ω 1/2W		
C 18	0.01 UF 300 V	C 92	50 UUF 500 V	R 18	100,000 Ω 1/2W		
C 19	0.002 UF 500 V	C 93	100 UUF 500 V	R 19	100,000 Ω 1/2W		
C 20.1	0.1 UF 600 V	C 94	50 UUF 500 V	R 20	300 Ω 1 W		
C 20.2	0.1 UF 600 V	CAPACITORS DYNAMOTOR DM-34-(R) 12 V		R 21	30,000 Ω 2 W (ADDED)		
C 20.3	0.1 UF 600 V	C 701	-0.005 0.003 UF 800 V	R 22	30,000 Ω 1/2W		
C 21	0.01 UF 300 V	C 702	-0.005 0.003 UF 800 V	R 23	5,000 Ω 1/2W		
C 22	0.005 UF 300V	C 703	-0.005 0.003 UF 800 V	R 24	50 Ω 1/2W		
C 23	40 UF 25 V	C 704	-0.005 0.003 UF 800 V	R 25	2,500 Ω 1/2W		
C 24	1 UF 600 V	C 705	-0.005 0.003 UF 800 V	R 26	1,200 Ω 1/2W		
C 25	2 UF 600 V	C 706	-0.005 0.003 UF 800 V	R 27	2,500 Ω 1/2W		
C 26	-0.001 0.0005 UF 500V	CAPACITORS DYNAMOTOR DM-36-(R) 24 V		R 28	2,500 Ω 1/2W		
C 35	-0.01 0.006 UF 300V	C 801	-0.005 0.003 UF 800 V	R 29	13,000 Ω 2 W		
C 36	10 UUF 500 V	C 802	-0.005 0.003 UF 800 V	R 30	5 Ω 4 W		
C 38	5 UUF 500 V	C 803	-0.005 0.003 UF 800 V	R 31	6,800 Ω 1 W		
C 39	0.006 UF 300 V	C 804	-0.005 0.003 UF 800 V	R 32	30,000 Ω 1/2W		
C 41	700 UUF 500 V	C 805	-0.005 0.003 UF 800 V	R 33	30,000 Ω 1/2W		
C 42	200 UUF 500 V	C 806	-0.005 0.003 UF 800 V	R 37	250,000 Ω 1/2W		
C 43	100 UUF 500 V	JACKS		R 38	1,000 Ω 1/2W		
C 44	30 UUF 500 V	J 1	PHONES	R 41	100,000 Ω 1/2W		
C 45	100 UUF 500 V	J 2	PHONES	R 51	100,000 Ω 1/2W		
C 46	20 UUF 500 V	J 3	FRONT PANEL JACK	R 52	43,000 Ω 1/2W		
C 51	0.001 UF 500 V	J 701	DYNAMOTOR JACK	R 53	100,000 Ω 1/2W		
C 52	0.001 UF 500 V	J 801	DYNAMOTOR JACK				
C 53	50 UUF						
	OR 60 UUF 500V						
C 54	10 UUF SEE NOTE 2						
C 55	10 UUF						
	OR 60 UUF 500V						
C 56	50 UUF SEE NOTE 2						

Fig. 70.

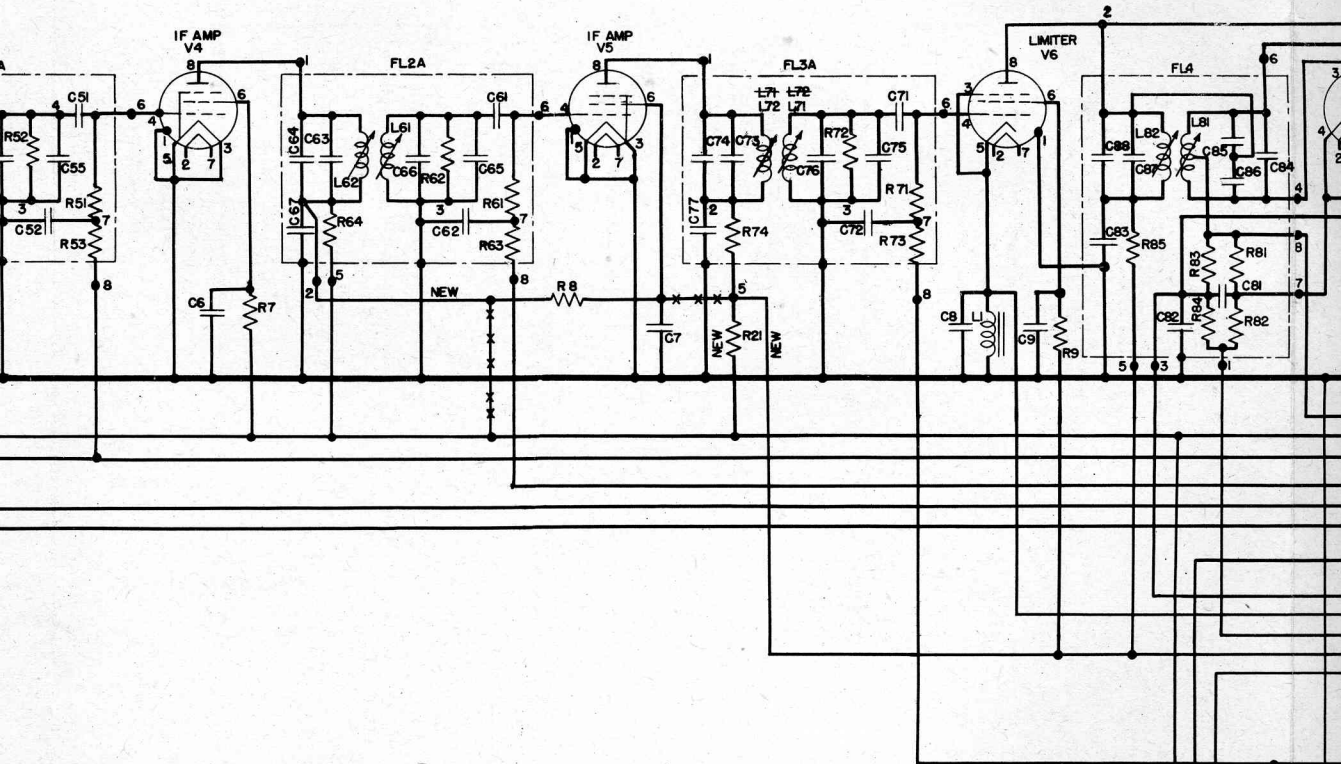

DESCRIPTION	SYMBOL	DESCRIPTION
RESISTORS		
RESISTOR PLUG	R 54	100,000 Ω 1/2 W
RESISTOR PLUG	R 55	100,000 Ω 1/2 W
PANEL PLUG	R 61	100,000 Ω 1/2 W
	R 62	43,000 Ω 1/2 W
	R 63	10,000 Ω 1/2 W
	R 64	1,000 Ω 1/2 W
	R 71	100,000 250,000 Ω 1/2 W
	R 72	43,000 30,000 Ω 1/2 W
	R 73	10,000 Ω 1/2 W
	R 74	100,000 1,000 Ω 1/2 W
	R 81	70,000 Ω 1/2 W
	R 82	250,000 Ω 1/2 W
	R 83	70,000 Ω 1/2 W
	R 84	250,000 Ω 1/2 W
	R 85	1,000 Ω 1/2 W
	R 91	100,000 Ω 1/2 W
	R 92	40,000 Ω 1/2 W
	R 93	40,000 Ω 1/2 W
SWITCHES		
	D 1	REC ON-OFF
	D 2	RADIO-B-EXT-EXT-ONLY- OUTPUT TO PHONES
	D 3	ON-OFF SPEAKER
	D 4	ON-OFF SQUELCH
	D 5	TUNE-OPERATE
VACUUM TUBES		
	V 1	VT-112 (6AC7)
	V 2	VT-112 (6AC7)
	V 3	VT-94 (6J5)
	V 4	VT-209 (12S67)
	V 5	VT-209 (12S67)
	V 6	VT-112 (6AC7)
	V 7	VT-90 (6H6)
	V 8	VT-107A (6V6GT)
	V 9	VT-229 (6SL7GT)
	V 10	VT-229 (6SL7GT)
MISCELLANEOUS		
	E 1	CALL SIGNAL (NEON)
	F 1	FUSE 15 AMP
	MG 701	12V DYNAMOTOR
	MG 801	24V DYNAMOTOR
	LS 1	LOUDSPEAKER
	T 1	OUTPUT TRANSFORMER

NOTES:

1. WHEN CAPACITORS C85 AND C86 ARE 60UUF, CAPACITOR C84 IS OMITTED.(OPTIONAL METHOD NOT SHOWN IN DIAGRAM.)
 2. TWO CAPACITORS REPLACED BY ONE HAVING A CAPACITY EQUAL TO THE TOTAL OF THE REPLACED TWO.(OPTIONAL METHOD NOT SHOWN IN DIAGRAM.)
- X ELIMINATED IN LATER UNITS.

PG 2

J 701



Fig. 70. Radio Receiver BC-683-A: Schematic Diagram Showing Modifications During Manufacture

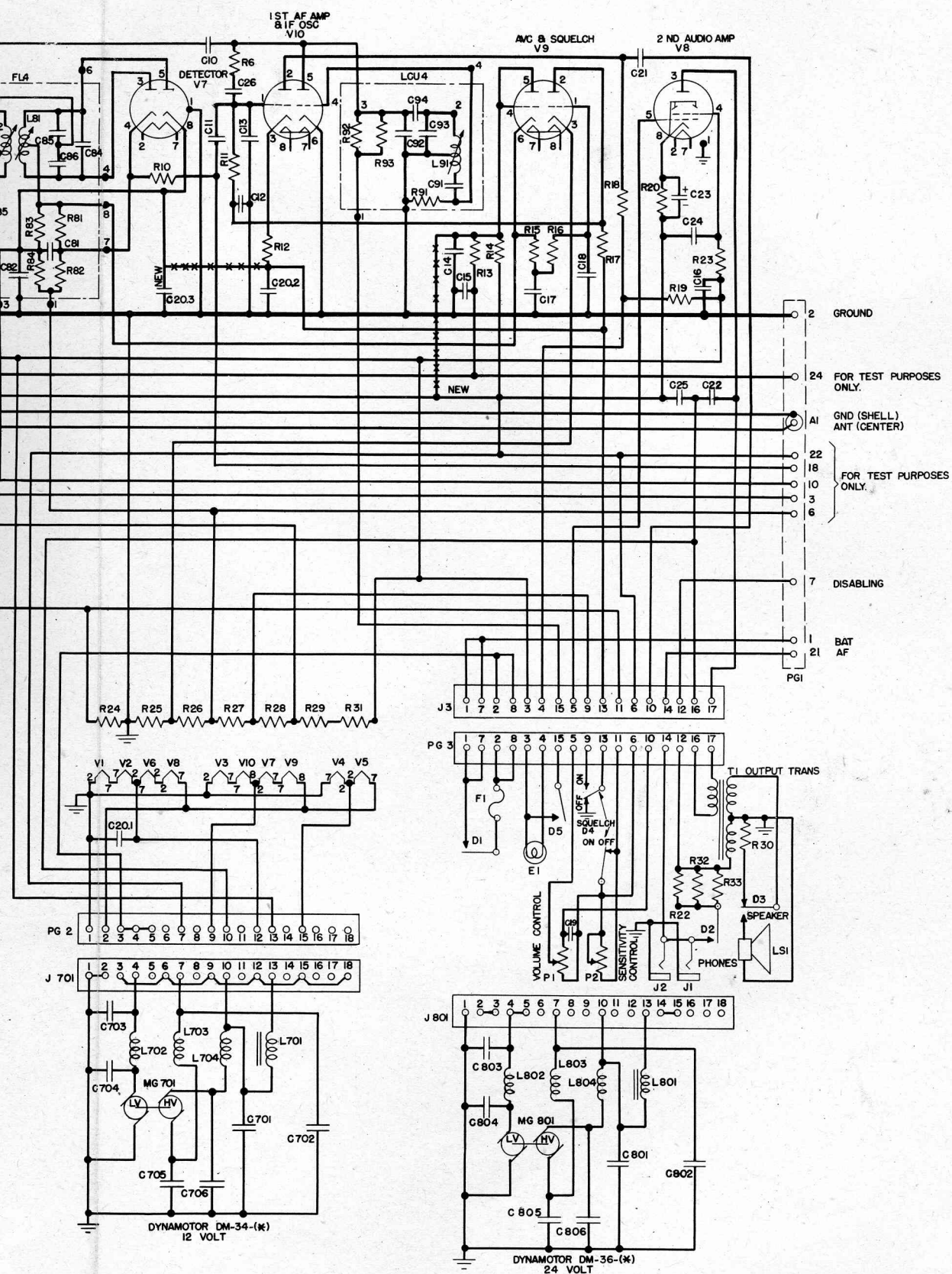

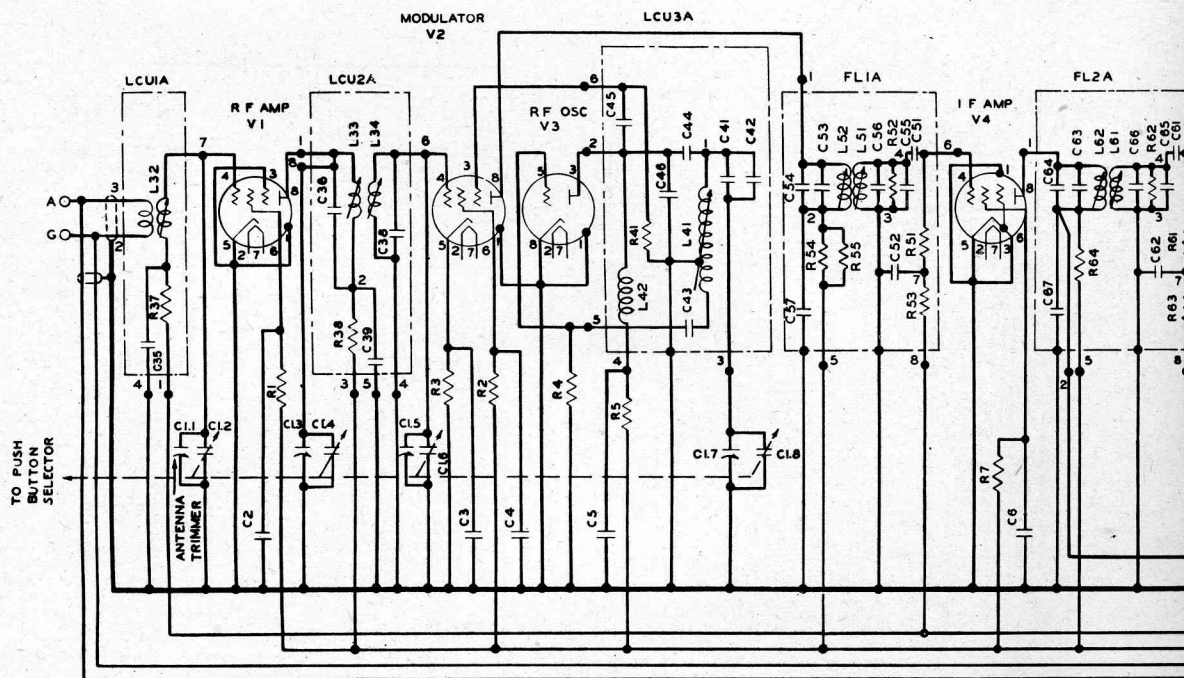

RADIO RECEIVER BC-683-A

CAPACITORS

- C1.1 16 UUF MAX
- C1.3 16 UUF MAX
- C1.5 16 UUF MAX
- C1.7 16 UUF MAX
- C1.2 62 UUF MAX
- C1.4 62 UUF MAX
- C1.6 62 UUF MAX
- C1.8 62 UUF MAX
- C2 0.006 UF 300 V
- C3 0.006 UF 300 V
- C4 0.006 UF 300 V
- C5 0.006 UF 300 V
- C6 0.006 UF 300 V
- C7 0.006 UF 300 V
- C8 500 UUF 500 V
- C9 0.006 UF 300 V
- C10 0.75 UUF 500 V
- C11 0.006 UF 300 V
- C12 0.01 UF 300 V
- C13 500 UUF 500 V
- C14 0.006 UF 300 V
- C15 0.5 UF 600 V
- C16 2 UF 600 V
- C17 0.01 UF 300 V
- C18 0.01 UF 300 V
- C19 0.002 UF 500 V
- C20.1 0.1 UF 600 V
- C20.2 0.1 UF 600 V
- C20.3 0.1 UF 600 V
- C21 0.01 UF 300 V
- C22 0.005 UF 300 V
- C23 40 UF 25 V
- C24 1 UF 600 V
- C25 2 UF 600 V
- C26 0.0005 UF 500 V
- C35 0.006 UF 300 V
- C36 10 UUF 500 V
- C38 5 UUF 500 V
- C39 0.006 UF 300 V
- C41 700 UUF 500 V
- C42 200 UUF 500 V
- C43 100 UUF 500 V
- C44 30 UUF 500 V
- C45 100 UUF 500 V
- C46 20 UUF 500 V
- C51 100 UUF 500 V
- C52 0.001 UF 500 V
- C53 50 UUF 600 UUF 500 V
- C54 10 UUF SEE NOTE 2

NOTES:

1-WHEN CAPACITORS C85 AND C86 ARE 60UUF,CAPACITOR C84 IS OMITTED.(OPTIONAL METHOD NOT SHOWN IN DIAGRAM.)

2-TWO CAPACITORS REPLACED BY ONE HAVING A CAPACITY EQUAL TO THE TOTAL OF THE REPLACED TWO.(OPTIONAL METHOD NOT SHOWN IN DIAGRAM.)

- C55 10 UUF 60 UUF 500 V
- C56 50 UUF SEE NOTE 2
- C57 0.006 UF 300 V
- C61 100 UUF 500 V
- C62 0.001 UF 500 V
- C63 50 UUF 60 UUF 500 V
- C64 10 UUF OR SEE NOTE 2
- C65 10 UUF 60 UUF 500 V
- C66 50 UUF SEE NOTE 2
- C67 0.006 UF 300 V
- C71 50 UUF 500 V
- C72 0.001 UF 500 V
- C73 50 UUF 60 UUF 500 V
- C74 10 UUF OR SEE NOTE 2
- C75 10 UUF 60 UUF 500 V
- C76 50 UUF OR SEE NOTE 2
- C77 0.006 UF 300 V
- C81 250 UUF 500 V
- C82 0.006 UF 300 V
- C83 0.006 UF 300 V
- C84 5 UUF 500 V (SEE NOTE 1)
- C85 50 UUF OR 60 UUF 500 V SEE NOTE 2
- C86 50 UUF OR 60 UUF 500 V SEE NOTE 2
- C87 25 UUF OR 35 UUF 500 V
- C88 10 UUF SEE NOTE 2
- C91 50 UUF 500 V
- C92 50 UUF 500 V
- C93 100 UUF 500 V
- C94 50 UUF 500 V

SWITCHES

- D1 REC ON-OFF
- D2 OUTPUT TO PHONES
- D3 ON-OFF SPEAKER
- D4 ON-OFF SQUELCH
- D5 TUNE-OPERATE

LAMP

- E1 CALL SIGNAL (NEON)

FUSE

- F1 FUSE 15 AMP

JACKS

- J1 PHONES
- J2 PHONES
- J3 FRONT PANEL JACK

APPARATUS LEGEND

LOUD SPEAKER

- LS1 LOUD SPEAKER

COILS

- L1 LIMITER CATHODE CHOKE
- L32 ANTENNA COUPLING
- L33 RF PLATE
- L34 MOD GRID
- L41 RF OSCILLATOR
- L42 OSC SHUNT FEED
- L51 1ST IF GRID
- L52 MODULATOR PLATE
- L61 2ND IF GRID
- L62 1ST IF PLATE
- L71 LIMITER GRID
- L72 2ND IF PLATE
- L81 DETECTOR INPUT
- L82 LIMITER PLATE
- L91 IF OSCILLATOR

POTENTIOMETERS

- P1 100,000 Ω
- P2 200 Ω

PLUGS

- PG1 RECEIVER PLUG
- PG2 DYNAMOTOR PLUG
- PG3 FRONT PANEL PLUG

RESISTORS

- R1 20,000 Ω 1/2 W
- R2 250,000 Ω 1/2 W
- R3 500 Ω 1/2 W
- R4 50,000 Ω 1/2 W
- R5 5,000 Ω 1/2 W
- R6 100,000 Ω 1/2 W
- R7 30,000 Ω 1 W
- R8 70,000 Ω 1/2 W
- R9 1,000 Ω 1/2 W
- R10 250,000 Ω 1/2 W
- R11 1,000,000 Ω 1/2 W
- R12 2,000 Ω 1/2 W
- R13 10,000 Ω 1/2 W
- R14 250,000 Ω 1/2 W
- R15 1,000,000 Ω 1/2 W
- R16 1,000,000 Ω 1/2 W
- R17 250,000 Ω 1/2 W
- R18 100,000 Ω 1/2 W
- R19 2,000,000 Ω 1/2 W

- R20 300 Ω 1 W
- R21 30,000 Ω 2 W
- R22 30,000 Ω 1/2 W
- R23 5,000 Ω 1/2 W
- R24 50 Ω 1/2 W
- R25 2,500 Ω 1/2 W
- R26 1,200 Ω 1/2 W
- R27 2,500 Ω 1/2 W
- R28 2,500 Ω 1/2 W
- R29 13,000 Ω 2 W
- R30 5 Ω 4 W
- R31 6,800 Ω 1 W
- R32 30,000 Ω 1/2 W
- R33 30,000 Ω 1/2 W
- R37 250,000 Ω 1/2 W
- R38 1,000 Ω 1/2 W
- R41 100,000 Ω 1/2 W
- R51 100,000 Ω 1/2 W
- R52 43,000 Ω 1/2 W
- R53 100,000 Ω 1/2 W
- R54 100,000 Ω 1/2 W
- R55 100,000 Ω 1/2 W
- R61 100,000 Ω 1/2 W
- R62 43,000 Ω 1/2 W
- R63 10,000 Ω 1/2 W
- R64 1,000 Ω 1/2 W
- R71 250,000 Ω 1/2 W
- R72 30,000 Ω 1/2 W
- R73 10,000 Ω 1/2 W
- R74 1,000 Ω 1/2 W
- R81 70,000 Ω 1/2 W
- R82 250,000 Ω 1/2 W
- R83 70,000 Ω 1/2 W
- R84 250,000 Ω 1/2 W
- R85 1,000 Ω 1/2 W
- R91 100,000 Ω 1/2 W
- R92 40,000 Ω 1/2 W
- R93 40,000 Ω 1/2 W

TRANSFORMER

- T1 OUTPUT TRANSFORMER

VACUUM TUBES

- V1 VT-112 (6AC7)
- V2 VT-112 (6AC7)
- V3 VT-94 (6J5)
- V4 VT-209 (12SG7)
- V5 VT-209 (12SG7)
- V6 VT-112 (6AC7)

Fig. 71. Radio Receiver BC-683-A

1ST A F AMP
& I F OSC
V10

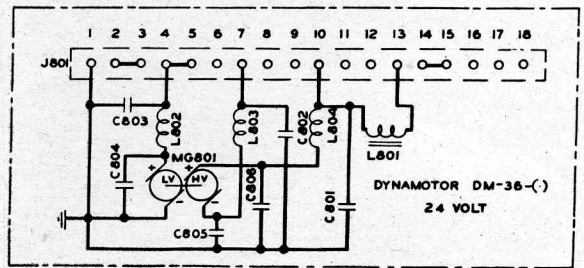
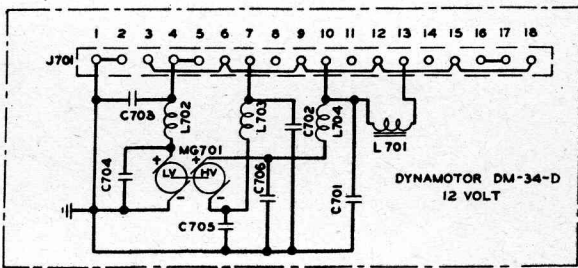
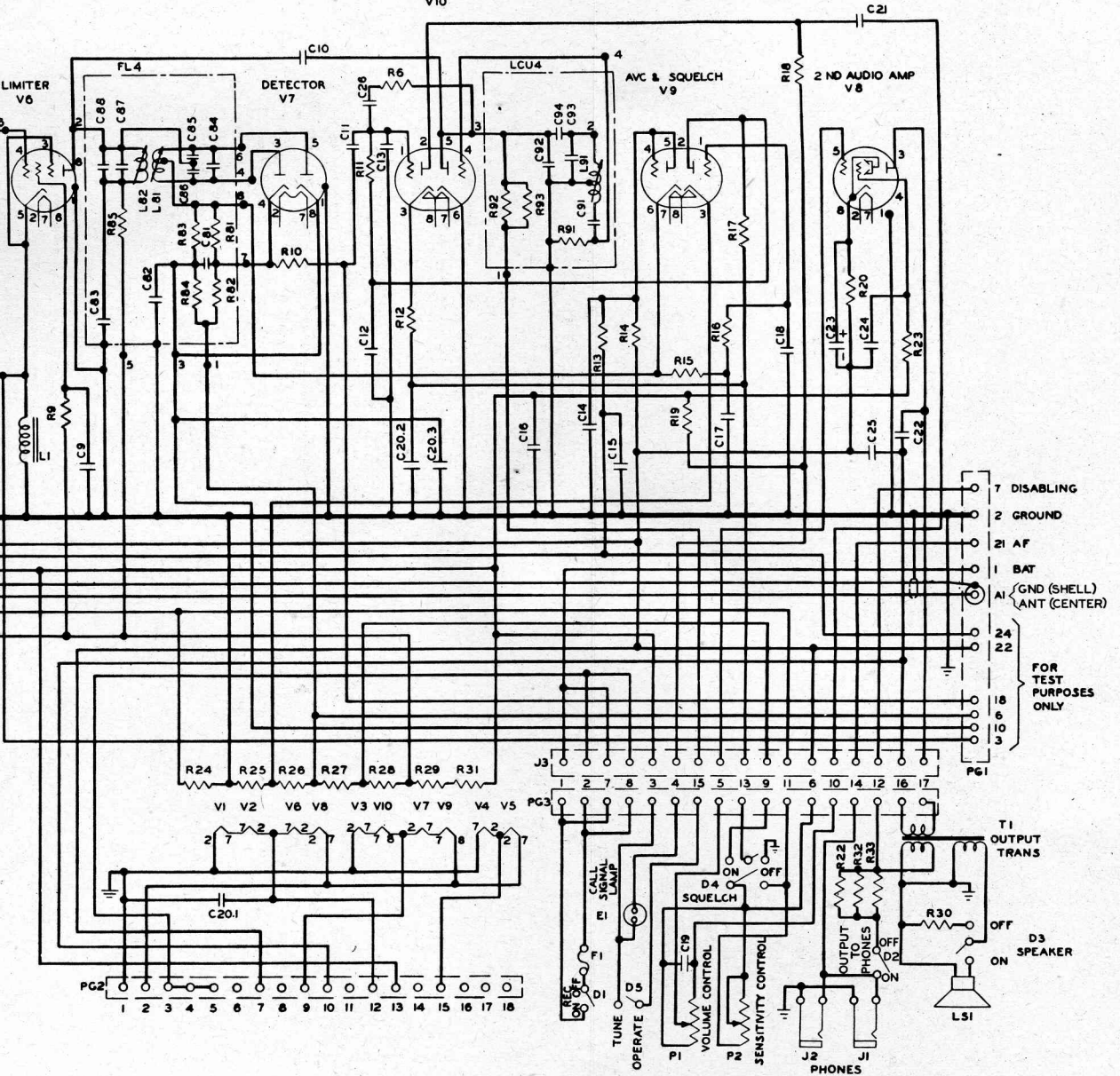

Schematic Diagram

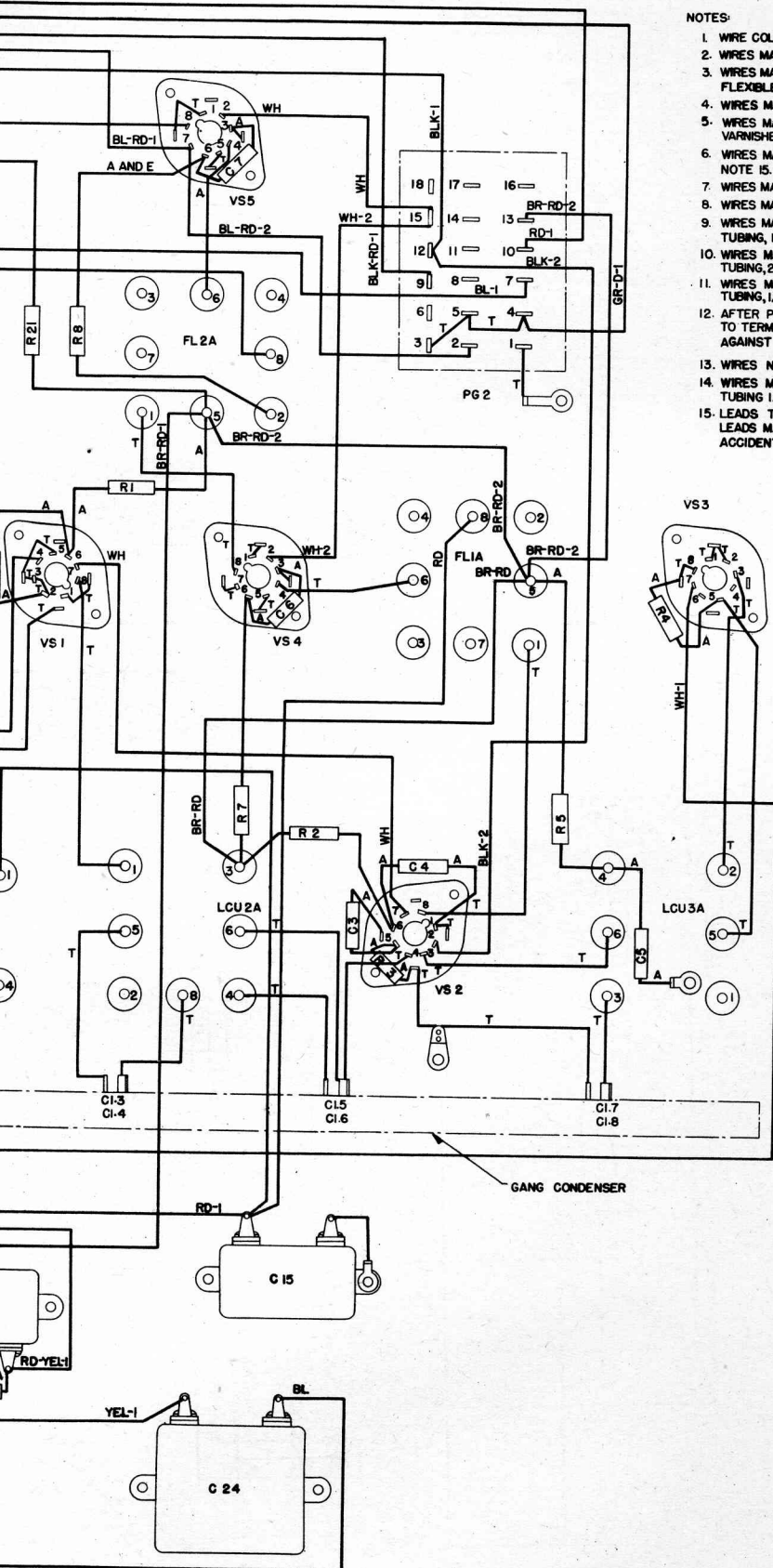

NOTES:

1. WIRE COLORS SPECIFIED ARE TRACER COLORS ON WHITE WIRE.
2. WIRES MARKED "A" ARE FURNISHED WITH APPARATUS.
3. WIRES MARKED "C" ARE NO.18 A.W.G. "T" WIRES COVERED WITH NO.18 BLACK FLEXIBLE VARNISHED TUBING.
4. WIRES MARKED "D" ARE NO.16 A.W.G. STRANDED WIRE.
5. WIRES MARKED "E" ARE "A" WIRES COVERED WITH NO.18 BLACK FLEXIBLE VARNISHED TUBING.
6. WIRES MARKED "T" ARE NO.18 OR NO.20 A.W.G. TINNED COPPER WIRE. SEE NOTE 15.
7. WIRES MARKED "1" ARE IN CABLE NO.1.
8. WIRES MARKED "2" ARE IN CABLE NO.2.
9. WIRES MARKED "G" ARE COVERED WITH YELLOW FLEXIBLE VARNISHED TUBING, 1/16 IN. LONG AT PG1.
10. WIRES MARKED "H" ARE COVERED WITH YELLOW FLEXIBLE VARNISHED TUBING, 2 IN. LONG AT PG1.
11. WIRES MARKED "L" ARE COVERED WITH YELLOW FLEXIBLE VARNISHED TUBING, 1/2 IN. LONG AT PG1.
12. AFTER PLACING YELLOW TUBING OVER LEADS AT PG1, SOLDER LEADS TO TERMINALS AND SLIP TUBING OVER SOLDERED JOINT UNTIL IT BEARS AGAINST FACE OF RECEPTACLE.
13. WIRES NOT DESIGNATED ARE NO.20 A.W.G. SOLID WIRE.
14. WIRES MARKED "M" ARE COVERED WITH YELLOW FLEXIBLE VARNISHED TUBING 1/2 IN. LONG AT PG1.
15. LEADS TO BE AS SHORT AND AS STRAIGHT AS POSSIBLE HOWEVER LEADS MAY BE FORMED WHERE NECESSARY TO INSURE AGAINST ACCIDENTAL SHORTS.

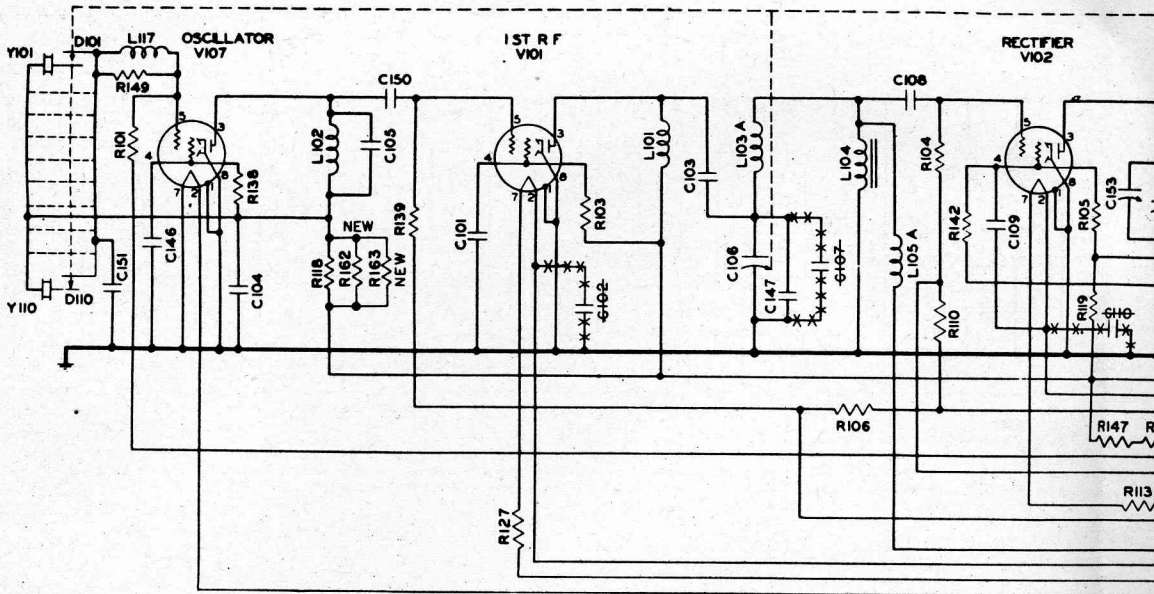

RADIO TRANSMITTER BC-684-A CAPACITORS

C101	0.003 UF 800 V
6H02	ELIMINATED IN LATER UNITS
C103	100 UUF 800 V
C104	500 UUF 800 V
C105	15 UUF 500 V
C106	350 UUF MAX-AIR GAP 0.025"
C113	60 UUF MAX-AIR GAP 0.025"
C115	60 UUF MAX-AIR GAP 0.025"
C119	80 UUF MAX-AIR GAP 0.025"
C152	60 UUF MAX-AIR GAP 0.025"
C156	60 UUF MAX-AIR GAP 0.025"
6H07	ELIMINATED IN LATER UNITS
C108	500 UUF 800 V
C109	0.003 UF 800 V
6H08	ELIMINATED IN LATER UNITS
C111	0.003 UF 800 V
C112	0.003 UF 800 V
C114	20 UUF MAX-AIR GAP 0.025"
C116	20 UUF MAX-AIR GAP 0.025"
C117	0.003 UF 800 V
C118	0.003 UF 800 V
C120	20 UUF MAX-AIR GAP 0.025"
C121	0.003 UF 800 V
C122	0.003 UF 800 V
C123	0.01 UF 300 V
C124	0.002 UF 1200 V
C125	60 UUF MAX-AIR GAP 0.030"
C126	20 UUF MAX-AIR GAP 0.025"
C127	100 UUF MAX-AIR GAP 0.0195"
C128	100 UUF MAX-AIR GAP 0.0195"
C129	100 UUF MAX-AIR GAP 0.0195"
C130	100 UUF MAX-AIR GAP 0.0195"
C131	100 UUF MAX-AIR GAP 0.0195"
C132	100 UUF MAX-AIR GAP 0.0195"
C133	100 UUF MAX-AIR GAP 0.0195"
C134	100 UUF MAX-AIR GAP 0.0195"
C135	100 UUF MAX-AIR GAP 0.0195"
C136	100 UUF MAX-AIR GAP 0.0195"
C137	0.5 UF 600 V
C138.1	0.1 UF 600 V
C138.2	0.1 UF 600 V
C139	0.5 UF 600 V
C140	30 UF 50 V
C141	0.5 UF 600 V
C142.1	0.1 UF 600 V
C142.2	0.1 UF 600 V
C143	0.5 UF 600 V
C145	2 UF 1000 V
C146	0.003 UF 800 V
C147	175 UUF 800 V
C148	0.003 UF 800 V
C149	0.001 UF 1200 V
C150	0.001 UF 800 V
C151	50 UUF 800 V
C153	20 UUF MAX-AIR GAP 0.025"
C154	0.003 UF 800 V
C155	0.003 UF 800 V
C157	20 UUF MAX-AIR GAP 0.025"
C158	0.003 UF 800 V
C159	0.01 UF 300 V
6H09	ELIMINATED IN LATER UNITS

APPARATUS LEGEND

C161	100 UUF 800 V
C162	4 UF 50 V
C164	0.003 MF 800 V (ADDED)
SWITCHES	
D101	PUSH BUTTON ASSEMBLY
TO	CRYSTAL SELECTORS
D110,	
D111	PUSH BUTTON ASSEMBLY
TO	ANT CAP SELECTORS
D120	ANT CUR-TUNE
D121	RECEIVER TUNE - OPERATE
D122	ON-OFF POWER SUPPLY
D124	METER SWITCH
D125	
LAMP	
E101	PILOT LAMP
FUSE	
F101	+ 1/2 AMPERE FUSE
JACKS	
J101	MAGNETIC MICROPHONE
J102	CARBON MICROPHONE
COILS	
L101	1ST RF PLATE CHOKE
L102	OSC PLATE
L103A	1ST RF PLATE TUNING
L104	MODULATION
L105A	RF CHOKE
L106	TRIPLER PLATE TUNING
L107	DOUBLER GRID TUNING
L108	DOUBLER PLATE TUNING
L110	POWER AMP TUNING
L111	ANTENNA COUPLING
L117	OSC GRID FILTER
L118	TRIPLER GRID TUNING
L119	RECTIFIER PLATE TUNING
L120	POWER AMP RF CHOKE
L121	POWER AMP RF GRID CHOKE
L122	POWER AMP ANTI-SING
L123	FILAMENT CHOKE (ADDED)
METER	
M101	ANT CUR-TUNE METER
POTENTIOMETER	
P101	50,000 Ω SIDETONE CONTROL
PLUGS	
PG 101	TRANSMITTER
PG 103	DYNAMOTOR
PG 104	DYNAMOTOR
RESISTORS	
R101	100,000 Ω 1/2 W
R102	667 Ω 25 W
R103	250,000 Ω 1 W
R104	70,000 Ω 1/2 W
R105	50,000 Ω 1/2 W
R106	1000 Ω 100 Ω 1/2 W
R107	30,000 Ω 1/2 W
R108	30 Ω 1/2 W
R109	75,000 Ω 2 W
R110	1,000 Ω 1/2 W
R111	30,000 Ω 1 W
R112	10 Ω 1/2 W
R113	1.0 Ω 10 W
R114	30,000 Ω 2 W
R115	100,000 Ω 1/2 W
R116	30,000 Ω 2 W
R117	50,000 Ω 1/2 W
R118	100,000 Ω 2 W
R119	1,200 Ω 1/2 W
R120	200 Ω 1 W
R121	100 Ω 1/2 W
R122	250,000 Ω 1 W
R123	10,000 Ω 1 W
R124	10,000 Ω 1/2 W
R125	5,000 Ω 1/2 W
R126	75,000 Ω 2 W
R127	1.0 Ω 10 W
R128	10,000 Ω 1/2 W
R129	5,000 Ω 25 W
R130	100 Ω 10 W
R131	12 Ω 25 W
R132	12 Ω 25 W
R133	80 Ω 10 W
R134	30,000 Ω 1/2 W
R135	30 Ω 10 W
R136	30,000 Ω 1/2 W
R137	100 Ω 1/2 W
R138	50,000 Ω 1/2 W
R139	100,000 Ω 1/2 W
R140	12 Ω 25 W
R141	12 Ω 25 W
R142	180,000 Ω 1 W
R143	100 Ω 1/2 W
R144	100,000 Ω 1/2 W
R145	50,000 Ω 2 W
R147	667 Ω 25 W
R149	50 Ω 1/2 W
R151	100,000 Ω 1 W
R153	8.3 Ω 17.9 W
R154	8.3 Ω 17.9 W
R155	100,000 Ω 1/2 W
R156	30 Ω 1 W
R157	300 Ω 1 W
R158	50 Ω 1/2 W
R159	100,000 Ω 1 W (ADDED)
R160	667 Ω 25 W (ADDED)
R161	30,000 Ω 1 W (ADDED)
R162	100,000 Ω 2 W (ADDED)
R163	100,000 Ω 2 W (ADDED)
RELAYS	
S101	ANTENNA SWITCHING
S102	DYNAMOTOR STARTING
S103	RECEIVER DISABLING

Fig. 73

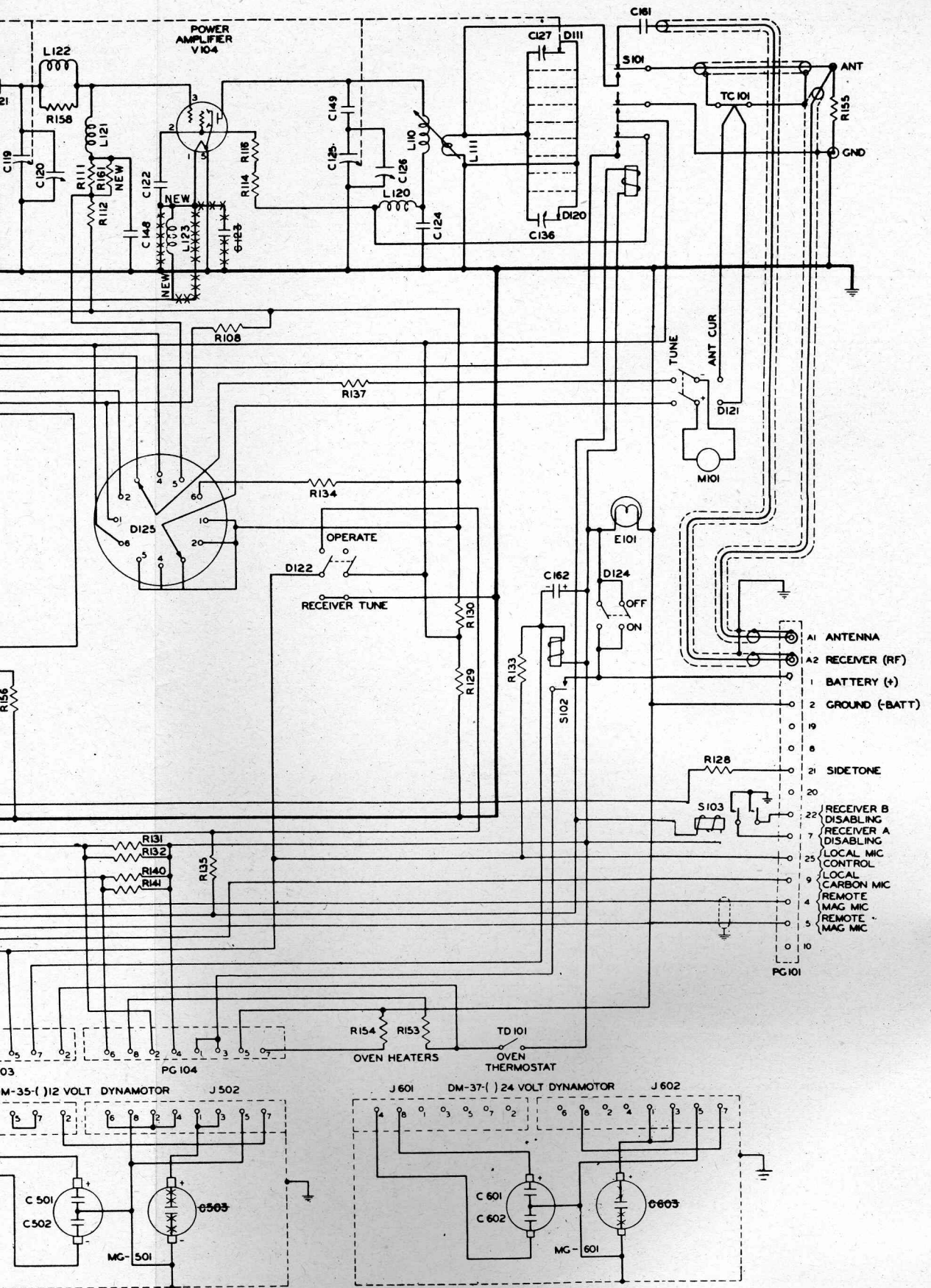

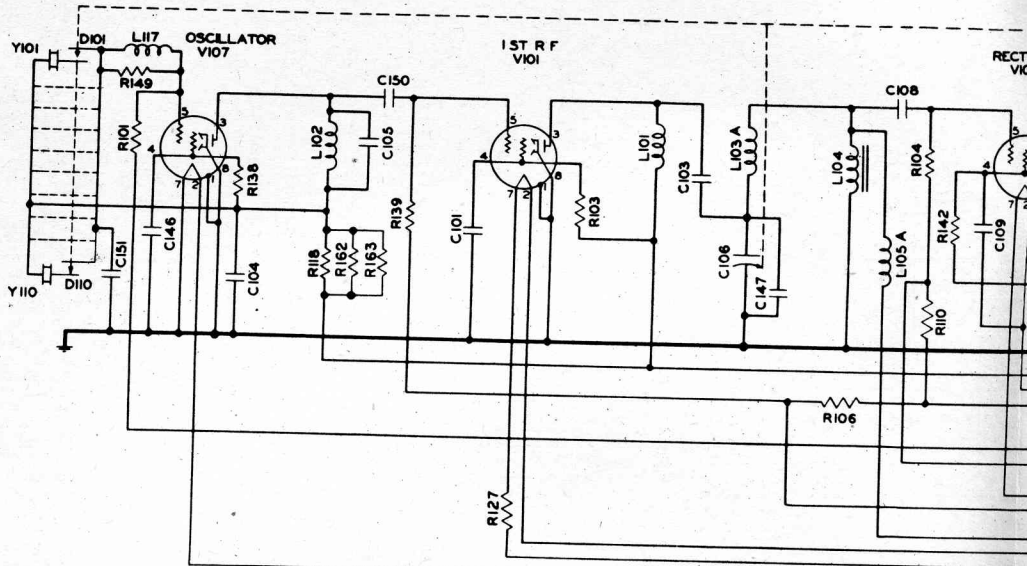

RADIO TRANSMITTER BC-684-A

CAPACITORS

C101	0,003 UF 800 V
C103	100 UUF 800 V
C104	500 UUF 800 V
C105	15 UUF 500 V
C106	350 UUF MAX-AIR GAP 0,025"
C113	60 UUF MAX-AIR GAP 0,025"
C115	60 UUF MAX-AIR GAP 0,025"
C119	80 UUF MAX-AIR GAP 0,025"
C152	60 UUF MAX-AIR GAP 0,025"
C156	60 UUF MAX-AIR GAP 0,025"
C108	500 UUF 800-V
C109	0,003 UF 800 V
C111	0,003 UF 800 V
C112	0,003 UF 800 V
C114	20 UUF MAX-AIR GAP 0,025"
C116	20 UUF MAX-AIR GAP 0,025"
C117	0,003 UF 800 V
C118	0,003 UF 800 V
C120	20 UUF MAX-AIR GAP 0,025"
C121	0,003 UF 800 V
C122	0,003 UF 800 V
C123	0,01 UF 300 V
C124	0,002 UF 1200 V
C125	60 UUF MAX-AIR GAP 0,030"
C126	20 UUF MAX-AIR GAP 0,025"
C127	100 UUF MAX-AIR GAP 0,0195"
C128	100 UUF MAX-AIR GAP 0,0195"
C129	100 UUF MAX-AIR GAP 0,0195"
C130	100 UUF MAX-AIR GAP 0,0195"
C131	100 UUF MAX-AIR GAP 0,0195"
C132	100 UUF MAX-AIR GAP 0,0195"
C133	100 UUF MAX-AIR GAP 0,0195"
C134	100 UUF MAX-AIR GAP 0,0195"
C135	100 UUF MAX-AIR GAP 0,0195"
C136	100 UUF MAX-AIR GAP 0,0195"
C137	0,5 UF 600 V
C138.1	0,1 UF 600 V
C138.2	0,1 UF 600 V
C139	0,5 UF 600 V
C140	30 UF 50 V
C141	0,5 UF 600 V
C142.1	0,1 UF 600 V
C142.2	0,1 UF 600 V
C143	0,5 UF 600 V
C145	2 UF 1000 V
C146	0,003 UF 800 V
C147	175 UUF 800 V
C148	0,003 UF 800 V
C149	0,001 UF 1200 V
C150	0,001 UF 800 V
C151	50 UUF 800 V
C153	20 UUF MAX-AIR GAP 0,025"
C154	0,003 UF 800 V
C155	0,003 UF 800 V
C157	20 UUF MAX-AIR GAP 0,025"
C158	0,003 UF 800 V
C159	0,01 UF 300 V

APPARATUS LEGEND

C161	100 UUF 800 V	R106	100 Ω 1/2 W
C162	4 UF 50 V	R107	30,000 Ω 1 W
C164	0,003 MF 800 V	R108	30 Ω 1/2 W
SWITCHES		R109	75,000 Ω 2 W
D101	PUSH BUTTON ASSEMBLY CRYSTAL SELECTORS	R110	1,000 Ω 1/2 W
D110		R111	30,000 Ω 1 W
D111		R112	10 Ω 1/2 W
D111		R113	1,0 Ω 10 W
D120	PUSH BUTTON ASSEMBLY ANT CAP SELECTORS	R114	30,000 Ω 2 W
D121		R115	100,000 Ω 1/2 W
D122		R116	30,000 Ω 2 W
D125		R117	50,000 Ω 1/2 W
D121	ANT CUR-TUNE	R118	100,000 Ω 2 W
D122	RECEIVER TUNE-OPERATE	R119	1,200 Ω 1/2 W
D124	ON-OFF POWER SUPPLY	R120	200 Ω 1 W
D125	METER SWITCH	R121	100 Ω 1/2 W
LAMP		R122	250,000 Ω 1 W
E101	PILOT LAMP	R123	10,000 Ω 1 W
FUSE		R124	10,000 Ω 1/2 W
F101	1/2 AMPERE FUSE	R125	5,000 Ω 1/2 W
JACKS		R126	75,000 Ω 2 W
J101	MAGNETIC MICROPHONE CARBON MICROPHONE	R127	1,0 Ω 10 W
J102		R128	10,000 Ω 1/2 W
COILS		R129	5,000 Ω 25 W
L101	1ST RF PLATE CHOKE	R130	100 Ω 10 W
L102	OSC PLATE	R131	12 Ω 25 W
L103A	1ST RF PLATE TUNING	R132	12 Ω 25 W
L104	MODULATION	R133	80 Ω 10 W
L105A	RF CHOKE	R134	30,000 Ω 1/2 W
L106	TRIPLER PLATE TUNING	R135	30 Ω 10 W
L107	DOUBLER GRID TUNING	R136	30,000 Ω 1/2 W
L108	DOUBLER PLATE TUNING	R137	100 Ω 1/2 W
L110	POWER AMP TUNING	R138	50,000 Ω 1/2 W
L111	ANTENNA COUPLING	R139	100,000 Ω 1/2 W
L117	OSC GRID FILTER	R140	12 Ω 25 W
L118	TRIPLER GRID TUNING	R141	12 Ω 25 W
L119	RECTIFIER PLATE TUNING	R142	180,000 Ω 1 W
L120	POWER AMP RF CHOKE	R143	100 Ω 1/2 W
L121	POWER AMP RF GRID CHOKE	R144	100,000 Ω 1/2 W
L122	POWER AMP ANTI-SING	R145	50,000 Ω 2 W
L123	FILAMENT CHOKE	R147	667 Ω 25 W
METER		R149	50 Ω 1/2 W
M10	ANT. CUR-TUNE METER	R151	100,000 Ω 1 W
POTENTIOMETER		R153	8,3 Ω 17,9 W
P101	50,000 Ω SIDETONE CONTROL	R154	8,3 Ω 17,9 W
PLUGS		R155	100,000 Ω 1/2 W
PG 101	TRANSMITTER	R156	30 Ω 1 W
PG 103	DYNAMOTOR	R157	300 Ω 1 W
PG 104	DYNAMOTOR	R158	50 Ω 1/2 W
RESISTORS		R159	100,000 Ω 1 W
R101	100,000 Ω 1/2 W	R160	667 Ω 25 W
R102	667 Ω 25 W	R161	30,000 Ω 1 W
R103	250,000 Ω 1 W	R162	100,000 Ω 2 W
R104	70,000 Ω 1/2 W	R163	100,000 Ω 2 W
R105	50,000 Ω 1/2 W	RELAYS	
		S101	ANTENNA SWITCHING
		S102	DYNAMOTOR STARTING
		S103	RECEIVER DISABLING

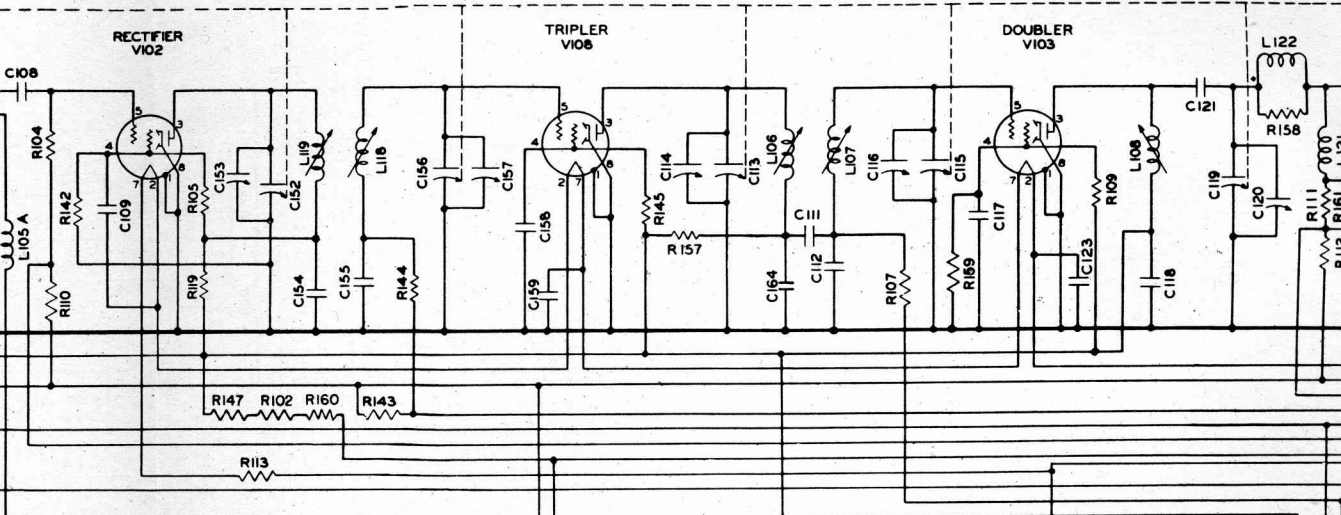

- 100 \sim 1/2 W
- 30,000 \sim 1 W
- 30 \sim 1/2 W
- 75,000 \sim 2 W
- 1,000 \sim 1/2 W
- 30,000 \sim 1 W
- 10 \sim 1/2 W
- 1.0 \sim 10 W
- 30,000 \sim 2 W
- 100,000 \sim 1/2 W
- 30,000 \sim 2 W
- 50,000 \sim 1/2 W
- 100,000 \sim 2 W
- 1,200 \sim 1/2 W
- 200 \sim 1 W
- 100 \sim 1/2 W
- 250,000 \sim 1 W
- 10,000 \sim 1 W
- 10,000 \sim 1/2 W
- 5,000 \sim 1/2 W
- 75,000 \sim 2 W
- 1.0 \sim 10 W
- 10,000 \sim 1/2 W
- 5,000 \sim 25 W
- 100 \sim 10 W
- 12 \sim 25 W
- 12 \sim 25 W
- 80 \sim 10 W
- 30,000 \sim 1/2 W
- 30 \sim 10 W
- 30,000 \sim 1/2 W
- 100 \sim 1/2 W
- 50,000 \sim 1/2 W
- 100,000 \sim 1/2 W
- 12 \sim 25 W
- 12 \sim 25 W
- 180,000 \sim 1 W
- 100 \sim 1/2 W
- 100,000 \sim 1/2 W
- 50,000 \sim 2 W
- 667 \sim 25 W
- 50 \sim 1/2 W
- 100,000 \sim 1 W
- 8.3 \sim 17.9 W
- 8.3 \sim 17.9 W
- 100,000 \sim 1/2 W
- 30 \sim 1 W
- 300 \sim 1 W
- 50 \sim 1/2 W
- 100,000 \sim 1 W
- 667 \sim 25 W
- 30,000 \sim 1 W
- 100,000 \sim 2 W
- 100,000 \sim 2 W

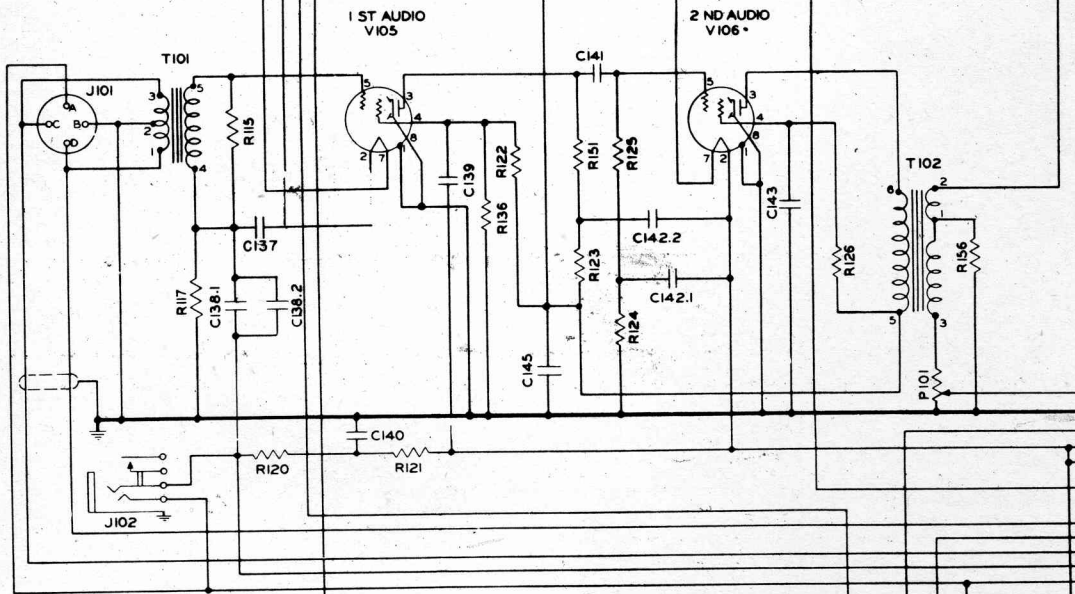

- TRANSFORMERS**
- T 101 AF INPUT
 - T 102 AF OUTPUT
- THERMOCOUPLE**
- TC 101 ANT CUR THERMOCOUPLE
- THERMOSTAT**
- TD 101 OVEN THERMSTAT
- VACUUM TUBES**
- V 101 VT-164 (1619)
 - V 102 VT-164 (1619)
 - V 103 VT-164 (1619)
 - V 104 VT 165 (1624)
 - V 105 VT-164 (1619)
 - V 106 VT-164 (1619)
 - V 107 VT-164 (1619)
 - V 108 VT-164 (1619)

- DYNAMOTOR DM-35-()12 V**
- CAPACITORS**
- C 501 0,003 UF 800 V
 - C 502 0,003 UF 800 V
- JACKS**
- J 501 DYNAMOTOR
 - J 502 DYNAMOTOR
- DYNAMOTOR DM-37-()24 V**
- CAPACITORS**
- C 601 0,003 UF 800 V
 - C 602 0,003 UF 800 V

- CRYSTAL HOLDERS**
- Y 101 } CRYSTAL HOLDERS
 - TO } FT-241-D
 - Y 110 }

- JACKS**
- J 601 DYNAMOTOR
 - J 602 DYNAMOTOR

ANTENNA SWITCHING
DYNAMOTOR STARTING
RECEIVER DISABLING

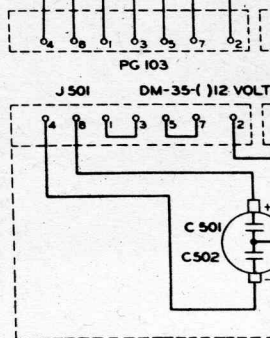
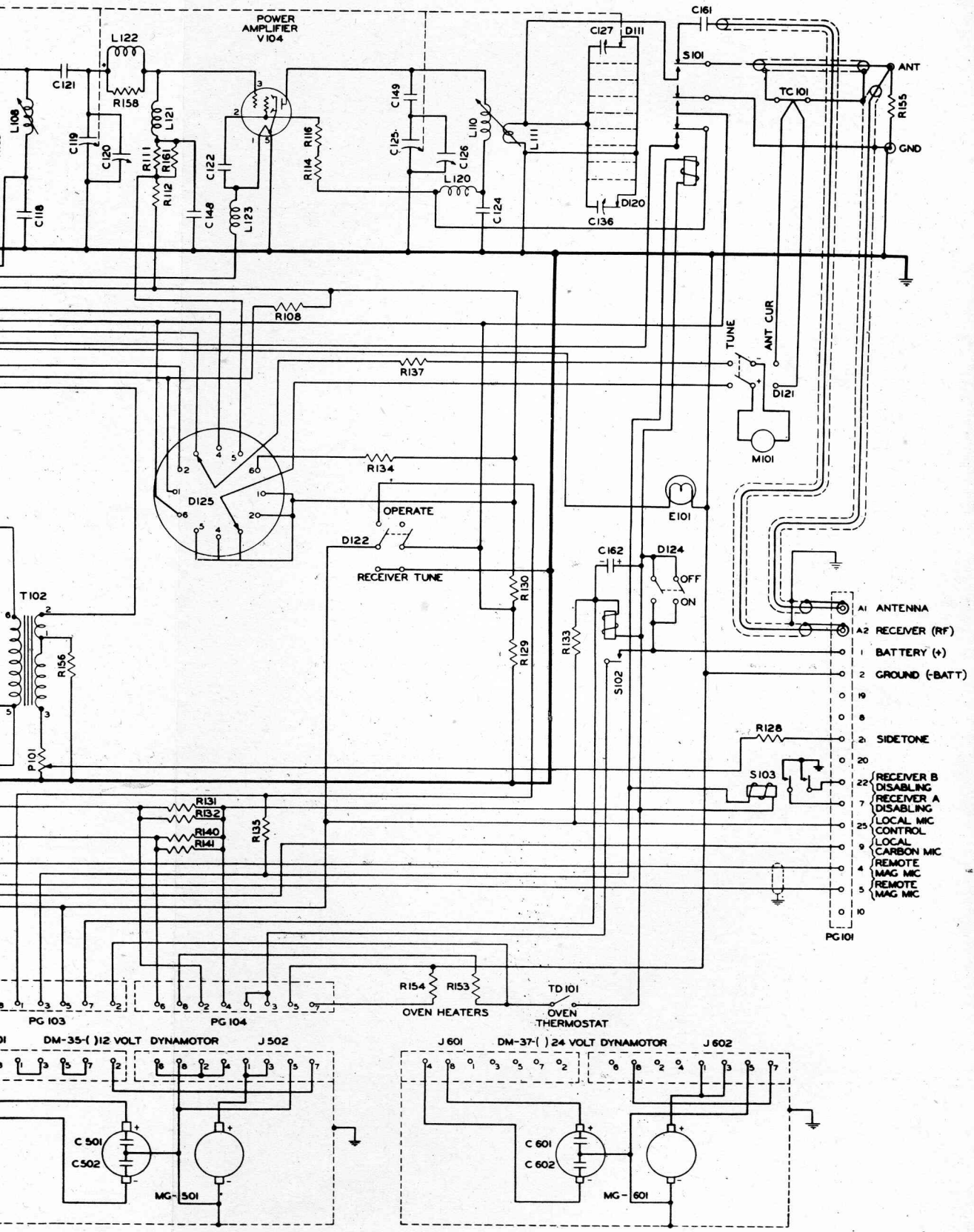
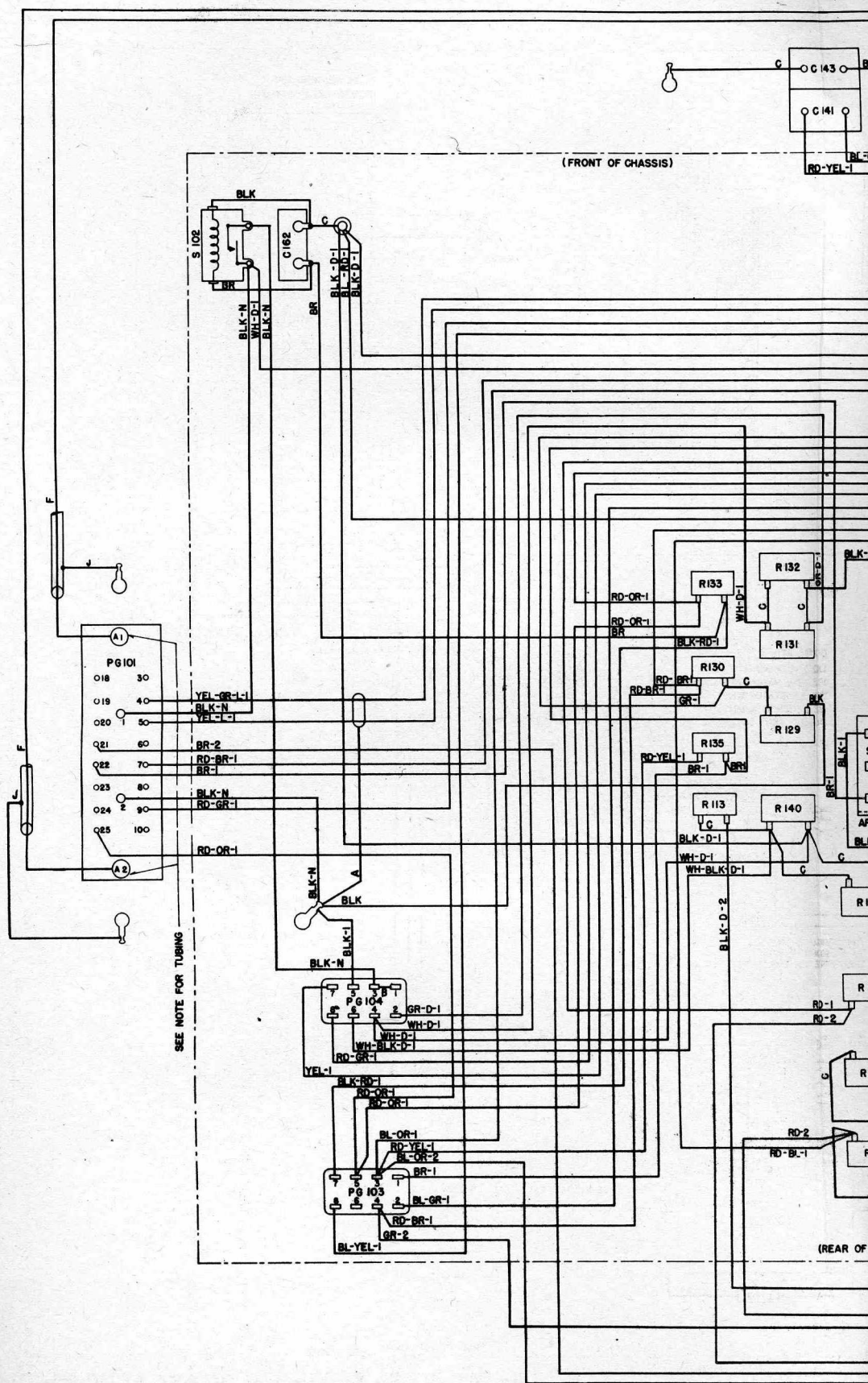

Fig. 74. Radio Transmitter BC-684-A: Schematic Diagram



- A1 ANTENNA
 - A2 RECEIVER (RF)
 - BATTERY (+)
 - 2 GROUND (-BATT)
 - 19
 - 8
 - 2 SIDETONE
 - 20
 - 22 RECEIVER B DISABLING
 - 7 RECEIVER A DISABLING
 - 25 LOCAL MIC CONTROL
 - 9 CARBON MIC
 - 4 REMOTE MAG MIC
 - 5 REMOTE MAG MIC
 - 10
- PG 101



SEE NOTE FOR TUBING

(FRONT OF CHASSIS)

(REAR OF CHASSIS)

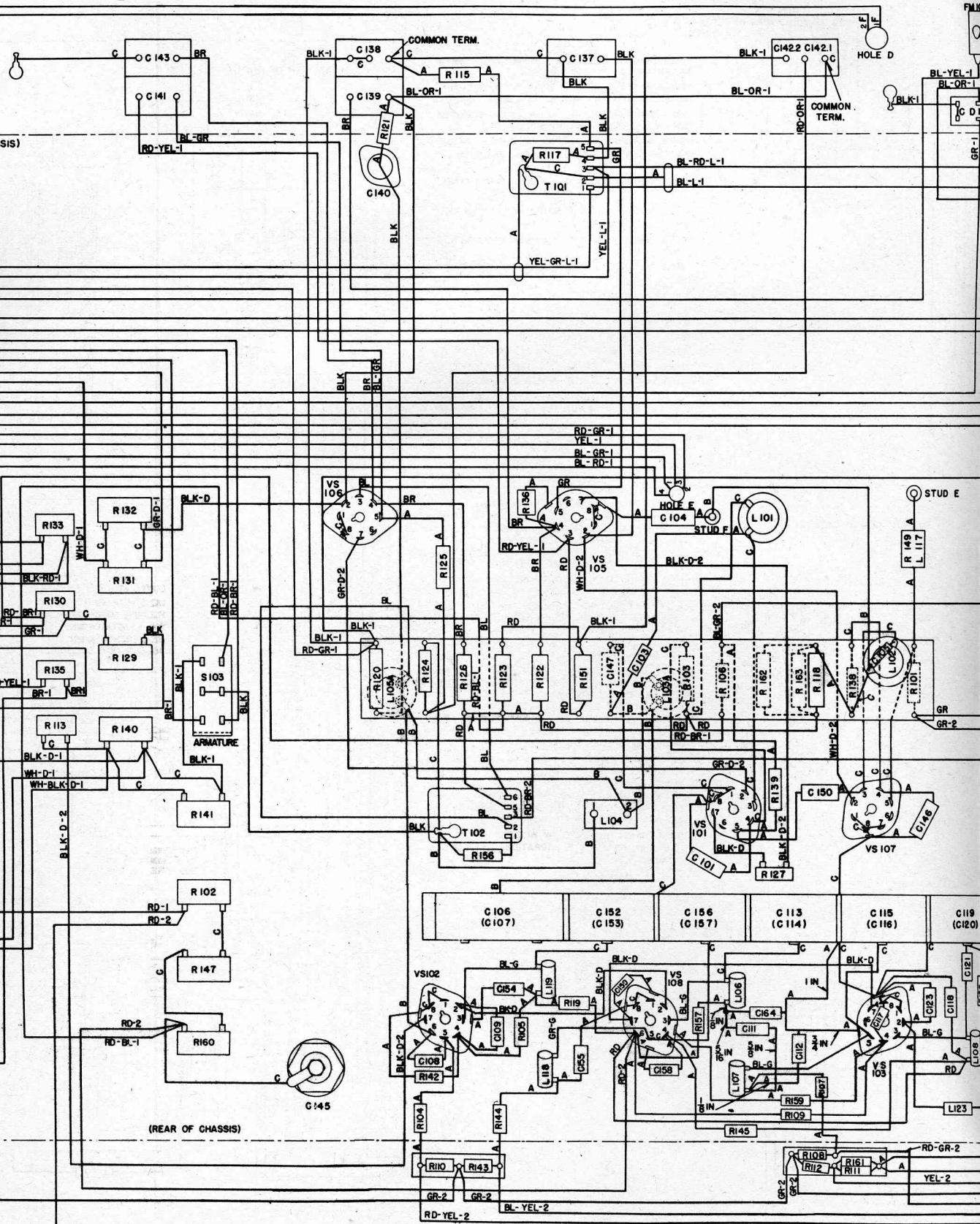
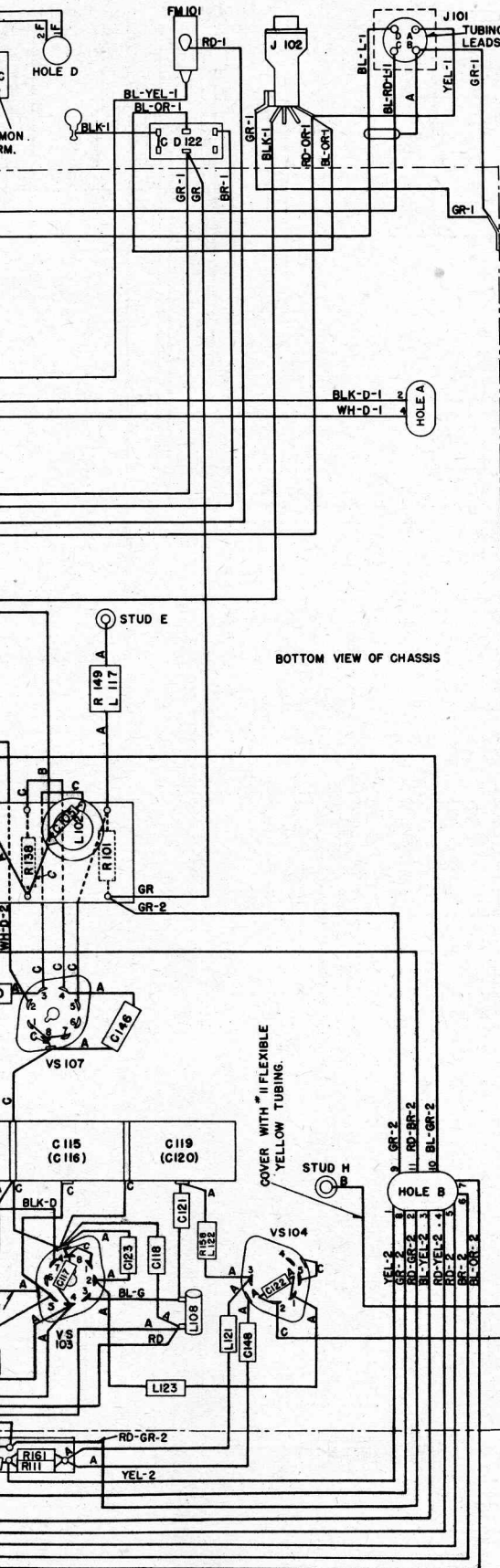

Fig. 75. Radio Transmitter BC-684-



TUBING ON THESE LEADS SEE NOTES

NOTES

1. WIRES MARKED "A" ARE FURNISHED WITH APPARATUS.
2. WIRES MARKED "B" ARE NO. 16 A.W.G.A. TINNED.
3. WIRES MARKED "C" ARE NO. 18 A.W.G.A. TINNED.
4. WIRES MARKED "D" ARE NO. 16 A.W.G.A. STRANDED 1250 VOLT RADIO HOOK-UP WIRE.
5. WIRES MARKED "E" ARE NO. 20 A.W.G.A. SOLID 1250 VOLT RADIO HOOK-UP WIRE SHIELDED.
6. WIRES MARKED "F" ARE TRANSMISSION LINE.
7. WIRES MARKED "G" ARE NO. 20 A.W.G.A. STRANDED 1250 VOLT RADIO HOOK-UP WIRE.
8. WIRES MARKED "H" ARE FLEXIBLE 1/4 IN. COPPER STRIP.
9. WIRES MARKED "J" ARE TINNED COPPER BRAID 1/4 IN. WIDE.
10. WIRES MARKED "L" ARE NO. 22 A.W.G.A.
11. WIRES MARKED "N" ARE NO. 10 A.W.G.A. STRANDED 1250 VOLT RADIO HOOK-UP WIRE.
12. WIRES MARKED "P" ARE NO. 22 A.W.G.A. T WIRE.
13. WIRES MARKED "I" ARE IN CABLE NO. 1.
14. WIRES MARKED "2" ARE IN CABLE NO. 2.
15. ALL OTHER WIRES NOT MARKED ARE NO. 20 A.W.G.A. SOLID 1250 VOLT AEROGLOSS RADIO HOOK-UP WIRE.
16. ALL WIRE IS WHITE BACKGROUND. COLORS SPECIFIED ARE TRACER COLORS.
17. AT PG101 AND J101 PLACE A 7/8 INCH LENGTH OF YELLOW FLEXIBLE VARNISHED CAMBRIC TUBING OVER WIRE, SOLDER WIRE TO TERMINAL, AND SLIP THE TUBING OVER SOLDERED JOINT UNTIL IT BEARS AGAINST BACK FACE OF JACK OR RECEPTACLE. USE NO. 11 TUBING FOR SMALL WIRES AND NO. 4 TUBING FOR LARGE WIRES OR WHERE TWO WIRES ARE CONNECTED TO THE SAME TERMINAL.
18. WHERE 3 OR MORE WIRES WHICH ARE NOT SEWN INTO THE CABLE RUN PARALLEL THEY SHALL BE TIED TOGETHER AT APPROXIMATELY ONE INCH INTERVALS IN ORDER TO HOLD THEM NEATLY AND SECURELY IN PLACE.
19. EACH WIRE END SHALL BE WRAPPED AROUND THE TERMINAL TO WHICH IT CONNECTS FOR AT LEAST ONE FULL TURN, CRIMPED TO TERMINAL, THEN NEATLY SOLDERED; EXCEPT AT PG101 AND J101 WHERE THE WIRES MUST ENTER THE END OF THE TERMINALS FOR AT LEAST 1/8 INCH AND THEN NEATLY AND SECURELY SOLDERED. CARE SHALL BE USED TO PREVENT SOLDER FROM RUNNING INTO TUBE SOCKET PIN CLIPS.
20. BARE WIRES, EXCEPT THOSE RUNNING DIRECTLY TO A GROUND LUG, MUST CLEAR ALL ADJACENT WIRES AND APPARATUS BY AT LEAST 1/8 INCH, AND MUST BE SO FORMED AS TO PREVENT CONTACT BEING MADE DURING THE NORMAL MOVEMENT OF ANY ADJACENT ITEM OR PART.
21. INCORPORATE BENDS IN "B" WIRES TO L103A, L104 AND L105A TO RELIEVE VIBRATION STRESS ON TERMINALS.

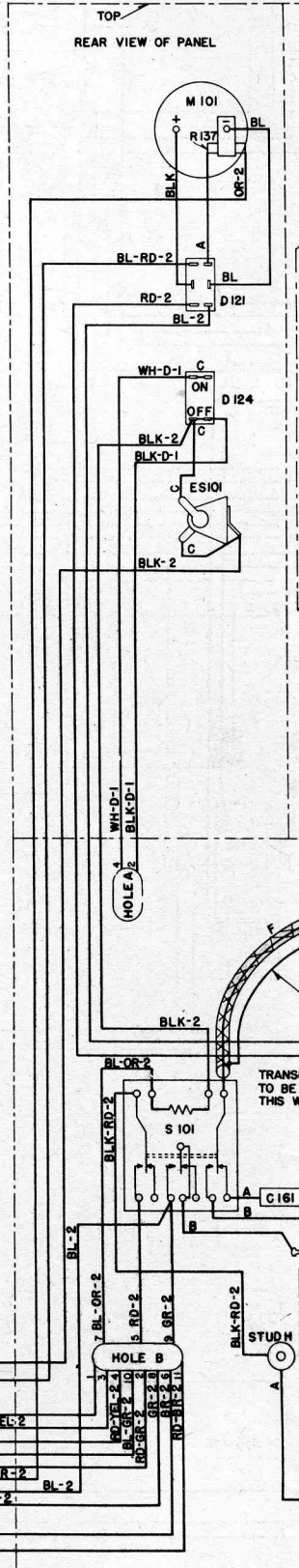

Transmitter BC-684-A: Wiring Diagram

CAUTION! REMOVE BATTERIES BEFORE STORING

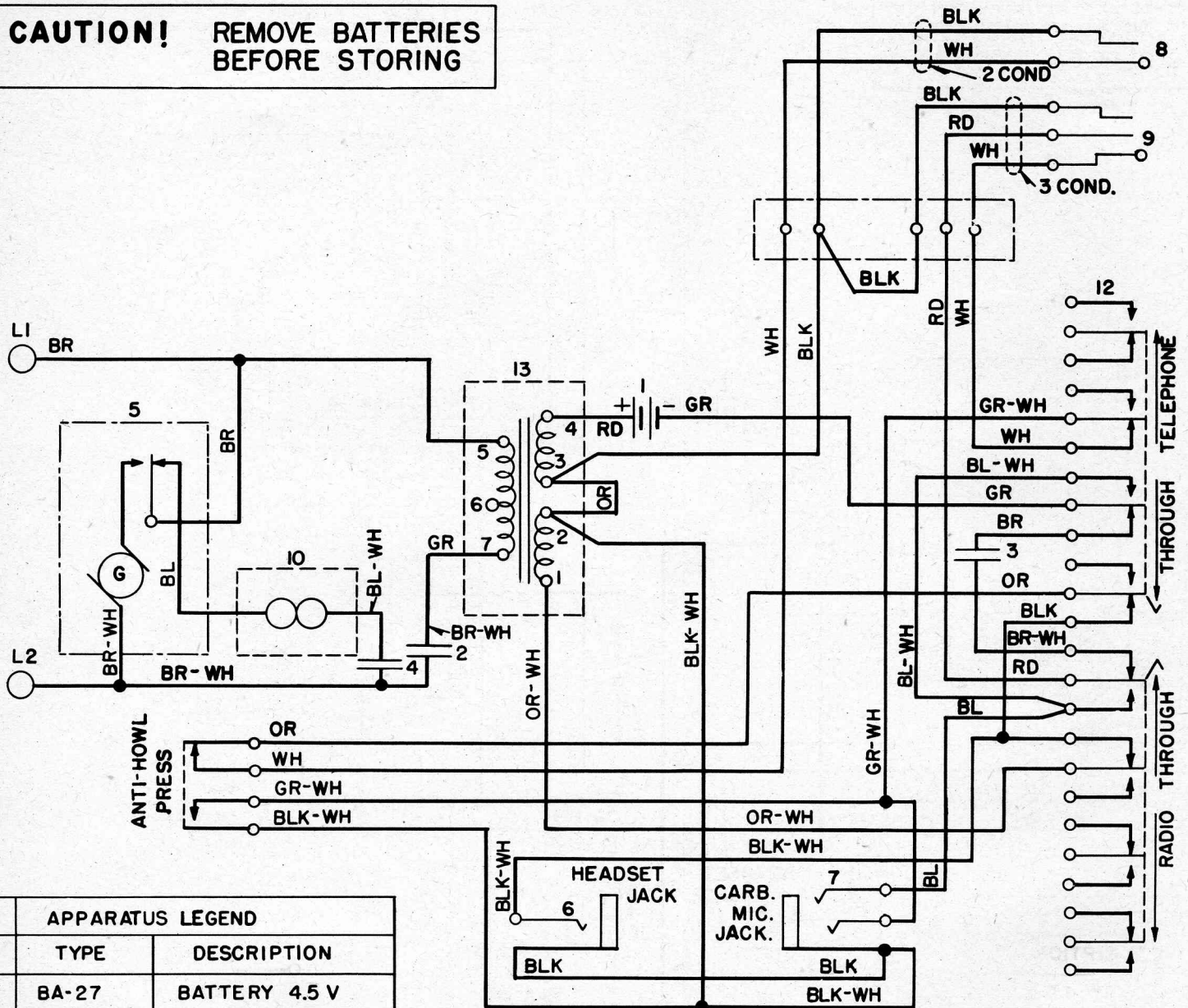

APPARATUS LEGEND		
PART	TYPE	DESCRIPTION
1	BA-27	BATTERY 4.5 V
2	CA-389	CAPACITOR
3	CA-275	CAPACITOR
4	CA-389	CAPACITOR
5	GN-38	GENERATOR
6	JK-34A	JACK
7	JK-33A	JACK
8	PL-55	PLUG
9	PL-68	PLUG
10	MC-131	RINGER
11	SW-175	SWITCH
12	SW-185	SWITCH
13	C-280	TRANSFORMER

Fig. 76. Remote Control Unit RM-29-D: Schematic and Wiring Diagram

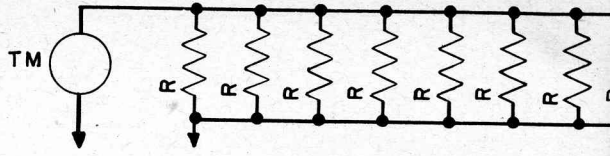

SCHEN

APPARATUS DESIG.	DE
R	15 RESISTORS, IRC F3
TM	THERMOAMMETER WI
	(BA

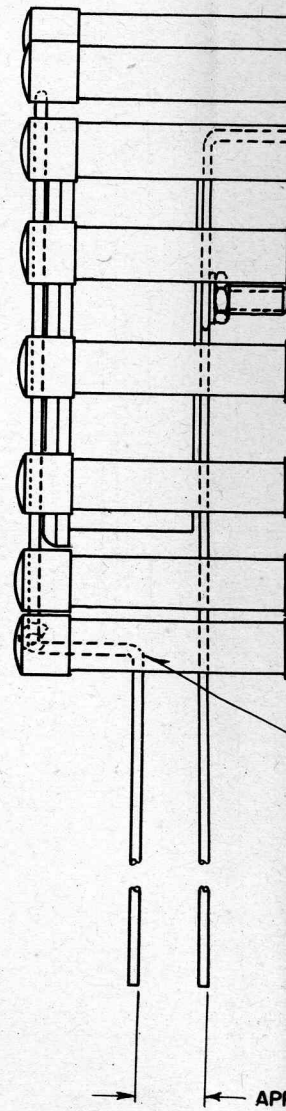
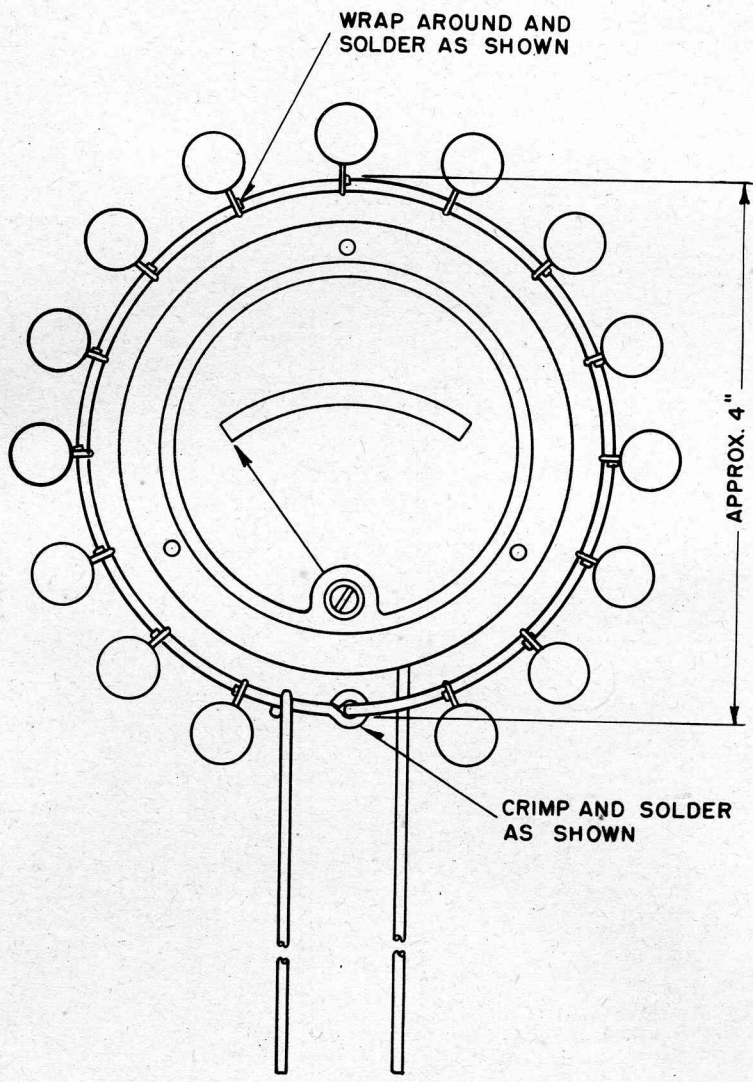

ASSEMBL

Fig. 77. Artificial Antenna for Testing Ra

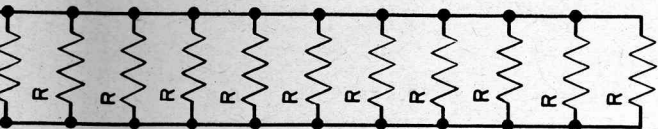

SCHEMATIC CIRCUIT DIAGRAM

DESCRIPTION
RESISTORS, IRC F3, EACH 600 OHMS (APPROX. 40 OHMS TOTAL)
DC MILLIAMMETER WESTON MODEL 425 0-1 AMP.
(BAKELITE CASE, FLUSH MOUNTING)

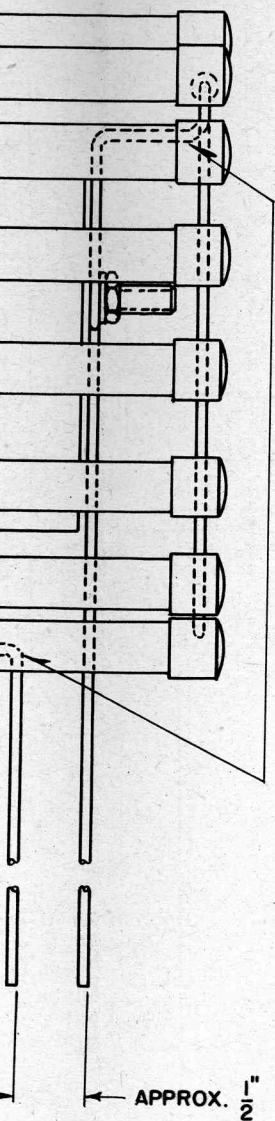

BEND LEADS
APPROX. AS SHOWN

NOTE:
RINGS AND LEADS SHALL
BE NO. 12 A.W.G. TINNED.

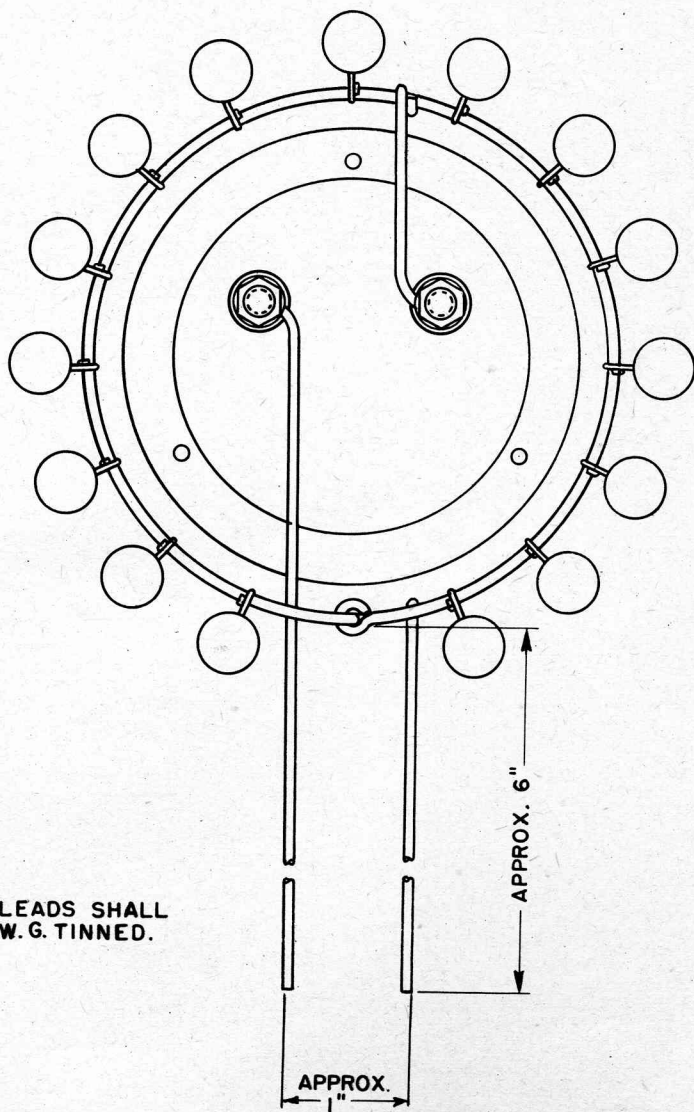

ASSEMBLY